

City of North Augusta

SEDIMENT AND EROSION CONTROL MANUAL

(A component of the NA Stormwater Management Manual – Part A)



**North
Augusta**
*South Carolina's
Riverfront*
December 2022

THE CITY OF NORTH AUGUSTA
EROSION AND SEDIMENT CONTROL MANUAL

Contents

CHAPTER 1 INTRODUCTION	5
CHAPTER 2 LAND GRADING AND SITE PREPARATION BMPs	9
SCHEDULING –Sequence of Construction	9
MINIMIZE DISTURBANCE – PHASING PROJECTS	10
Minimizing disturbance:	10
UNDISTURBED BUFFER STRIPS NEAR STREAMS AND WETLANDS	11
Natural Vegetative Buffers Required:.....	11
Topsoil preservation requirement:	11
LAND GRADING FOR MINIMIZING EROSION – AVOIDING STEEP SLOPES	12
Minimizing disturbance and creation of steep slopes	12
SURFACE ROUGHENING	15
TEMPORARY GRAVEL CONSTRUCTION ENTRANCE/EXIT	17
CHAPTER 3 VEGETATIVE ESTABLISHMENT BMPs	19
SEEDING FOR EROSION CONTROL: GENERAL SEEDING GUIDELINES	19
HYDRAULIC PLANTING	21
MULCHING	23
CHAPTER 4 STORMWATER CONVEYANCE BMPs.....	25
GRASSED-LINED CHANNELS	25
ROCK LINED CHANNEL.....	29
TEMPORARY DIVERSION DIKE.....	31
SLOPE DRAIN.....	33
WATERBARS AND ROLLING DIPS	37
ENERGY DISSIPATORS	40
CHAPTER 5 EROSION CONTROL BMPs	43
EROSION CONTROL BLANKETS AND MATS	43
RIPRAP.....	48
Check Dams	51
Cellular Confinement Systems.....	52
CHAPTER 6 SEDIMENT CONTROL BMPs	54
Temporary Sediment Traps, Excavated Sediment Traps, & Excavated Storm Drain Inlets	54
TEMPORARY SEDIMENT BASIN	56
BRUSH BARRIER	61
SILT FENCE.....	62
City of North Augusta Approved - Types of Silt Fence	63
DROP INLET SEDIMENT BARRIERS.....	72
CURB INLET SEDIMENT BARRIERS.....	75
CHAPTER 7 BANK STABILIZATION / BIOENGINEERING.....	79
STRUCTURAL STREAMBANK STABILIZATION	79
Appendix A: REFERENCES	83
Appendix B: City of North Augusta Construction Permitting & Land Disturbance Ordinance	84

(Cover photo: Failed BMPs and Flooding in North Augusta, 2021)

The primary purpose of this Manual is to present effective Best Management Practices (BMPs), which may be used during and after construction to reduce pollutant discharges to the City storm drain system, wetlands, and streams.

CHAPTER 1 INTRODUCTION

The practice of erosion and sediment control on construction sites is scrutinized from federal, state, and local governments as well as the general public. The South Carolina Department of Health and Environmental Control (SCDHEC) has had authority over permitting for construction sites conducting land disturbing activities since the mid 1990's. On July 1, 2004 the City of North Augusta Stormwater Management Department (SWMD) received delegation of the stormwater program from SCDHEC. Since then, the North Augusta SWMD reviews land disturbance applications for compliance with Chapter 14, Article V, Division 3 of the North Augusta Code of Ordinances entitled Construction Permitting for Land Disturbing Activities. This document is part of the North Augusta Stormwater Management Plan (also referred to as the North Augusta Stormwater Management Manual).

A land disturbance/development project review is initiated upon submittal of a complete stormwater application for compliance with the latest requirements of regulations by city, state, or federal agencies. The application is reviewed for compliance with the currently active SCDHEC NPDES Construction General Permit SCR100000. Therefore, as federal and state permit requirements change, items in this manual may be changed to reflect that with additional information or removals as necessary.

This manual is only a guidance document to assist you in the selection of appropriate Best Management Practice (BMP) for erosion and sediment control. Other guidance documents including ones from SCDHEC, SC Department of Transportation (SCDOT), and other agencies that may be helpful to you. Also, since this field is rapidly changing, the presence or absence of any BMP, or specifications for any BMP in this document is subject to revision as additional information becomes available. Verify that you have the latest version of this document (date at bottom left of each page).

For information about water quality requirements and water quality BMPs, please download Part B of the SWMP Manual, the North Augusta Water Quality Manual (NA-WQM) at www.northaugustasc.gov or you may pick up a hard copy at the North Augusta Municipal Center – Stormwater Management office. The NA-WQM is the city's design guide to meet the water quality requirements (prior to release, the 1st one inch of stormwater must be treated). The manual gives guidance on BMPs to implement during construction and post-construction.

Discussion:

Unlike engineering standards, many BMPs do not have uniform specifications, quantifiable effluent limits, nor do they have predictable effectiveness. **BMPs do however require design.** The designer must have an understanding of the BMP design considerations, installation techniques, construction specifications and maintenance requirements in order to design erosion control practices that "fit the site" and are thereby effective in reducing erosion and sedimentation.

Site plans are to be developed to achieve an 80 percent design removal efficiency of total suspended solids (TSS) goal. Simply applied, when a site is completely denuded of vegetation, the structural and nonstructural erosion and sediment control measures are designed to trap 80 percent of the TSS that are generated by the site. The design storm event associated with this level of control is the **10-year 24-hour SCS Type II storm** event.

SCS procedures should be used to determine runoff amounts. It is important to note that when a BMP is designed for the 10-year 24-hour storm event, the BMP will have a greater trapping efficiency for more frequent events such as the 2-year 24-hour storm event.

One problem on too many construction sites is that when one BMP fails, it is simply re-installed as it was before. How many of us have seen the same section of silt fence be resurrected again and again with no more hope for success than it had in the beginning? **BMPs are 'performance-based' construction standards.** They require constant monitoring and evaluation. **If they don't work, adapt them or move up to the next level of BMP protection.** Many BMP's originated over 35 years ago and time has proven that some are not effective and have fallen into disuse. These and other BMPs, which have also proven to be marginally effective, are still widely used today. Contractors may be comfortable installing them and the designers may have become complacent, often designing the erosion control as an after-thought to the "real" project work.

Take silt fence, for example. Silt fence is one of the most widely used BMPs for non-point source pollution protection. However, from a practical stand point, it is probably the least effective measure in use across the nation. Typical silt fence installation renders it ineffective. The fences are not trenched and compacted. Improper application of silt fence frequently results in increased erosion. The optimum method of silt fence installation is via the *slicing* method where a pull behind machine makes a narrow cut into the soil leaving the surrounding soil undisturbed and stronger. At a minimum trenching is required. Please review the section on silt fence for more information and guidance.



APPLICATIONS OF EROSION AND SEDIMENT CONTROL PRACTICES

Frequently, the wrong BMP is implemented for the type of control needed. A sediment control BMP should not be used for erosion control and an erosion control BMP should not be used when runoff control is needed. When the needed control is treated with the wrong type of BMP, failure usually occurs.

For example, a silt fence is placed across a slope to prevent erosion. Maybe the designer wanted to stop sheet and rill erosion. In actual practice the silt fence collected and concentrated water, which was diverted to a low spot where the fence becomes overloaded and fails. An Erosion Control BMP should have been chosen to treat the erosion problem. Silt fences are intended for sediment control and should, therefore, be installed in relatively flat areas suitable for ponding water and depositing sediment.

A good way to avoid confusion when choosing BMPs is to have a clear understanding of what type control is needed and what the corresponding BMPs are. There are three general categories of controls that have distinct treatments associated with them; **1) erosion control, 2) runoff control, and 3) sediment control.**

Water Quality Impacts Due to Erosion and Sedimentation

Water quality may be impacted during construction activities by sediment runoff from erosion of the site and pollutants from materials stored or used on site during construction. Post construction water quality impacts are due to the runoff of silt, fertilizers, pesticides, fuels, antifreeze, metals, and other pollutants. Impervious areas facilitate the transport of pollutants into aquatic environments.

During construction, disturbing the land reduces a site's natural resistance to erosion by removing the vegetative ground cover, exposing the soil, and changing the topography. The severity of erosion depends on the type of soil, the amount and intensity of rainfall, length and gradient of slopes, and surface cover.

Water quality effects due to construction site runoff include:

- Sediment deposition in the storm drainage system; clogs pipes and inlets causing inlet bypassing and erosion and results in increased maintenance costs.
- Impacts to aquatic organisms due to an increase in turbidity. Turbid water interferes with respiration and filter feeding behavior of macroinvertebrates as well as reduces fish feeding success due to visual impairment. Turbidity decreases photosynthesis for primary producers. Sediment deposition fills pools and interstitial spaces in the stream bottom necessary for macroinvertebrates and juvenile fishes. Sedimentation of shallow areas chokes out aquatic vegetation and can completely fill the stream bed.
- Many pollutants, especially metals, are bound to and transported with sediments.
- Stream paths may be altered by excessive sedimentation.
- Sedimentation of wetlands reduces their ability to filter runoff and recharge groundwater.

The primary purpose of this Manual is to present effective Best Management Practices (BMPs), which may be used during and after construction to reduce pollutant discharges to the City storm drain system, wetlands, and streams.

EROSION AND SEDIMENT CONTROL PLANS

C-SWPPP: The erosion control plan or stormwater pollution prevention plan (SWPPP) must be prepared before construction begins, ideally during the project planning and design phases. A comprehensive SWPPP (C-SWPPP) is the full plan with all required documentation and drawings (including calculations).

OS-SWPPP: An on-site SWPPP (OS-SWPPP) is the C-SWPPP minus the calculations. The erosion control plan is submitted along with the rest of the project package during engineering and planning Departmental review. The Stormwater Management Department will review the C-SWPPP as other City Departments review other aspects of the project. This applies to commercial development, redevelopment and residential subdivision infrastructure projects.

For individual lot residential construction, a smaller brochure (BMP guide) is provided at the time of building permit issuance from Building Standards Department. The guide details BMPs for individual house construction on single lots within subdivisions or not.

For all projects, sediment and erosion control BMPs shall be installed upon initial clearing. Once BMPs are installed, the Stormwater Management Department is to conduct an inspection. No additional building inspections are conducted without a satisfactory initial BMP inspection.

If the site or portion of the site is idle for more than 14 days, then vegetative stabilization must be accomplished within seven days. A wet weather plan should include a plan for the immediate installation of emergency erosion control measures (within 24 hours of the first forecast of a storm front).

FOLLOW THE PLAN: It is important to install the BMPs designed in the sediment and erosion control plan according to the design engineers **approved** set of plans. Just as important, is that the site contractor must insure that they are **inspected, repaired and maintained** so that they are always able work as they were designed. For all sites, if the site contractor or site inspector determine that the BMPs designed are not adequate to protect the environment, additional BMPs can be installed as long as they are minor modifications to the site plan and do not disturb additional acreage. In all cases of minor modifications, the site contractor or site engineer must indicate the changes made (write them down) on the approved site plan at the site, date the change, and initial that the change was made and why. The modification log within the OS-SWPPP should also be filled in noting the change.

CHAPTER 2 LAND GRADING AND SITE PREPARATION BMPs

Soil is most vulnerable during site preparation as the vegetation is removed and soil is disturbed loosening bonds, which help undisturbed soil to resist erosion. The types of BMPs chosen at this early stage form the foundation of a successful erosion and sediment control plan.

SCHEDULING –Sequence of Construction

Definition: Construction Sequence (BMP) required.

Sequencing the construction project to reduce the amount and duration of soil exposed to erosion by wind, rain, runoff, and vehicle tracking is an effective BMP. The construction sequence is a schedule giving the contractor an orderly listing of all major land-disturbing activities to occur together with the necessary erosion and sedimentation control measures planned for each project. This type of schedule guides the contractor on work to be completed, before other work is started so that serious erosion and sedimentation problems can be avoided. **This BMP must be considered on all projects** to avoid impacts and **is required**. For projects over five acres (5 acres), it is one of the key BMPs designed to prevent offsite impacts.

Purpose:

Following a specified work schedule (that coordinates the timing of land-disturbing activities and the installation of control measures) is perhaps **the most cost-effective way of controlling erosion during construction**. The removal of surface ground cover leaves a site vulnerable to accelerated erosion. Construction procedures that limit land clearing or phase land clearing, provide the timely installation of erosion and sedimentation controls and restore protective cover quickly, can significantly reduce the erosion potential of a site.

Design Considerations:

Project design considerations: Design the project to integrate into existing land contours. Significant re-grading of a site will require costlier erosion and sedimentation control measures and may require installation of on-site drainage and sediment control facilities.

Incorporate existing natural areas: Inventory and evaluate the existing site terrain and vegetation. Disturbance of highly erosive natural areas (e.g., steep, unstable slope areas (<30%) and watercourses) is to be minimized, while protecting other areas may enhance site aesthetics. Construction should not disturb these areas.

Avoid rainy periods:

- Allow enough time before rainfall begins to stabilize the soil with vegetation or physical means or to install temporary sediment trapping devices.
- Apply perimeter control practices: Protect the disturbed areas from off-site runoff and prevent sedimentation damage to areas below the development site by applying perimeter control devices.

Minimize soil exposed at one time:

Schedule projects to disturb only small portions of the site at any one time (phasing construction). Complete grading as soon as possible. Immediately stabilize the disturbed portion before grading the next portion. Practice staged seeding in order to re-vegetate cut and fill slopes as the work progresses.

MINIMIZE DISTURBANCE – PHASING PROJECTS

Definition:

Minimizing disturbance is a planning process to retain natural vegetative cover and to maintain the natural infiltration at the site as much as possible, and sequencing disturbances. A **buffer strip** is the term used to describe the preservation of up to a DHEC required 30 foot (but no less than a city required 25 foot) area of undisturbed natural vegetative buffer near watercourses (rivers, streams, creeks, ponds, wetlands, etc.). The placement of BMPs may not encroach into the required buffer unless the approved site plan indicates otherwise. The last row of silt fence cannot be placed within the edge of a buffer.

Purpose:

Minimizing disturbance:

Erosion can be reduced 98% by protecting the soil from raindrop impact. Existing native vegetation usually provides the best soil protection. One of the **most effective erosion control measures** is to **only disturb areas immediately needed for construction**. Water that impacts natural vegetative cover is absorbed much more effectively due to less compaction from heavy equipment, presence of natural soils and soil stratification layers, layers of organic material and natural root systems, and groundwater recharge processes. Preservation of natural vegetation is an important tool to prevent sediment loss and erosion on construction sites and these buffers are critical to protect streams from impacts.

Bottom line, minimizing disturbance saves money by lowering the need for sediment and erosion controls throughout the site.

Phasing: City ordinance requires that sites over 20-acres must be phased. There are two types of phasing; one required for all construction sites over five (5) acres, and the other, additional phasing that is required for sites larger than 20 acres.

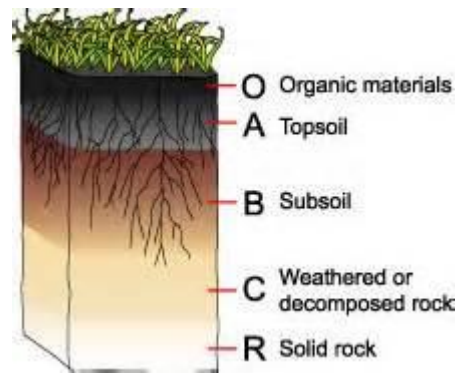

Example A: A 47-acre site is proposed for development designed to disturb 36 acres of land. The site should be phased into two project phases. This is to break up the land disturbance into two distinct project phases to meet the city ordinance with each project phase less than 20 acres of land disturbance. Each project phase will also have a sediment and erosion control plan that is phased as required by NPDES (including an Initial, Intermediate and Final SESC Plan with each having its own sequence of construction) included as separate sheets in the site plan. The first project phase would be completed to stabilization (temporary or permanent) prior to the second phase being able to start.

Example B: A 27-acre site is proposed with a disturbed area of 21.5 acres. This site could potentially be submitted as one overall phase of development where the required NPDES phasing, Initial, Intermediate and Final SESC plans will limit the disturbance to under 20 acres at any giving time being disturbed.

UNDISTURBED BUFFER STRIPS NEAR STREAMS AND WETLANDS

Natural Vegetative Buffers Required:

Buffers: 30'-45' required for SC-DHEC NPDES and 25' City of North Augusta Required

To protect water quality, prevent stream physical degradation, and to filter pollutants from streams, creeks, wetlands or other water courses, **30 feet of natural vegetation should not be disturbed as a buffer**. All BMPs should be located outside of this buffer. These vegetated buffer strips act to filter sediment and pollutants carried from the construction site by rain before they reach the watercourse. If sediment somehow bypasses or overtops BMPs, the natural vegetative buffer can help to prevent impacts to the streams or wetlands they are designed to protect. Some delegated as pristine streams or those that are already impacted, known as 303D listed streams or Total Maximum Daily Load (**TMDL**) streams (protected from further impact by regulation), require a **45' buffer strip**. Also, note that any site where land disturbance encroaches within 100' of a stream or waterbody, must provide a **wetland delineation**.

Topsoil preservation requirement:

When grading a project, topsoil is required to be preserved and stock piled until construction is complete. Replacing the subsoil layer post-construction along with the topsoil layer will approximate pre-construction drainage characteristics and soil structure. This practice is more likely to result in a healthy soil community and planting success following completion of the project. When an area is completed and ready for permanent cover, replace the topsoil from the stored stockpile along with required amendments (fertilizer specified) and then plant sod or seed the area as shown on the approved site plan.

Planning Considerations:

Existing native vegetation should be incorporated into the final landscape plan. It is adapted to the site, drought or wet tolerant, and will provide shade and erosion protection. Existing trees should be preserved as is where feasible and if encroachment is predicted, protected as per development requirements. If the area is not disturbed, then it does not require erosion control and concentrated flows down slope are greatly reduced. Creating natural vegetated buffer strips around the perimeter of a site can also reduce or eliminate off-site sedimentation.

Construction Specifications/Design Criteria:

- Designate areas of no disturbance. Clearly show on the plans, and flag in the field areas of no disturbance and construction vehicle exclusion.
- Designate trees and shrubs that are to be preserved.
- Designate watercourse buffer-filter strips on the site design plan.
- Maintain and preserve riparian and naturally vegetated buffer strips along watercourses as required
- If your project encroaches within 100 feet of a stream, wetland or waterbody, you must provide wetlands delineation.
- The Guide to Small Roads, USDA-SCS, also provides information for sizing buffer strips. The width of a buffer strip between a road and the stream is recommended to be 50 feet plus four times the slope of the land in percent, measured between the road and the top of stream bank. Buffer width in feet (m) = 50 + 4(% slope).
Example: For a 10% slope, buffer length is 50 feet + (4)(10) = 90 feet.

LAND GRADING FOR MINIMIZING EROSION – AVOIDING STEEP SLOPES

Definition:

Land grading for minimizing erosion is “grading that **is intended to minimize the impacts** of surface erosion and runoff”.

Purpose:

Where land grading is necessary for road or building construction, these land grading practices are intended to minimize the erosion potential and facilitate plant establishment.

Minimizing disturbance and creation of steep slopes

Minimizing the disturbance of or creation of steep slopes (30% or those 3H:1V, or greater) during development is a planning process for preservation of hydrology of the land and natural topography. The state permit requires that design consideration to avoid steep slope creation or disturbance is considered on project applications. The city will review site plans with this in mind.

Design Considerations:

Design considerations should include the following:

- Development should fit existing topography as much as possible so that land disturbance is minimized.
- Slope steepness and excessive slope lengths should be kept to a minimum. **Benches, steps, or contour furrows can be installed on long slopes to break up the slope length.**
- A bench should be graded back towards the slope and drain with a gentle gradient to a stable outlet.
- Drainage from upland areas must be diverted away from exposed slopes.
- Stabilization BMPs must be implemented **on exposed slopes within 7 days of completion** or temporarily if the land-disturbing activity on the slopes will not resume for 7 calendar days.

Construction Specifications:

- Only disturb, clear, or grade areas necessary for construction. Flag or otherwise delineate areas not to be disturbed. Exclude vehicles and construction equipment from these areas to preserve natural vegetation.
- All graded or disturbed areas including slopes shall be protected during clearing and construction in accordance with the approved erosion and sediment control plan until they are permanently stabilized.
- All sediment control measures shall be constructed and maintained in accordance with the approved erosion and sediment control plan and according to the standards and specifications for the appropriate erosion control practices.
- Areas to be filled should be cleared, grubbed to remove trees, vegetation, roots and other objectionable material, and stripped of topsoil. The outer face of the fill slope should be allowed to stay loose, not rolled, compacted, or bladed smooth. A bulldozer may run up and down the fill slope so the dozer treads (cleat tracks) create grooves perpendicular to the slope. If the soil is not too moist, excessive compaction will not occur.
- To reduce the length of cut-and-fill slopes and to limit sheet and rill erosion and to prevent gully erosion: use slope breaks, such as diversions, benches, or contour furrows as appropriate.
- Slopes in excess of 2:1 may require hydroseeding, hydromulching, tackifying, and/or "punching-in" straw, bioengineering techniques, or retaining walls.

- Roughen the surface of all slopes during the construction operation to retain water, increase infiltration, and facilitate vegetation establishment.
- Stabilize all graded areas with vegetation, crushed stone, riprap, or other ground cover as soon as grading is completed. For slopes stabilize within 7 days of slope creation or disturbance. If site is left unworked or idle for 14 days, you must stabilize within 7 days of that. Use mulch, temporary seeding, or blankets to stabilize areas temporarily where final grading must be delayed.
- Topsoil stockpiles, or other soil stockpiles, borrow areas and spoil areas shall be shown on the plans and shall be stabilized to prevent erosion and sedimentation. Additional BMPs may be required.

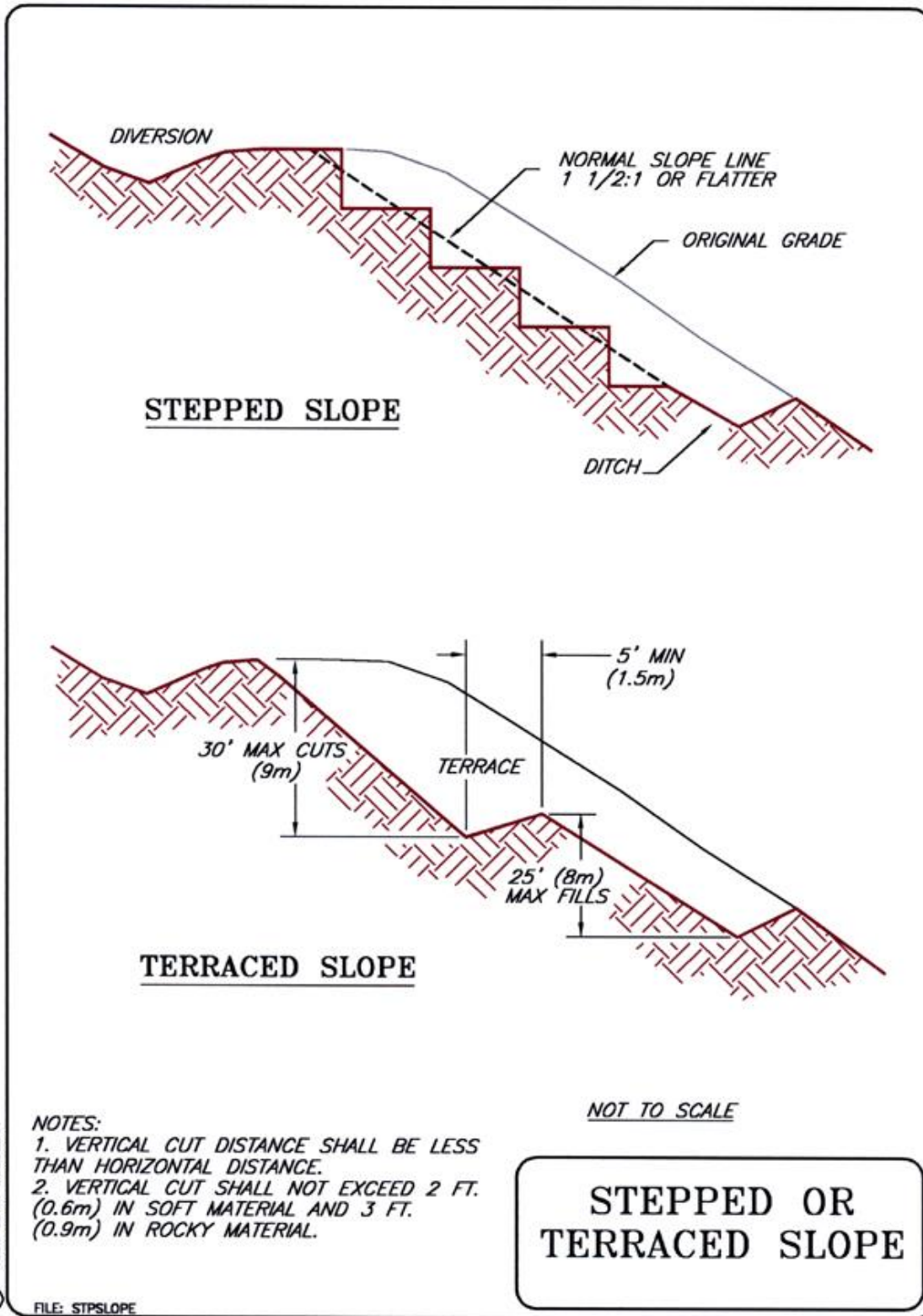

Typical drawing: Stepped or Terraced Slope

SURFACE ROUGHENING

Definition:

Surface Roughening is a technique for roughening a bare soil surface with furrows running across the slope, stair stepping, or tracking with construction equipment.

Purpose:

Surface Roughening is intended to aid the establishment of vegetative cover from seed, to reduce runoff velocity and increase infiltration, and to reduce erosion and provide for sediment trapping.



Conditions Where Practice Applies:

All construction slopes require surface roughening to facilitate long-term stabilization with vegetation, particularly slopes steeper than 3:1.

Planning Considerations:

Rough slope surfaces are preferred because they aid the establishment of vegetation, improve water infiltration, and decrease runoff velocity. Graded areas with smooth, hard surfaces may be initially attractive, but such surfaces increase the potential for erosion. A rough, loose soil surface gives a mulching effect that provides more favorable moisture conditions than hard, smooth surfaces; this aids seed germination.

There are different methods for achieving a roughened soil surface on a slope, and the selection of an appropriate method depends upon the type of slope. Roughening methods include stair-step grading, furrowing, and tracking. Factors to be considered in choosing a method are slope steepness, mowing requirements, and whether the slope is formed by cutting or filling.

Construction Specifications:

Cut Slope Roughening:

- Stair-step grade or groove the cut slopes that are steeper than 3:1.
- Use stair-step grading on any erodible material soft enough to be ripped with a bulldozer. Slopes consisting of soft rock with some subsoil are particularly suited to stair-step grading.
- Groove the slope using machinery to create a series of ridges and depressions that run across the slope, on the contour.

Fill Slope Roughening:

- Place fill slopes with a gradient steeper than 3:1 in lifts not to exceed 8 inches (0.2 m), and make sure each lift is properly compacted.
- Ensure that the face of the slope consists of loose, uncompact fill 4-6 inches (0.1-0.2 m) deep.
- Use grooving or tracking to roughen the face of the slopes, if necessary.

Apply seed, fertilizer and straw mulch then track or punch in the mulch with the bulldozer. Do not blade or scrape the final slope face.

Inspection and Maintenance:

Periodically check the seeded slopes for rills and washes. Fill these areas slightly above the original grade, then reseed and mulch as soon as possible.

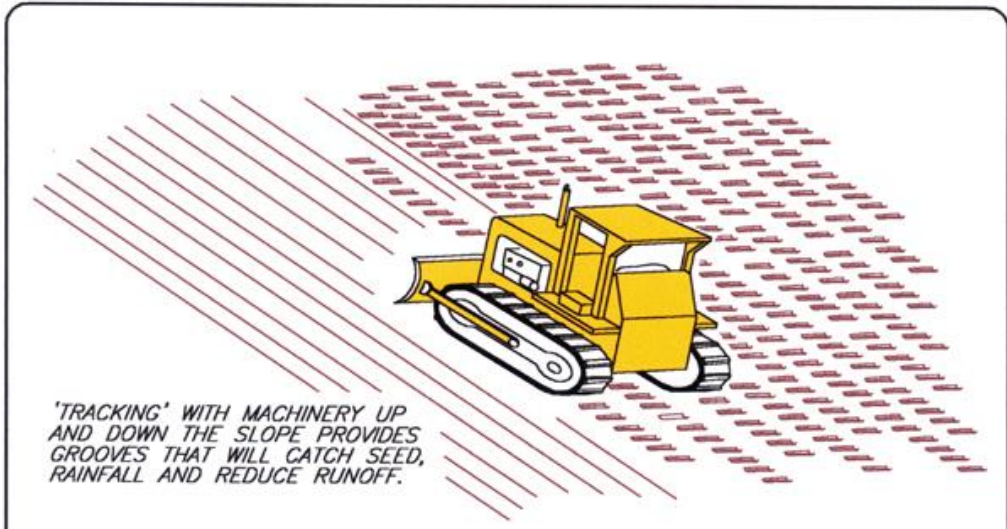

TRACKING

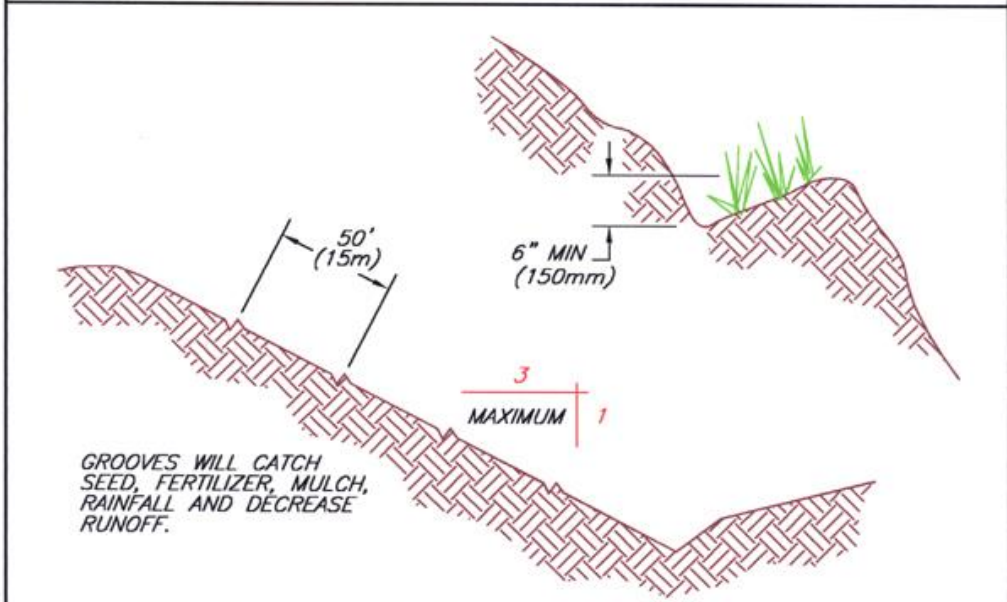

CONTOUR FURROWS

SURFACE ROUGHENING

© 1994 JOHN McCULLAH

FILE: SRFROUGH

Typical Drawing: Surface Roughening

TEMPORARY GRAVEL CONSTRUCTION ENTRANCE/EXIT

Definition:

A temporary gravel construction entrance/exit is a stabilized pad of crushed stone located at any point where traffic enters or leaves a construction site onto a public right-of-way, street, alley, sidewalk, or parking area.

Purpose:

A stabilized construction entrance is intended to reduce off-site sedimentation by eliminating the tracking or flowing of sediment onto public rights-of-way.

Design Considerations:

Construction plans should limit traffic to properly constructed and stabilized entrances, especially during wet weather operations.

Construction Specifications:

- The aggregate size for construction of the pad shall be 2 to 3-inch stone. Place the gravel to the specific grade and dimensions shown on the plans, and smooth it.
- The thickness of the pad shall not be less than 6 inches. Use geotextile fabrics, if necessary, to improve stability of the foundation in locations subject to seepage or high water table. The width of the pad shall not be less than the full width of all points of ingress or egress and in any case shall not be less than 12 feet wide. The length of the pad shall be as required, but not less than 50 feet for larger projects and 30 feet for individual residential lots.
- Locate construction entrances and exits to limit sediment leaving the site and to provide for maximum utility by all construction vehicles. Avoid entrances which have steep grades and entrances at curves in public roads.
- The entrance shall be maintained in a condition that will prevent tracking or flowing of sediment onto public rights-of-way. This may require periodic top dressing with additional stone as conditions demand, and repair and/or maintenance of any measures used to trap sediment.
- All sediment spilled, dropped, washed or tracked onto public rights-of-way shall be removed immediately.
- Provide drainage to carry water to a sediment trap or other suitable outlet.
- When necessary, wheels shall be cleaned to remove sediment prior to entrance onto public rights-of-way. When washing is required, it shall be done on an area stabilized with crushed stone that drains into an approved sediment trap or sediment basin.
- All sediment shall be prevented from entering any storm drain, ditch or watercourse through use of sand bags, gravel, straw bales, or other approved methods.

Inspection and Maintenance:

- Maintain the gravel pad in a condition to prevent mud or sediment from leaving the construction site.
- Replace gravel material when surface voids are visible.
- After each rainfall, inspect any structure used to trap sediment and clean it out as necessary.
- Immediately remove all objectionable materials spilled, washed, or tracked onto public roadways. Remove all sediment deposited on paved roadways within 24 hours.

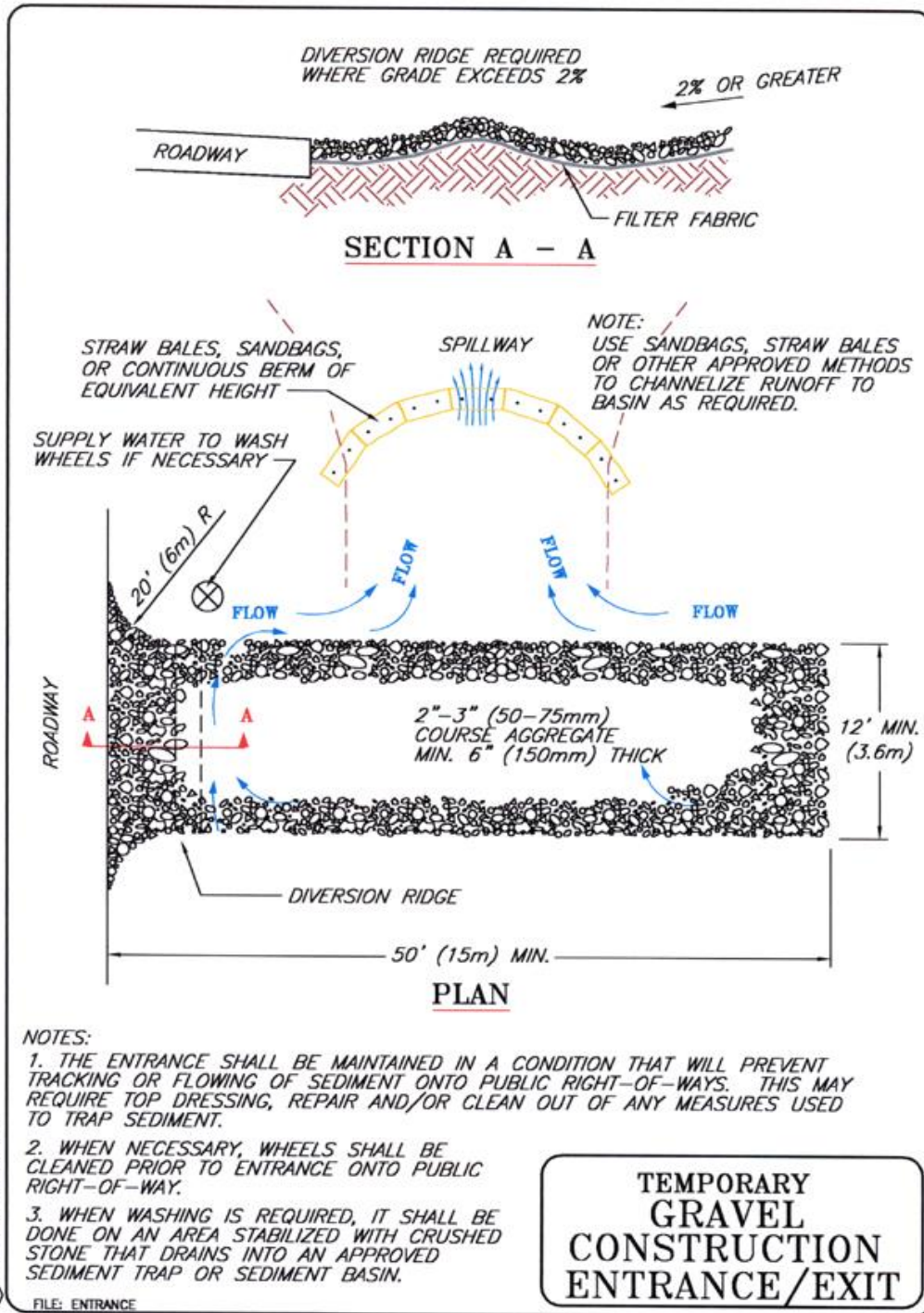

Typical Drawing: Temporary Gravel Construction Entrance/Exit

CHAPTER 3 VEGETATIVE ESTABLISHMENT BMPs

Vegetation as a Solution:

- Dense, healthy vegetation and the associated leaf litter protects the soil from raindrop impact. Raindrop impact is a major force in dislodging soil particles which then allows them to move downslope or form a crust on the soil surface. When a crust forms on the soil surface the rainfall infiltration rate decreases and runoff increases.
- Vegetation also protects the soil from sheet and rill erosion. It shields the soil surface from the transport of soil particles and scour from overland flow (sheet flow) and it decreases the erosive energy of the flowing water by reducing its velocity.
- The shielding effect of the plant canopy and leaves is augmented by roots and rhizomes that hold the soil in place, improve the soil's physical condition, and increase the rate of infiltration, further decreasing runoff. Plants also remove water from the soil through transpiration, thus increasing its capacity to absorb water.
- Suitable vegetative cover provides excellent erosion protection, and reduces the need for high cost and high maintenance sediment control measures.
- Exposed subsoils are generally difficult to amend, are infertile, and require more irrigation.

SEEDING FOR EROSION CONTROL: GENERAL SEEDING GUIDELINES

Timing Guide Lines:

Before planting all construction should be completed so as to not disturb the planting area. **Temporary Erosion Control Seeding** should be applied on sites intended to lie dormant for over 21 days. **Permanent Erosion Control Seeding** should be applied on sites intended to be dormant for over 1 year. **Mulch** can also provide for the short-term erosion control need. Both mulch and annual grasses provide a microclimate that is more suitable for the establishment of perennial plants.

Soil Amendments:

Before any soil amendments are applied on a site an appropriate soil test should be completed to determine appropriate lime and fertilization rates. It is important to provide minimum amounts of nitrogen (N), phosphorous (P), and potassium (K) to plants. This is especially true on disturbed sites that are generally deficient.

Quality of Seed Mixes:

Seeds containing prohibited or restricted noxious weeds should not be accepted. Seed should not contain in excess of 0.5% weed seed.

Seed should have a minimum acceptable pure live seed (PLS) of 80%. This is calculated by multiplying the minimum seed purity (%) and the minimum germination (%) rates from the seed tag. Divide by 100 to get the percent PLS.

For example: Seed 'A' is tagged 99.48% purity and 81% germination. Therefore,

$$(99.48 \times 81) / 100 = 80.57\% \text{ PLS}$$

which is within acceptable limits. Seeds with less than 80% PLS will require the quantity to seed be increased to meet specifications.

Appropriate Seeding rates for North Augusta

Spring / Summer is March 1- Aug. 14 and Fall / Winter is Aug. 15 – Feb. 28

SITE CONDITIONS	TEMPORARY GRASSING SPRING/SUMMER	PERMANENT GRASSING SPRING/SUMMER	TEMPORARY GRASSING FALL/WINTER	PERMANENT GRASSING FALL/WINTER
GRADUAL SLOPES	Browntop Millet 25# / acre	Hulled bermuda 30# / acre Browntop Millet 10# / acre	Rye grain 75# / acre	Unhulled Bermuda 40#/acre Rye grain 50# / acre
GRADUAL SLOPES / DEEP SAND	Browntop Millet 25# / acre	Hulled bermuda 40# / acre Browntop Millet 10# / acre Or Brunswick grass 25 # / acre Browntop Millet 10# / acre	Rye grain 100# / acre	Unhulled Bermuda 40#/acre Rye grain 75# / acre
GRADUAL SLOPES / HEAVY CLAY	Browntop Millet 25# / acre	Bahia grass 30# / acre Browntop Millet 10# / acre	Rye grain 75# / acre	Tall Fescue 35# / acre Rye grain 25# / acre
STEEP SLOPES	Browntop Millet 30# / acre Heavy wheat straw mulch	Hulled Bermuda 40# / acre Browntop Millet 15 / acre Or Bahia grass 30# / acre Hulled Bermuda 10# / acre Browntop Millet 25# / acre	Ryegrass 15# / acre Rye grain 100# / acre Heavy wheat straw mulch	Unhulled Bermuda 40#/acre Ryegrass 10# / acre Rye grain 75# / acre
STEEP SLOPES / DEEP SAND	Browntop Millet 30# / acre Heavy wheat straw mulch	Hulled Bermuda 40# / acre Browntop Millet 15 / acre Or Brunswick grass 30 # / acre Browntop Millet 15# / acre	Ryegrass 15# / acre Rye grain 100# / acre Heavy wheat straw mulch	Unhulled Bermuda 40#/acre Ryegrass 10# / acre Rye grain 75# / acre
STEEP SLOPES / HEAVY CLAY	Browntop Millet 30# / acre Heavy wheat straw mulch	Bahia grass 40# / acre Browntop Millet 15# / acre	Ryegrass 15# / acre Rye grain 100# / acre Heavy wheat straw mulch	Tall Fescue 50# / acre Ryegrass 5# / acre Rye grain 75# / acre
SLOPES WITH INFREQUENT MOWING / TALLER VEGETATION ACCEPTABLE (IE DETENTION POND SLOPES)	Browntop Millet 30# / acre Heavy wheat straw mulch	Hulled bermuda 20# / acre Browntop Millet 20# / acre Weeping Love grass 10# / acre Or Hulled Bermuda 20# / acre Sericea or Kobe Lespedeza 50 lb / acre Browntop Millet 15# / acre Or Sericea Lespedeza 50# / acre Weeping Love grass 10# / acre Browntop Millet 15# / acre	Ryegrass 15# / acre Rye grain 100# / acre Heavy wheat straw mulch	Unhulled Bermuda 40#/acre Weeping Love grass 10# / acre Rye grain 40# / acre Or Unhulled Bermuda 40# / acre Sericea Lespedeza (unhulled and unscarified) 50# / acre Rye Grain 40# / acre Or Weeping Love grass 10#/acre Sericea Lespedeza (unhulled and unscarified lespedeza) 50# / acre Rye grain 40# / acre

Planting Considerations:

- Seed should be planted at acceptable rates per SCDOT or by using the chart above.
- Seed should be drilled, harrowed, hydroseeded with a tackifier, or covered with mulch that is anchored by discing.
- If rainfall is not adequate, the area must be irrigated.
- For final stabilization, both temporary and permanent seed must be used.

HYDRAULIC PLANTING

Definition:

Hydraulic planting is a method of applying erosion control materials to bare soil and establishing erosion-resistant vegetation on disturbed areas and critical slopes.

Purpose:

By using hydraulic equipment (hydroseeders and hydromulchers) seed, soil amendments, wood fiber mulch and tackifying agents, bonded fiber matrix and liquid co-polymers can be uniformly broadcast, as a hydraulic slurry, onto the soil. These erosion and dust control materials can often be applied in one operation. Hydraulic planting is effectively used to establish vegetation intended to control erosion on steep, critical slopes that cannot practically be treated with other methods. Hydraulic planting techniques, such as hydroseeding and hydrosprigging, are also used to establish stands of turf grass.

Conditions Where Practice Applies:

Hydraulic planting is a very effective method for applying seed and mulch material. This practice will uniformly distribute seed which can then be covered with protective mulch, ensuring favorable conditions for quick germination and growth. Hydraulic planting is relatively more expensive than manual seeding and mulching, however, hydraulic planting generally requires less seedbed preparation - the soil surface may be left irregular with large clods, stones or rock outcroppings exposed.

Hydraulic planting techniques should be considered for temporary and permanent erosion control, seeding and mulching for sites with the following conditions:

- Slopes steeper than 3:1 that cannot receive adequate seedbed preparation and the mulch would be difficult to otherwise anchor.
- Where the slope surface is irregular with large clods, stones or a high percentage of rock.
- Where site conditions such as, irregular soil surfaces, existing vegetation, and shallow soils preclude the installation of erosion control blankets and mats.
- On sites where other soil stabilization, seeding, and mulching practices would require unacceptable levels of disturbance.
- On sites where it is desirable to apply water, seeds and mulch in one operation.
- On critical erosion sites where the application of seed, fiber, fertilizer followed by the application of straw mulch and tackifier (the three-step process) is desirable.
- On sites where straw mulch has been applied and the straw needs to be anchored (tacked) with tackifiers or hydraulic mulches.
- On sites where dust control is desired.

Design Considerations:

Hydraulic machines are used to spray seed, tack down straw, bind the soil, seal the soil, or apply blanket-like coats of bonded fiber matrix (BFM). These materials are usually applied by spraying a slurry, often in one application.

Types of Hydraulically Applied Materials for Erosion and Dust Control:

Seed and Fertilizer: Applying seed and fertilizer with water has many benefits. The seed blend can be distributed uniformly, the added mass increases accuracy and throw distance, especially for exposed, windy areas, and the presoaking and water accelerates germination and enhances the chance of survival. **Mulches:** Hydraulically applied mulches include mulches made from wood fibers, paper fibers, combination recycled wood and paper fibers, and polyester and/or polypropylene fibers.

Tackifiers: Tackifiers are typically used to anchor or glue mulch to increase effectiveness of erosion control. Tackifiers used in conjunction with straw mulch are extremely effective in bonding the straw to itself and the soil surface, thus resisting movement by water or wind. Liquid formulations of acrylic copolymers can also be specified alone to control erosion and dust. These products chemically bond and stabilize the soil surface.

Cementitious Binders: These products are formulated from hydrated lime or gypsum mixed with water and applied to the soil with hydraulic equipment. Fiber mulch, seed and fertilizers can be applied with the slurry and sprayed on in one application. These cementitious binders form a permeable crust on the soil surface which control water and wind erosion.

Bonded Fiber Matrix (BFM): Hydraulic matrix products are typically produced from longer fibers combined with tackifiers and binding agents that are hydraulically applied and conform to the ground and dry to form a bonded fiber matrix. Seed and fertilizer can be added to the slurry and applied with the BFM in one-step application.

Site Preparation:

Grade as needed and feasible to permit the use of equipment for seedbed preparation. Install needed erosion control practices, such as sediment basins, diversion dikes and channels, prior to seeding. Divert concentrated flows away from hydraulic planted areas. Conduct soil tests to determine pH. Add amendments as necessary to adjust pH. The seedbed should be firm but not compact. The top 3 inches of soil should be loose, moist and free of large clods and stones.

Planting:

- Seed to soil contact is important for successful germination.
- Use dormant seeding techniques for late fall or winter seeding schedules.
- Use seed rates based on pure live seed (PLS) of 80%. When PLS is below 80%, adjust rates accordingly.

Hydraulic Mulching:

The mulch should be mixed with seed, fertilizer and additives as specified and applied at a rate recommended by the manufacturer in order to achieve uniform, effective coverage and provide adequate distribution of seed. Apply straw mulch binders (tackifiers) heavier at the edges, in valleys and at the crest of banks.

Inspection and Maintenance:

- Hydraulically treated areas shall be inspected and monitored after installation and periodically thereafter.
- If the hydraulic mulch or tackifiers were applied as standalone (without vegetation) treatments for erosion and dust control, the products longevity must match the length of time that the soil will remain bare or until revegetation occurs. Periodic inspections will assure the intended purposes will be met.
- Areas which fail to establish cover adequate to prevent erosion shall be reseeded and re-mulched as soon as such areas are identified.

MULCHING

Definition:

Mulching is the application of a protective layer of straw or other suitable material to the soil surface. Straw mulch and/or hydromulch is also used in conjunction with seeding and hydroseeding of critical areas for the establishment of temporary or permanent vegetation. Mulching with straw or fiber mulches is commonly used as a temporary measure to protect bare or disturbed soil areas that have not been seeded.

Purposes:

To temporarily stabilize bare and disturbed soils, to protect the soil surface from raindrop impact, to increase infiltration, to conserve moisture, to prevent soil compaction or crusting, and to decrease runoff. Mulching also fosters growth of vegetation by protecting the seeds from predators, reducing evaporation, and insulating the soil.

Design Considerations:

Mulch can be applied to any site where soil has been disturbed and the protective vegetation has been removed. The most common use of mulch is to provide temporary stabilization of soil, usually until permanent stabilizing vegetation is established. Where mulches are used to compliment vegetation establishment, they should be designed to last as long as it takes to establish effective vegetative erosion control. Where mulches are used as surface cover only (i.e. bark, wood chips, or straw mulch cover) the serviceable duration of the application and maintenance requirements, including augmentation or replication should be specified. On steep slopes, greater than 2.5:1, or where the mulch is susceptible to movement by wind or water, the mulch material should be hydraulically applied or the straw mulch should be appropriately anchored. Hydraulic fiber mulches and/or tackifying agents are used effectively to bind the straw together and prevent displacement by wind or rain.

Construction Specifications:

- Straw:

Straw is an excellent mulch material. Because of its length and bulk, it is highly effective in reducing the impact of raindrops and in moderating the microclimate of the soil surface. Straw mulch can be applied by hand on small sites and blown on by machine on large sites. Mulch should not be applied more than 2 inches deep on seeded sites, unless it is incorporated into the soil by tracking, disking, or other 'punching in' techniques.

Anchoring

Straw mulch must be anchored immediately to minimize loss by wind or water. Straw mulch is commonly anchored by:

1. crimping, tracking, disking, or punching into the soil;
2. covering with a netting;
3. spraying with asphaltic or organic tackifier;
4. tacking with cellulose fiber mulch at a rate of 750 lbs./ac.

- Hydraulic Mulches from Wood and Paper Fiber:

These combination mulches are generally comprised of 70% wood fiber and 30% paper fiber, manufactured from lumber mill waste, virgin wood chips, recycled newsprint, office paper and other waste paper. The mulch is mixed in a hydraulic application machine (hydroseeder) and applied as slurry in combination with the recommended seed and fertilizer. The mulch can be specified with or without a tackifier.

Inspection and Maintenance:

If properly applied and anchored, little additional maintenance is required during the first few months. After high winds, or significant rainstorms, mulched areas should be checked for adequate cover and re-mulched if necessary. Mulch needs to last until vegetation develops to provide permanent erosion resistant cover. Straw mulch can last from 6 months to 2 years. Erosion control blankets are effective for up to two years.

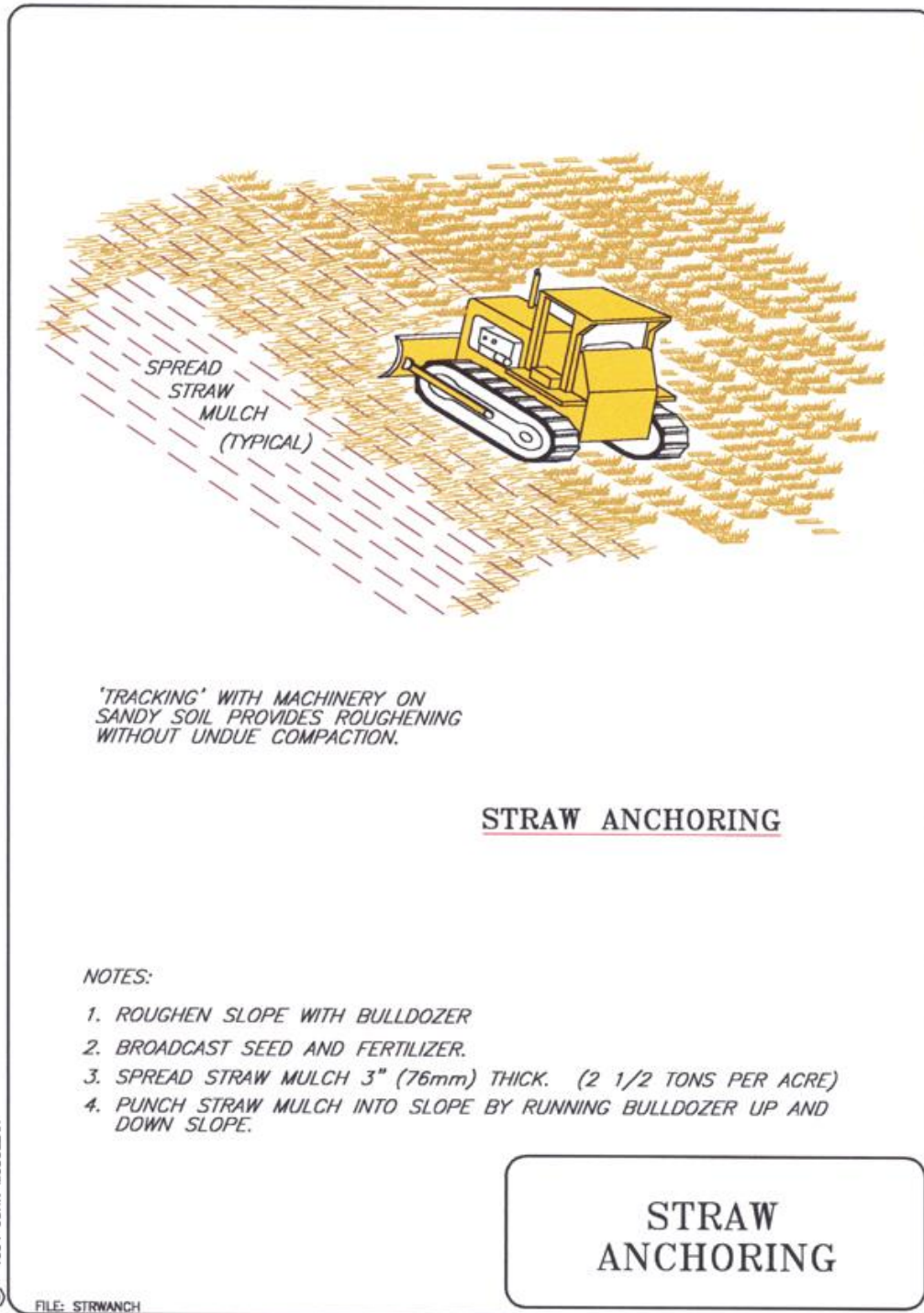

NOTES:

- 1. ROUGHEN SLOPE WITH BULLDOZER*
- 2. BROADCAST SEED AND FERTILIZER.*
- 3. SPREAD STRAW MULCH 3" (76mm) THICK. (2 1/2 TONS PER ACRE)*
- 4. PUNCH STRAW MULCH INTO SLOPE BY RUNNING BULLDOZER UP AND DOWN SLOPE.*

**STRAW
ANCHORING**

Typical Drawing: Straw Anchoring

CHAPTER 4 STORMWATER CONVEYANCE BMPs

GRASSED-LINED CHANNELS

Definition:

Vegetation lining a natural or constructed waterway, swale or dike to protect it from erosion.

Purpose:

Grass protection of drainage ways reduces erosion by lowering water velocity over the soil surface and by binding soil particles with roots. The drainage way is any ground surface over which concentrated runoff travels. It is typically a manmade waterway, swale or ditch. It may also be the upslope flow of water and directs the concentrated flow along the surface of the barrier.

Grass-lined channels should be used where:

- A vegetative lining can provide sufficient stability for the channel grade by increasing maximum permissible velocity;
- Slopes are generally less than 5%;
- Site conditions required to establish vegetation i.e., climate, soils and topography are present.

Grass lined channels may be reinforced using either:

- Cellular confinement systems (geocells) which significantly improve the hydraulic performance of vegetation by confining the soil layer within the cellular structure. Confinement and anchorage of the root structure increases the limiting shear resistance of the protection and the permissible flow duration. Geocell systems are recommended for swales, ditches and on upper slopes of large channels where flows are intermittent, of low to moderate intensity, and of relatively short duration (<24 hours).
- Erosion control blankets which can be selected for low to medium velocity intermittent flows. Permanent to temporary biodegradable options are available. Proper installation of ECBs is crucial to long-term success. Channels with design velocities greater than 2 ft./sec. will require that turf reinforcement mats, erosion control blankets, or netting be installed at the time of seeding to provide stability until the vegetation is fully established. It may also be necessary to divert water from the channel until vegetation is established or to line the channel with sod. Whenever design velocities exceed 4 ft./sec. a permanent type of erosion control blanket or turf reinforcement mat will be necessary.

Design Considerations:

Grass-lined channels resemble natural systems and are usually preferred where design velocities are suitable. Select appropriate vegetation and construct channels early in the construction schedule before grading and paving increase runoff rates. Generally, grass-lined channels are constructed in stable, low areas to conform to the natural drainage system, but they may also be needed along roadways or property boundary. To reduce erosion potential, design the channel to avoid sharp bends and steep grades. The channel cross section should be wide and shallow with relatively flat side slopes so surface water can enter over the vegetated banks without erosion. Riprap may be needed to protect the channel banks at intersections where flow velocities approach allowable limits and turbulence may occur. Cross-section designs include:

- V-shaped
Generally used where the quantity of water is relatively small, such as roadside ditches. The V-shaped cross section is desirable because of difficulty stabilizing the bottom, where velocities may be high. A grass or sod lining will suffice where velocities are low or rock or riprap lining may be necessary.

- **Parabolic**
Often used where larger flows are expected and sufficient space is available. The shape is pleasing and may best fit site conditions. Riprap should be used where higher velocities are expected and where some dissipation of energy (velocity) is desired. Combinations of grass with riprap centers or turf reinforcement mat centers are useful where there is a continuous low flow in the channel.
- **Trapezoidal**
Used where runoff volumes are large and slope is low so that velocities are non-erosive to vegetated linings. Trapezoidal channels generally have concrete or riprap lined center for low flow.

Grass-lined channels must not be subject to sedimentation from disturbed areas. An established grass-lined channel resembles natural drainage systems and is usually preferred if design velocities are below 5 ft./sec. Outlets should function with a minimum of erosion. Sediment traps may be needed at channel inlets and outlets to prevent sedimentation.

Additional Design Criteria:

- **Capacity:** Sufficient to convey 10 year - 24 hour storm.
- **Velocity:** The allowable design velocity for grass-lined channels is based on soil conditions, type of vegetation, and method of establishment. If design velocity of a channel to be vegetated exceeds 2-4 ft./sec., a channel liner is required.
- **Depth:** The design water surface elevation of a channel receiving water from diversions or other tributary channels shall be equal to or less than the design water surface elevation of the diversion or other tributary channel at the point of intersection.
- **Cross-section:** The channel shape may be parabolic, trapezoidal, or V-shaped, depending on need and site conditions.
- **Side Slopes:** Grassed channel side slopes generally are constructed 3:1 or flatter to aid in the establishment of vegetation and for maintenance.
- **Grade:** Generally restricted to slopes 5% or less. Either a uniform or gradually increasing grade is preferred to avoid sedimentation.

Inspection and Maintenance:

- During the initial establishment, grass-lined channels should be repaired and grass re-established if necessary.
- After grass has become established, the channel should be checked periodically to determine if the channel is withstanding flow velocities without damage.
- Check the channel for debris, scour, or erosion and immediately make repairs. It is particularly important to check the channel outlet and all road crossings for bank stability and evidence of piping or scour holes and make repairs immediately.
- Remove all significant sediment accumulations to maintain the designed carrying capacity.
- Keep the grass in a healthy, vigorous condition at all times, since it is the primary erosion protection for the channel. Permanent grassed waterways should be seasonally maintained by mowing, depending on the type of vegetation selected.

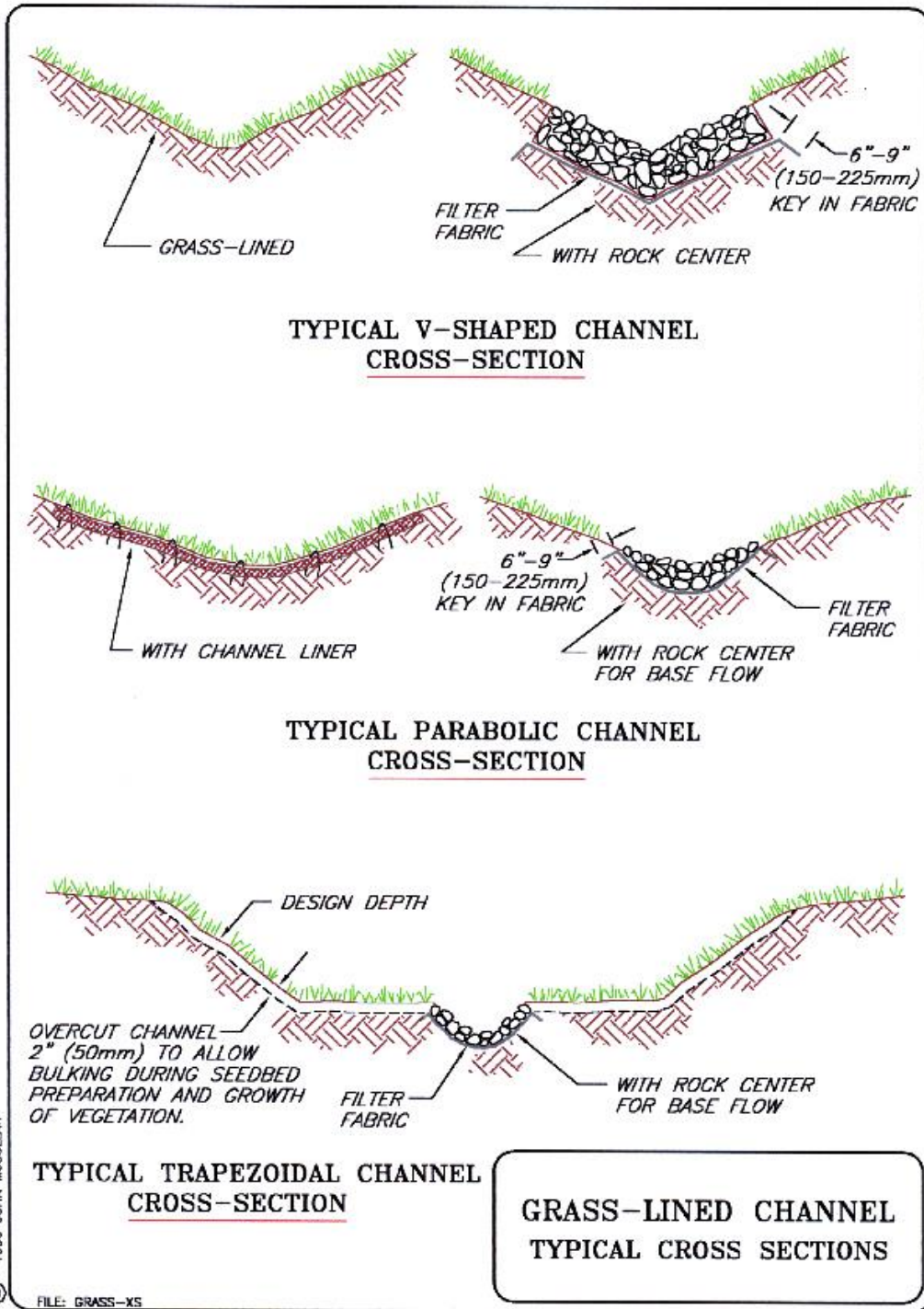

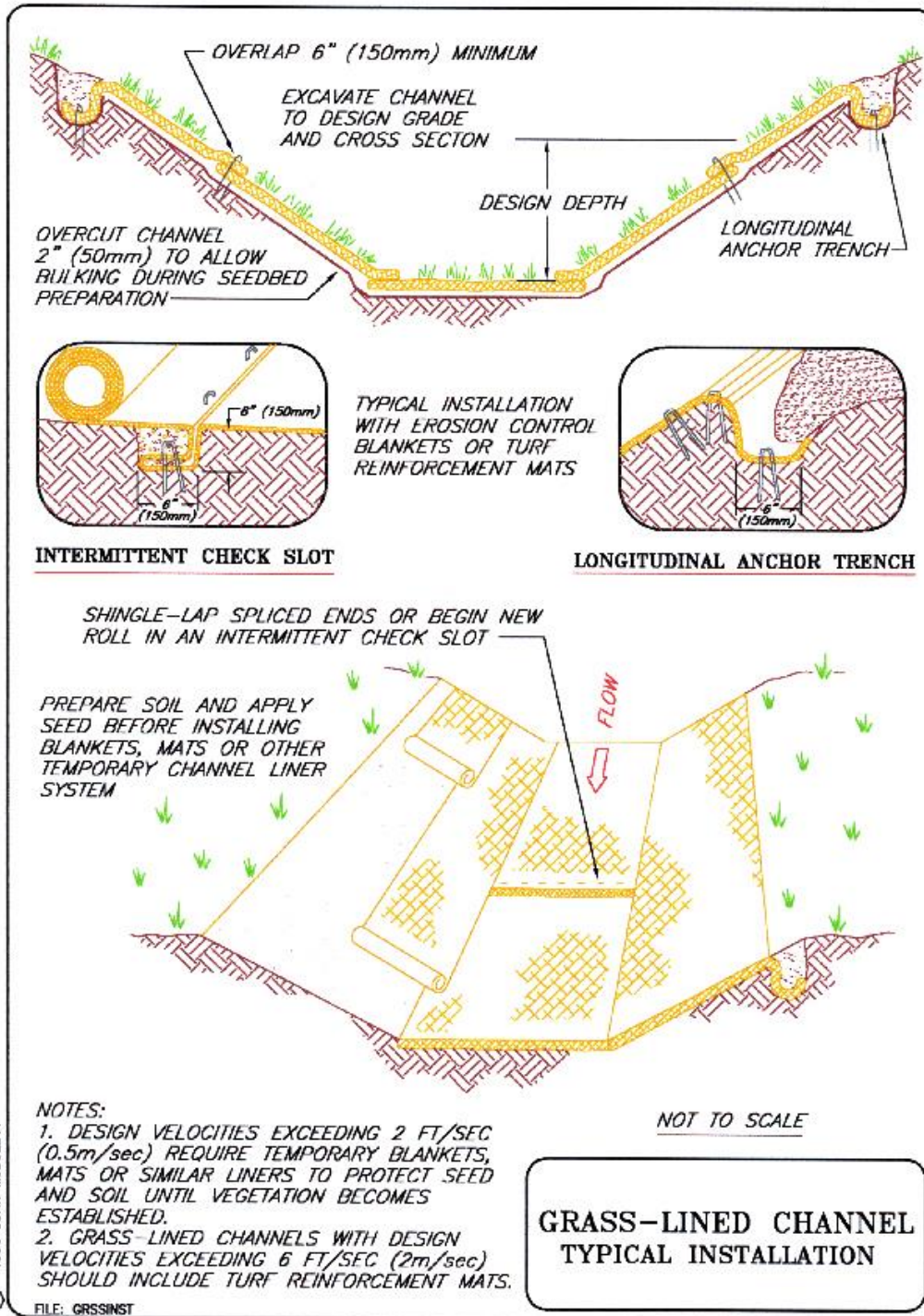

Typical Drawing: Grass-Lined Channel Installation

ROCK LINED CHANNEL

Definition:

Rock-lined channels are channels or roadside ditches lined with rock or riprap.

Purpose:

To convey concentrated surface runoff without erosion.

Conditions Where Practice Applies:

- This practice applies where design flow exceeds 2 ft./sec (.61 m/sec) such that channel lining is required, but conditions are not suitable for vegetative protection. Specific conditions include:
- All roadside ditches or drainage channels greater than 2% and located in highly erodible soils that have a low maximum permissible velocity.
- The channel design velocity exceeds that allowable for a grass-lined channel.
- The channel will continue to down-cut without protection because it is adjusting to increased flow or a new base line (outlet elevation).

Design Criteria:

- Capacity: peak runoff from 10-year storm.
- Side slopes: 2:1 or flatter.
- Stone size: $d = 2$ inch (50 mm) minimum. Use engineering design procedures for sizing riprap for large or critical drainage channels. Riprap thickness: $T = 1.5$ times the stone diameter or as shown on the plans; 6 inch (150 mm) thick minimum.
- Foundation: Extra-strength filter fabric or an aggregate filter layer, if required.
- Outlet must be stable.

Construction Specifications:

- Excavate cross section to the grades shown on plans. Overcut for thickness of rock and filter.
- Place filter fabric or gravel filter layer, and rock as soon as the foundation is prepared.
- Place rock so it forms a dense, uniform, well-graded mass with few voids. Hand placement may be necessary to obtain good size distribution.
- Channel outlet shall be stabilized.

Inspection and Maintenance:

Inspect channels at regular intervals and after major storms. Remove debris and make needed repairs where stones have been displaced. Take care not to restrict the flow area when stones are replaced. Give special attention to outlets and points where any concentrated flow enters the channel. Repair eroded areas promptly. Check for sediment accumulation, piping, bank instability, and scour holes and repair promptly.

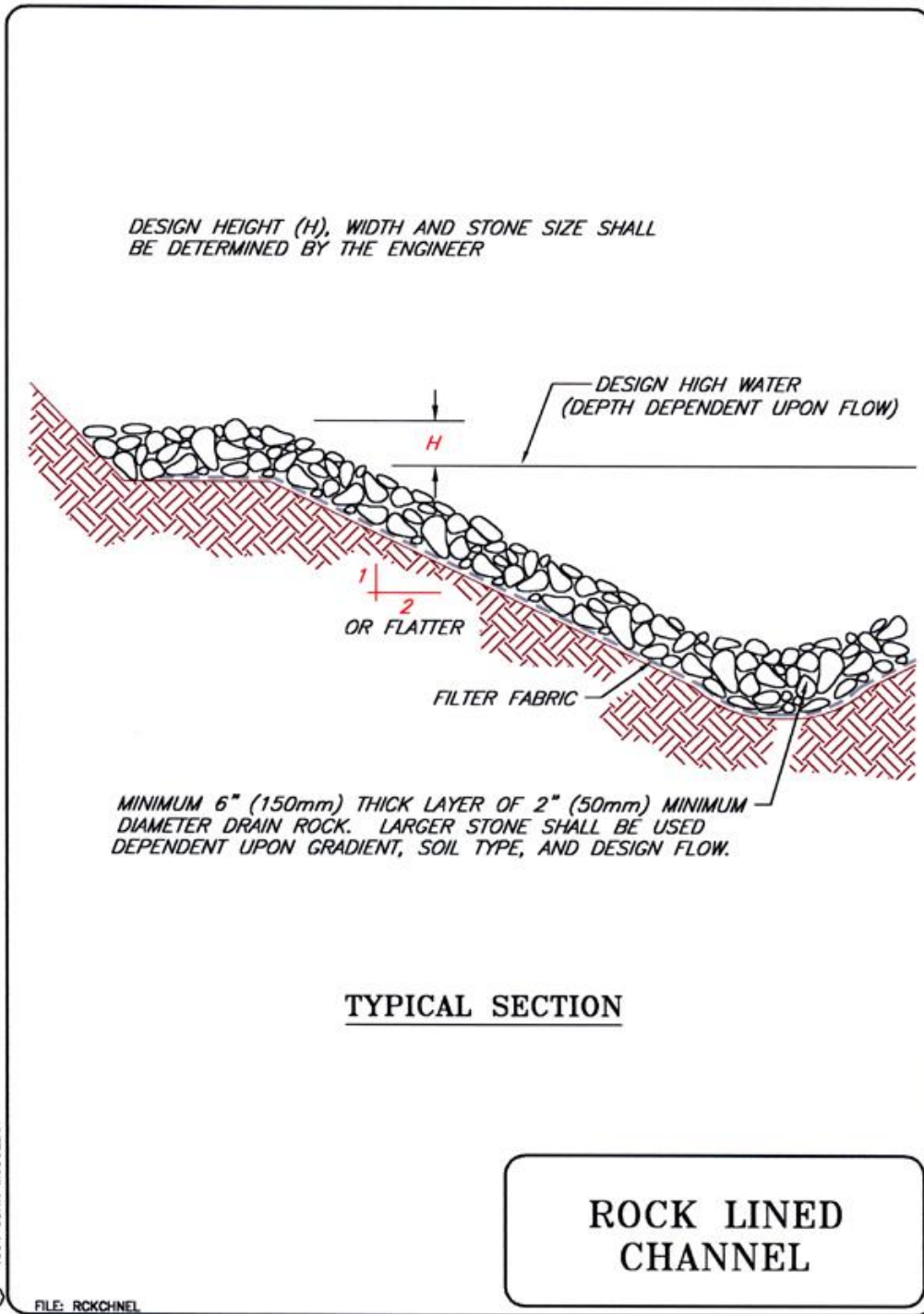

Typical Drawing: Rock Lined Channel

TEMPORARY DIVERSION DIKE

Definition:

A temporary ridge of compacted soil constructed immediately above a new cut or soil fill slope or around the perimeter of a disturbed area.

Purposes:

- To divert storm runoff from upslope drainage areas away from unprotected disturbed areas and slopes to a stabilized outlet.
- To divert sediment-laden runoff from a disturbed area to a sediment-trapping facility such as a sediment trap or sediment basin.
- An upslope dike can improve working conditions at the construction site and prevent erosion.
- A downslope dike assures that sediment-laden runoff will not leave the site without treatment.

Planning Considerations:

It is very important that a temporary diversion dike be stabilized immediately following installation with temporary or permanent vegetation to prevent erosion of the dike itself. The gradient must have a positive grade to assure drainage, but if the gradient is too great, precautions must be taken to prevent erosion due to high velocity channel flow behind the dike.

Temporary diversion dikes are often used as a perimeter control in association with a sediment trap or a sediment basin, or a series of sediment-trapping facilities, on moderate to large construction sites. If installed properly and in the first phase of grading, maintenance costs are very low.

Design Considerations:

Drainage Area: 5 acres or less recommended Dike Design:

side slope:	2:1 or flatter
width:	2 foot (.6 m) (top width) minimum
height:	1.5 feet (.5 m) minimum
freeboard:	0.5 feet (.2 m) minimum

Grade:

The channel behind the dike shall have a positive grade to a stabilized outlet. If the channel slope is less than or equal to 2%, no stabilization is required. If the slope is greater than 2%, the channel shall be stabilized.

Outlet:

Divert sediment-laden water into a temporary sediment trap or sediment basin. Runoff from undisturbed areas should empty into an outlet protection unless well stabilized natural outlets exist.

Construction Specifications:

- Temporary diversion dikes must be installed as a first step in the land-disturbing activity.
- The dike should be adequately compacted to prevent failure.
- Temporary or permanent seeding and mulch shall be applied to the dike immediately following its construction.

Inspection and Maintenance:

- The measure shall be inspected after every storm and repairs made to the dike, flow channel, outlet or sediment trapping facility, as necessary.
- Diversion Dikes used to trap sediment shall be inspected and cleaned out after every storm.
- If vegetation has not been established, reseed damaged and sparse areas immediately.

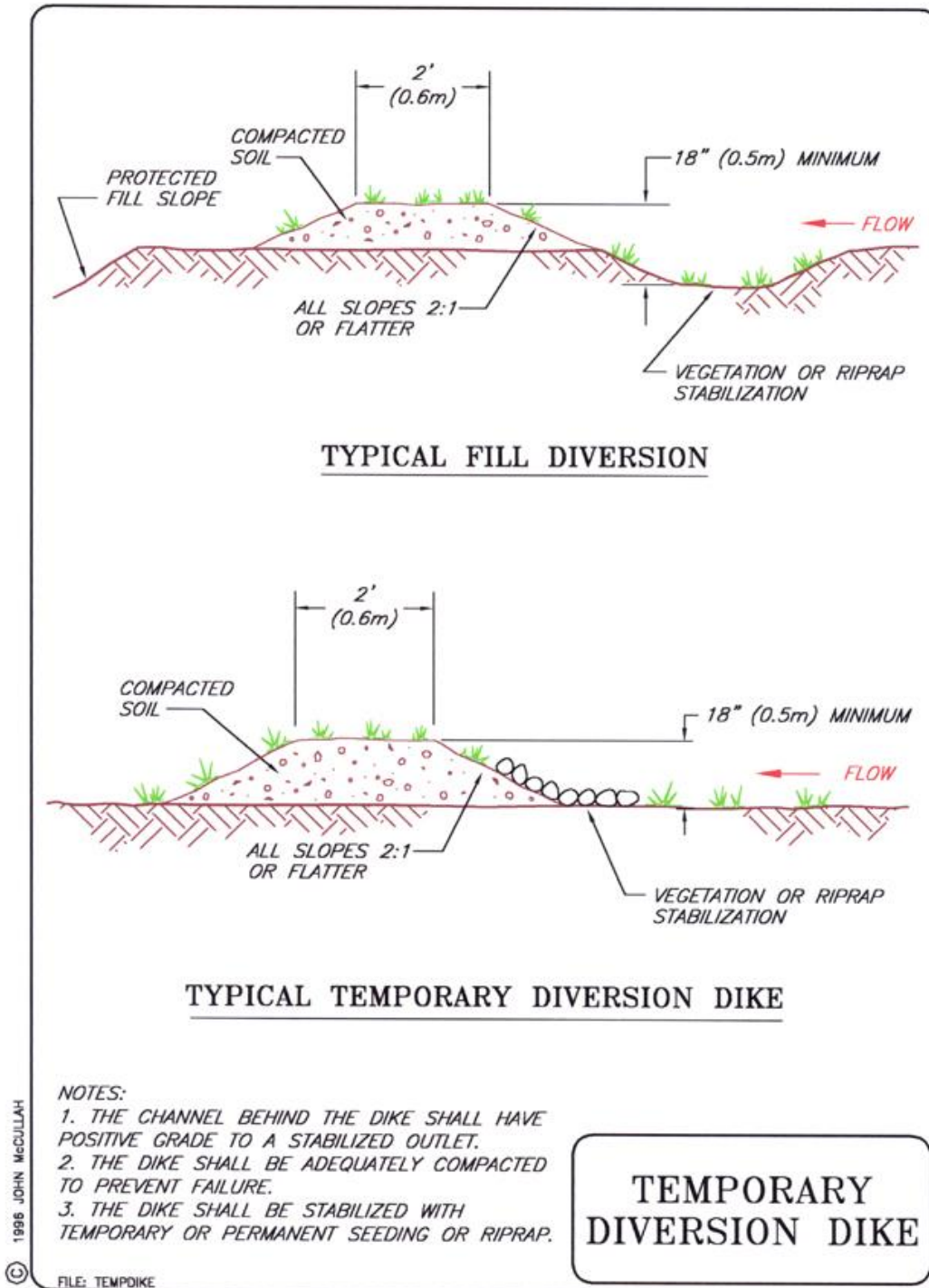

Typical Drawing: Temporary Diversion Dike

SLOPE DRAIN

Definition:

A temporary slope drain is a flexible tubing, pipe, over side drain, or other conduit extending from the top to the bottom of a cut or fill slope.

Purpose:

To convey concentrated runoff down the face of a cut or fill slope without causing erosion.

Conditions Where Practice Applies:

This practice applies to construction areas where stormwater runoff above a cut or fill slope will cause erosion if allowed to flow over the slope. Temporary slope drains are generally used in conjunction with diversions to convey runoff down a slope until permanent water disposal measures can be installed

Planning Considerations:

Constructed slopes are often exposed to erosion between the time they are graded and permanently stabilized. During this period, the slope is very vulnerable to erosion, and temporary slope drains together with temporary diversions can provide valuable protection. It is very important that these temporary structures be sized, installed, and maintained properly, because their failure will usually result in severe erosion of the slope. The entrance section to the drain should be well-entrenched and stable so that surface water can enter freely. The drain should extend downslope beyond the toe of the slope to a stable area or appropriately stabilized outlet. Other points of concern are failure from overtopping from inadequate pipe inlet capacity and lack of maintenance of diversion channel capacity and ridge height.



Failed slopes with no slope drains. Result, increase in workload and costs. Most importantly, offsite impacts and non-compliance issues can delay your project.

Design Criteria:

Capacity: Peak runoff from the 10-year storm. See reference material for determining the peak runoff.

Pipe size: Unless they are individually designed, size drains according to the Table below.

Maximum Drainage Area per pipe	Pipe Diameter inches (meters)
0.50 ac. (0.20 ha)	12 (.36)
0.75 ac. (0.30 ha)	15 (0.45)
1.00 ac. (0.40 ha)	18 (0.54)
>1.00 ac* (>0.40 ha)	as designed

*Inlet design becomes more complex beyond this size.

- Conduit: Construct the slope drain from heavy-duty, flexible materials such as non-perforated, corrugated plastic pipe, or open top over side drains with tapered inlets, or CMP. Install reinforced,

hold-down grommets or stakes to anchor the conduit at intervals not to exceed 10 feet (3 m) with the outlet end securely fastened in place. CMP or corrugated plastic pipe must have one (1) anchor assembly for every 20 feet (6 m) of slope drain. The conduit must extend beyond the toe of the slope.

- Entrance: Construct the entrance to the slope drain of a standard flared-inlet section of pipe with a minimum 6 inch (150 mm) metal toe plate. Make all fittings watertight. A standard T-section fitting may also be used at the inlet. An open top flared inlet for over side drain may also be used.
- Temporary Diversion: Generally, use an earthen diversion with a dike ridge or berm to direct surface runoff into the temporary slope drain. Make the height of the ridge over the drain conduit a minimum of 1.5 feet (0.5 m) and at least 6 inches (150 mm) higher than the adjoining ridge on either side. The lowest point of the diversion ridge should be a minimum of 1 foot (300 mm) above the top of the drain so that design flow can freely enter the pipe.
- Outlet Protection: Protect the outlet of the slope drain from erosion with an energy dissipater.

Construction Specifications:

- A common failure of slope drains is caused by water saturating the soil and seeping along the pipe. Proper backfilling around and under the pipe haunches with stable soil material and hand compacting in 6 inch (150 mm) lifts to achieve firm contact between the pipe and the soil at all points will reduce this type of failure.
- Place slope drains on undisturbed soil or well-compacted fill at locations and elevations shown on the plans.
- Slightly slope the section of pipe under the dike toward its outlet.
- Compact the soil under and around the entrance section in lifts not to exceed 6 inches (150 mm).
- Ensure that fill over the drain at the top of the slope has a minimum depth of 1.5 feet (0.5 m) and a minimum top width of 4 feet (1 m). The sides should have a 3:1 slope.
- Ensure that all slope drain connections are watertight.
- Ensure that all fill material is well compacted. Securely fasten the exposed section of the drain with grommets or stakes spaced no more than 10 feet (3 m) apart.
- Extend the drain beyond the toe of the slope and adequately protect the outlet from erosion.
- Make the settled, compacted dike ridge no less than 1 foot (300 mm) higher than the top of the pipe inlet.
- Immediately stabilize all disturbed areas following construction.

Inspection and Maintenance:

Inspect the slope drain and supporting diversions after every significant rainfall and promptly make necessary repairs. When the protected area has been permanently stabilized, temporary measures may be removed, materials disposed of properly, and all disturbed areas stabilized appropriately.

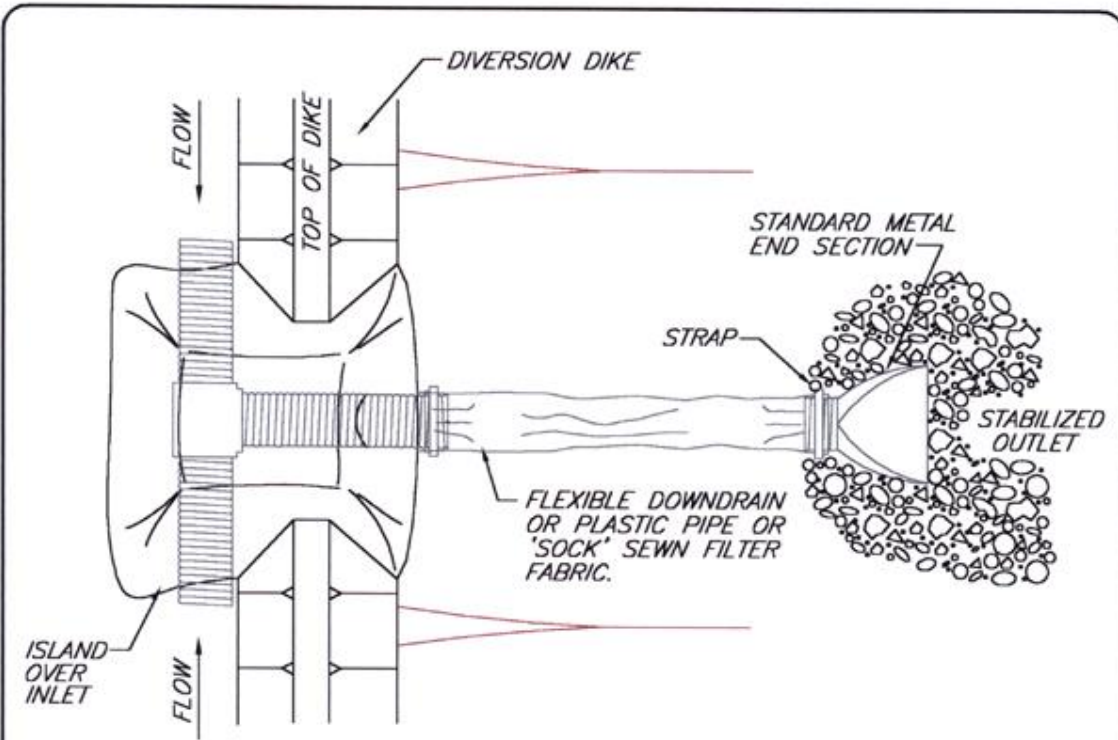

PLAN VIEW

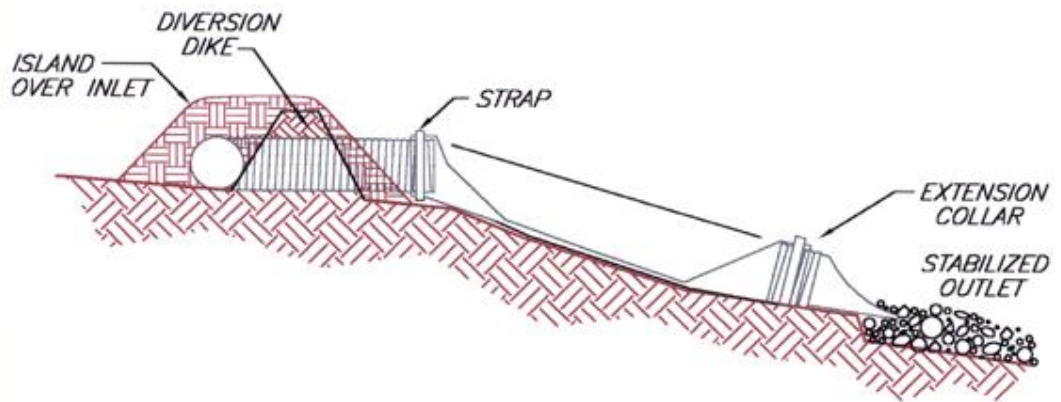

SECTION

SLOPE DRAIN

© 1994 JOHN McCULLAH

FILE: SLOPEDRN

Typical Drawing: Slope Drain

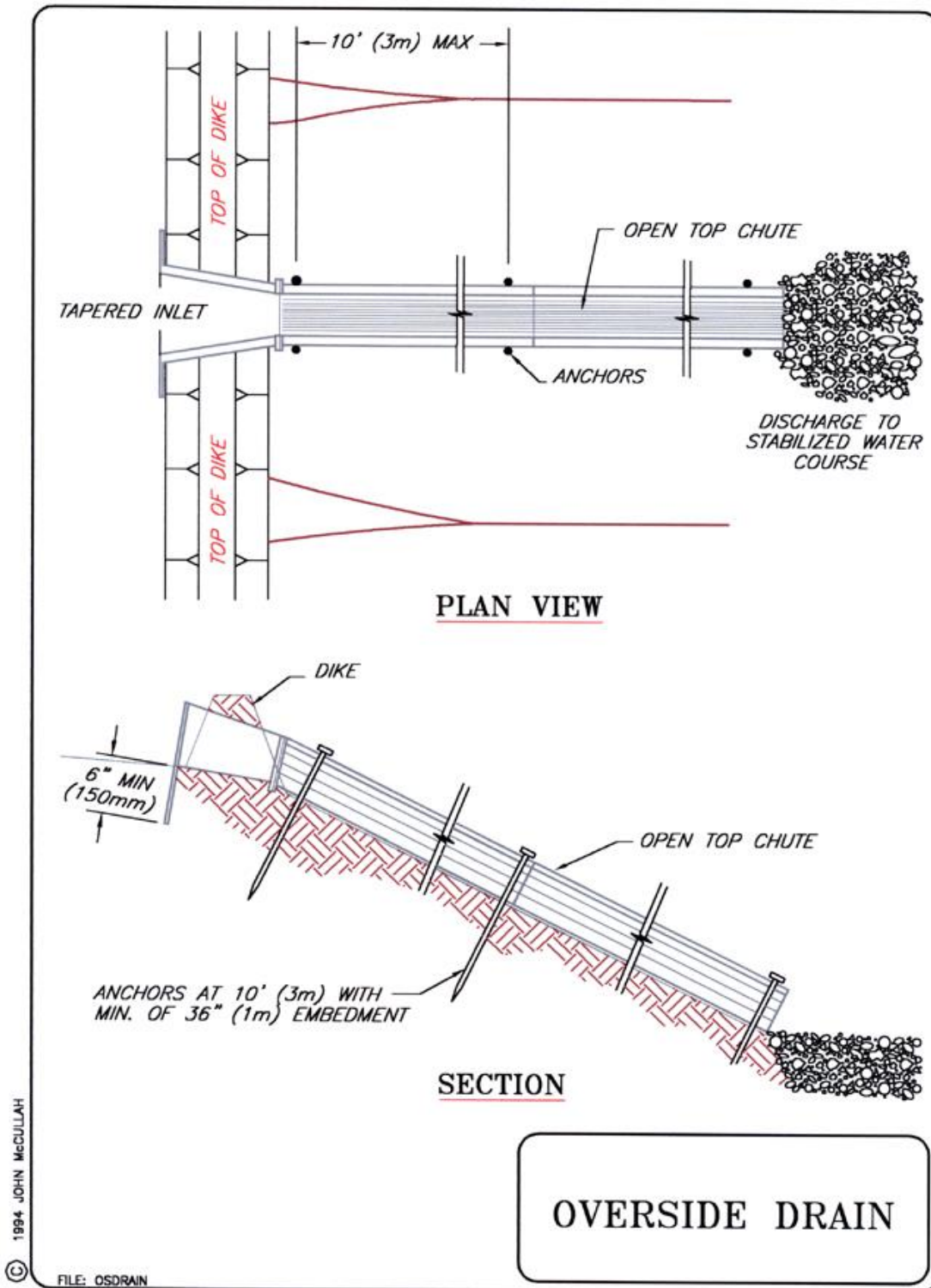

Typical Drawing: Overside Drain

WATERBARS AND ROLLING DIPS

Definition:

Waterbars and rolling dips are ridges or ridge-and-channels constructed diagonally across a sloping road or utility right-of-way that is subject to erosion.

Purpose:

To limit the accumulation of erosive volumes of water on roads by diverting surface runoff at predesigned intervals.

Planning Considerations:

Construction of access roads, power lines, pipelines, and other similar installations often requires clearing long narrow right-of-ways over sloping terrain. Roads concentrate runoff. Gully formation may be especially severe in tire tracks and ruts. To prevent gully erosion, runoff can often be diverted across the width of the right-of-way to undisturbed areas by using waterbars or rolling dips. A **waterbar** is a berm and excavation built diagonally across the road. Waterbars generally become less effective if driven over during wet weather, and are difficult to cross with low clearance vehicles. **Rolling dips** are gently sloping excavations running diagonally across the road surface, and are more appropriate for winter use. Rolling dips are more difficult to construct, but are much easier to traverse and require less maintenance. Give special consideration to each individual outlet area, as well as to the cumulative effect of added diversions. Never outlet waterbars or rolling dips onto unprotected fill slopes. Use gravel to stabilize the diversion where significant vehicular traffic is anticipated.

Design Criteria:

- Waterbar Height: 18 inch (0.5 m) minimum measured from the channel bottom to the ridge top.
- Side Slope: 2:1 or flatter; 3:1 or flatter where vehicles cross.
- Base width of ridge: 6 foot (2 m) minimum.
- Spacing of waterbars/rolling dips is shown in the Table below.

Slope (%)	Spacing ft. (m)	Spacing High Erodible ft. (m)
<5	125 (38.1)	100 (30.5)
5 to 10	100 (30.5)	75 (22.9)
10 to 20	75 (22.9)	50 (15.2)
20 to 35	50 (15.2)	25 (7.6)
>35	25 (7.6)	25 (7.6)

- Outlet: Diversions should have stable outlets, either natural or constructed. Site spacing may need to be adjusted for field conditions to use the most suitable areas for water disposal into brush or onto an energy dissipater.

Construction Specifications:

- Install the diversion as soon as the right-of-way has been cleared and graded.

- The waterbars and rolling dips should be built at an angle of 45 to 60 degrees from the centerline.
- The diversion should have a positive grade of 2% minimum.
- For rolling dips the height from channel bottom to the top of the settled ridge shall be 18 inches (0.5 m) and the side slopes of the ridge shall be 2:1 or flatter.

Inspection and Maintenance:

- Inspect after every heavy rainfall for erosion damage.
- Check outlet areas and make timely repairs as needed.

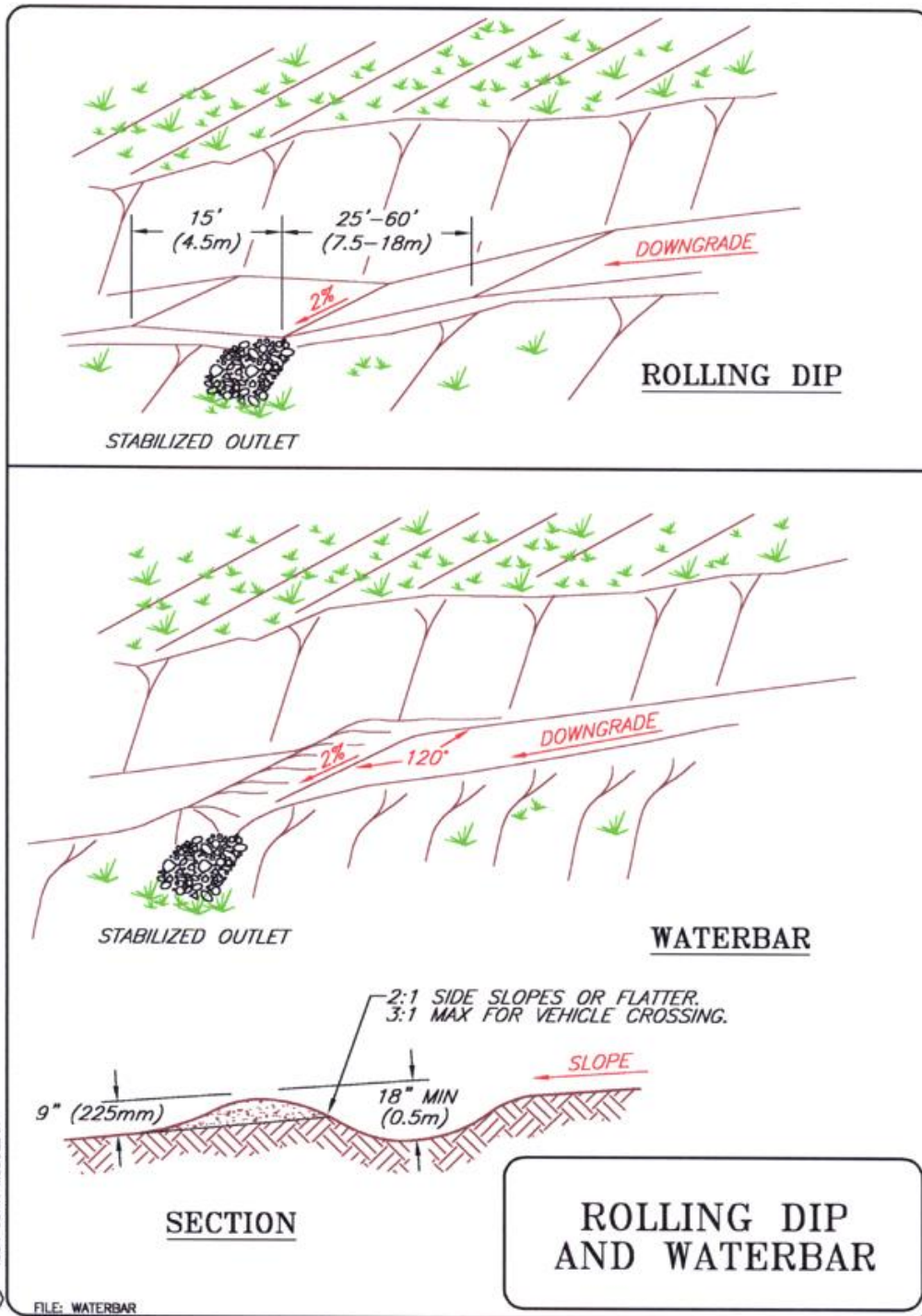

Typical Drawing: Rolling Dip and Waterbar

ENERGY DISSIPATORS

Definition:

An energy dissipater is a structure designed to control erosion at the outlet of a channel or conduit.

Purpose:

To prevent erosion at the outlet of a channel or conduit by reducing the velocity of flow and dissipating the energy.

Conditions Where Practice Applies:

This practice applies where the discharge velocity of a pipe, box culvert, diversion, open channel, or other water conveyance structure exceeds the permissible velocity of the receiving channel or disposal area.

Planning Considerations:

The outlets of channels, conduits, and other structures are points of high erosion potential, because they frequently carry flows at velocities that exceed the allowable limit for the area downstream. To prevent scour and undermining, an outlet stabilization structure is needed to absorb the impact of the flow and reduce the velocity to non-erosive levels. The riprap apron should be extended downstream until stable conditions are reached, even though this may exceed the length calculated for design velocity control. Riprap-stilling basins or plunge pools reduce flow velocity rapidly. They should be considered in lieu of aprons where over falls exit at the ends of pipes or where high flows would require excessive apron length. Consider other energy dissipaters such as concrete impact basins or paved outlet structures where site conditions warrant.

Design Criteria:

The criteria for design of riprap outlets are:

- Capacity: 10-year peak runoff or the design discharge of the water conveyance structure, whichever is greater.
- Apron Size: If the water conveyance structure discharges directly into a defined channel, extend the apron across the channel bottom and up the channel banks to an elevation of 0.5 feet (150 mm) above the maximum tail water depth or to the top of the bank, whichever is less. Determine the maximum allowable velocity for the receiving stream, and design the riprap apron to reduce the flow to this velocity before the flow leaves the apron. Calculate the apron length for velocity control or use the length required to meet stable conditions downstream, whichever is greater.
- Grade: Ensure that the apron has zero grade. There should be no overfall at the end of the apron; that is, the elevation of the top of the apron, at the downstream end, should be the same as the elevation of the bottom of the receiving channel or the adjacent ground if there is no channel.
- Alignment: The apron should be straight throughout its entire length, but if a curve is necessary to align the apron with the receiving stream, locate the curve in the upstream section of riprap.
- Materials: Ensure that riprap consists of a well-graded mixture of stone. Larger stone should predominate, with sufficient smaller sizes to fill the voids between the stones. The diameter of the largest stone size should be no greater than 1.5 times the d_{50} size.
- Thickness: The minimum thickness of riprap shall be 1.5 times the maximum stone diameter.
- Filter: Install geotextile to prevent soil movement through the openings in the riprap.

Learn more techniques to create energy dissipation in lined channels under “Check Dams”.

Construction Specifications:

Filter cloth, when used, must meet design requirements and be properly protected from punching or tearing during installation. Repair any damaged fabric by removing the riprap and placing another piece of filter cloth over the damaged area. All connecting joints should overlap a minimum of 1 foot.

- Riprap may be placed by equipment, but take care to avoid damaging the filter.
- The minimum thickness of the riprap should be 1.5 times the maximum stone diameter.
- Construct the apron on zero grade with no overfall at the end. Make the top of the riprap at the downstream end level with the receiving area or slightly below it.
- Ensure that the apron is properly aligned with the receiving stream.
- Immediately after construction, stabilize all disturbed areas with vegetation.

Inspection and Maintenance:

Inspect riprap outlet structures after heavy rains to see if any erosion around or below the riprap has taken place or if stones have been dislodged. Immediately make all needed repairs to prevent further damage.



YES ▼



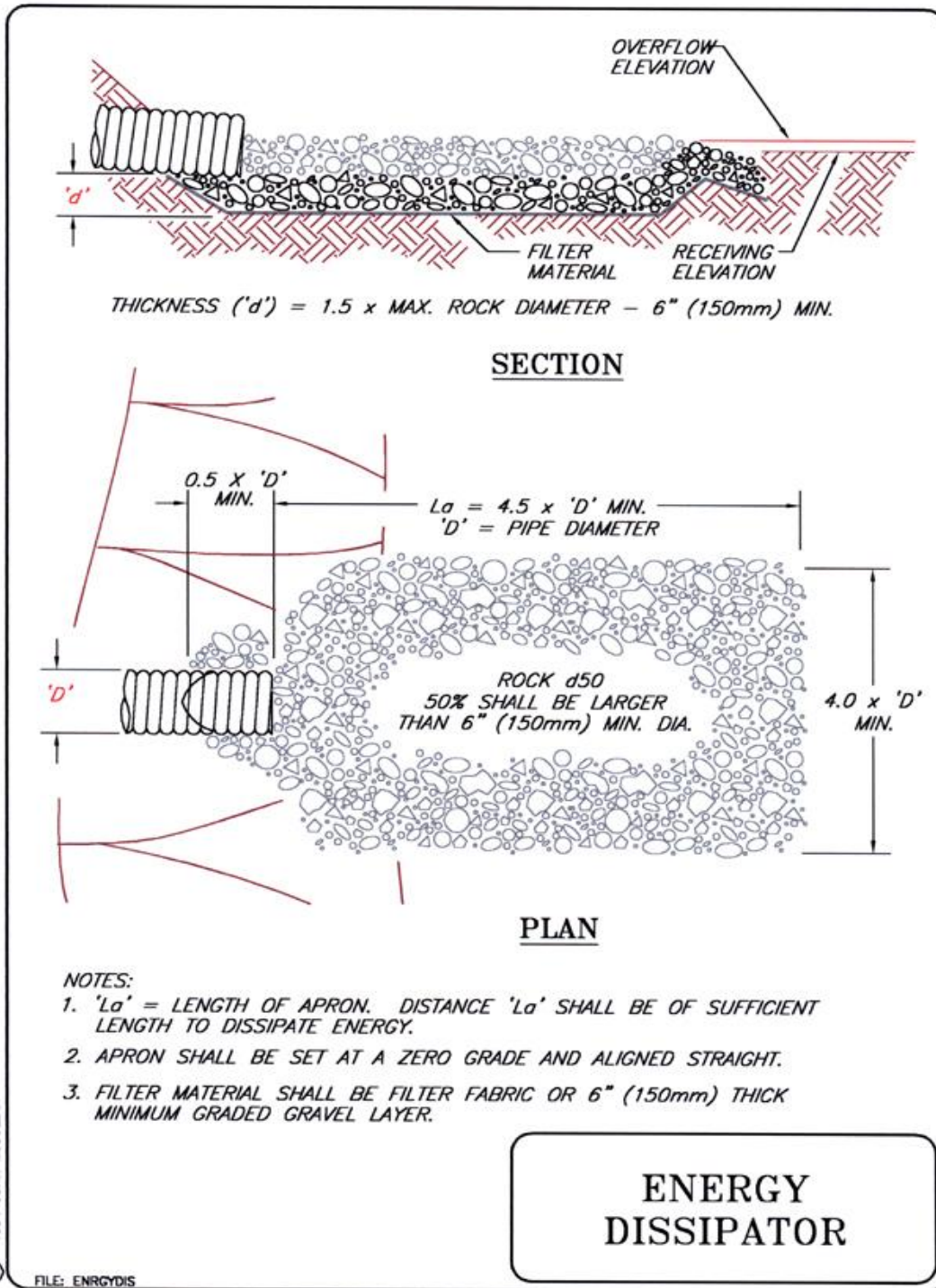

Typical Drawing: Energy Dissipater

CHAPTER 5 EROSION CONTROL BMPs

Erosion control is any practice that protects the soil surfaces and prevents the soil particles from being detached by rainfall or wind. Erosion control, therefore, is a source control that treats the soil as a resource that has value and should be kept in place.

The most efficient and economical method of controlling sheet, rill and raindrop impact erosion is to establish vegetative cover from seed. Vegetation can reduce erosion by more than 90% by protecting the soil from raindrop impact and sheet erosion.

When erosion control BMPs are implemented and maintained, the amount of sediment associated with runoff waters can be dramatically reduced. Whenever possible do erosion control first and sediment control second. Some important points to remember:

- Vegetative cover is the primary erosion control practice.
- Retain existing vegetation by minimizing disturbance and scheduling large land disturbances during periods of expected dry weather.
- Establishing cover immediately after disturbance (staging) is important.
- Temporary erosion control is usually achieved by seeding with fast growing annual grasses and/or protecting the soil with mulch.
- Permanent erosion control usually involves planting perennial grasses, shrubs, and trees.

The selection of the right plant material for the site, choosing the correct mulching technique and proper seedbed preparation are critical for effective erosion control. Surface roughening, contour furrows, and stepped slopes are essential to establish vegetation.

Costs:

Non-structural erosion control practices are generally more cost-effective than sediment control. For example, the cost of temporary seeding one acre would be comparable to the cost of installing 200 LF of silt fence (for a 1-acre drainage) or equivalent to the cost of constructing a temporary sediment trap designed for a one-acre drainage. However, the practice of temporary seeding would probably be more effective while the silt fence and sediment trap will require regular and costly maintenance.

Erosion control is, generally, more cost-effective than sediment control and requires less maintenance and repair.

EROSION CONTROL BLANKETS AND MATS

Definition:

The installation of protective mulch blankets or soil stabilization mats (turf reinforcement mats) to the prepared soil surface of a steep slope, channel or shoreline.

Purpose:

Erosion control blankets are used to temporarily stabilize and protect disturbed soil from raindrop impact and surface erosion, to increase infiltration, decrease compaction and soil crusting, and to conserve soil moisture. Mulching with erosion control blankets will increase the germination rates for grasses and legumes and promote vegetation establishment. Erosion control blankets also protect seeds from birds, reduce desiccation and evaporation by insulating the soil and seed environment.

Some types of erosion control blankets and turf reinforcement mats are specifically designed to stabilize channelized flow areas. These blankets and mats can aid the establishment of vegetation in waterways and increase the maximum permissible velocity of the given channel by reinforcing the soil and vegetation to resist the forces of erosion during runoff events. Stems, roots and rhizomes of the vegetation become intertwined with the mat, reinforcing the vegetation and anchoring the mat.

Conditions Where Practice Applies:

Establishing vegetation in channels or on slopes may require additional measures beyond seeding and straw mulching. Conditions where erosion control blankets and mats are appropriate may include:

- Slopes and disturbed soils where mulch must be anchored and other methods such as, crimping or tackifying are neither feasible nor adequate.
- Steep slopes, generally steeper than 3:1.
- Slopes where erosion hazard is high.
- Critical slopes adjacent to sensitive areas such as streams and wetlands.
- Disturbed soil areas where planting is likely to be slow in providing adequate protective cover.
- Channels with flow exceeding 2-4 ft./sec. (0.6-1 m/sec.).
- In channels that are to be vegetated and where the design flow exceeds the permissible velocity. Allowable velocity, with turf reinforcement mats after vegetative establishment, is up to 10 ft./sec. (3 m/sec).

Specifications:

Erosion control blankets are generally a machine produced mat of organic, biodegradable mulch such as straw, curled wood fiber (excelsior), coconut fiber or a combination thereof, evenly distributed on or between photodegradable polypropylene or biodegradable natural fiber netting.

- Synthetic erosion control blankets are a machine-produced mat of ultraviolet stabilized synthetic fibers and filaments. The nettings and mulch material are stitched to ensure integrity and the blankets are provided in rolls for ease of handling and installation.
- Soil stabilization and turf reinforcement mats are high strength, flexible, machine produced, three dimensional matrix of nylon, polyethylene, polypropylene or polyvinyl chloride that have ultraviolet (UV) stabilizers added to the compounds to ensure endurance and provide ‘permanent vegetation stabilization.’

Planning Considerations:

Erosion control blankets and turf reinforcement matting can be applied to problem areas to supplement nature’s erosion control system (vegetation) in its initial establishment and in providing a safe and ‘natural’ conveyance for high velocity stormwater runoff. These products are being used today in many applications where previously a structural lining or armoring would have been required. ***Care must be taken to choose the type matting which is more appropriate for the specific needs of a project.***

Construction Specifications:

Site Preparation:

- Grade and shape area of installation.
- Remove all rocks, clods, and vegetative or other obstructions so that the installed blankets, or mats will have direct contact with the soil.
- Prepare seedbed by loosening 2-3 inches (50-75 mm) of topsoil above final grade.
- Incorporate amendments, such as lime and fertilizer, into soil according to soil test.

Seeding:

Seed area before blanket installation for erosion control and re-vegetation. Seeding after mat installation is often specified for turf reinforcement application. When seeding prior to blanket installation, all check slots

and other areas disturbed during installation must be reseeded. Where soil filling is specified, seed the matting and the entire disturbed area after installation and prior to filling the mat with soil.

Anchoring:

U-shaped wire staples, metal geotextile stake pins, or triangular wooden stakes can be used to anchor mats to the ground surface. Wire staples should be a minimum of 11 gauge. Metal stake pins should be 3/16 inch (4.8 mm) diameter steel with a 1 1/2 inch (38.1 mm) steel washer at the head of the pin. Wire staples and metal stakes should be driven flush to the soil surface. All anchors should be 6-8 inches (0.2-0.5 m) long and have sufficient ground penetration to resist pullout. Longer anchors may be required for loose soils.

Installation on Slopes:

- Begin at the top of the slope and anchor its blanket in a 6-inch (0.2 m) deep x 6-inch (0.2 m) wide trench. Backfill trench and tamp earth firmly.
- Unroll blanket downslope in the direction of the water flow.
- The edges of adjacent parallel rolls must be overlapped 2-3 inches (51-76 mm) and be stapled every 3 feet (0.9 m).
- When blankets must be spliced, place blankets end over end (shingle style) with 6-inch (0.2 m) overlap. Staple through overlapped area, approximately 12 inches (0.3 m) apart.
- Lay blankets loosely and maintain direct contact with the soil - do not stretch.
- Blankets shall be stapled sufficiently to anchor blanket and maintain contact with the soil. Staples shall be placed down the center and staggered with the staples placed along the edges. Steep slopes, 1:1 to 2:1, require 2 staples per square yard. Moderate slopes, 2:1 to 3:1, require 1-2 staples per square yard (1 staple 3' o. C.). Gentle slopes require 1 staple per square yard.

Installation in channels:

- Dig initial anchor trench 12 inches (0.3 m) deep and 6 inches (0.2 m) wide across the channel at the lower end of the project area.
- Excavate intermittent check slots, 6 inches (0.2 m) deep and 6 inches (0.2 m) wide across the channel at 25-30 foot (7.6-9.1 m) intervals along the channel.
- Cut longitudinal channel anchor slots 4 inches (101 mm) deep and 4 inches (101 mm) wide along each side of the installation to bury edges of matting. Whenever possible extend matting 2-3 inches (51-76 mm) above the crest of channel side slopes.
- Beginning at the downstream end and in the center of the channel, place the initial end of the first roll in the anchor trench and secure with fastening devices at 1-foot (0.3 m) intervals. Note: matting will initially be upside down in anchor trench.
- Position adjacent rolls in anchor trench, overlapping the preceding roll a min. of 3 inches (76 mm).
- Secure these initial ends of mats with anchors at 1-foot (300 mm) intervals.
- Unroll center strip of matting upstream. Stop at next check slot or terminal anchor trench.
- Unroll adjacent mats upstream in similar fashion, maintaining a 3-inch (76 mm) overlap.
- Fold and secure all rolls of matting snugly into all transverse check slots. Lay mat in the bottom of the slot then fold back against itself. Anchor through both layers of mat at 1-inch (25 mm) intervals, then backfill and compact soil.

Inspection and Maintenance:

- All blanket and mats should be inspected periodically following installation.
- Inspect installation after significant rainstorms to check for erosion and undermining.

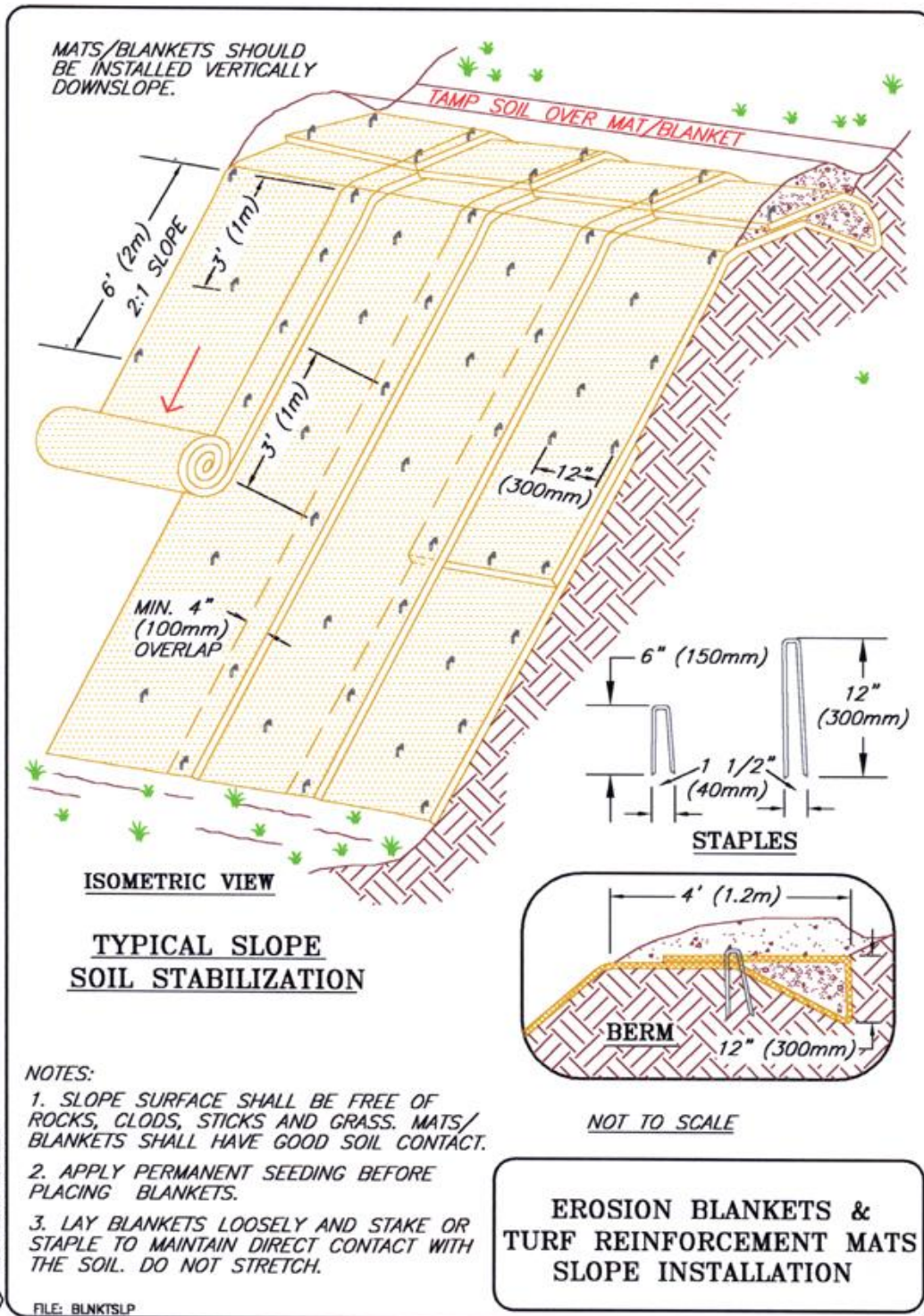

Typical Drawing: Erosion Blankets and Turf Reinforcement Mats Slope Installation

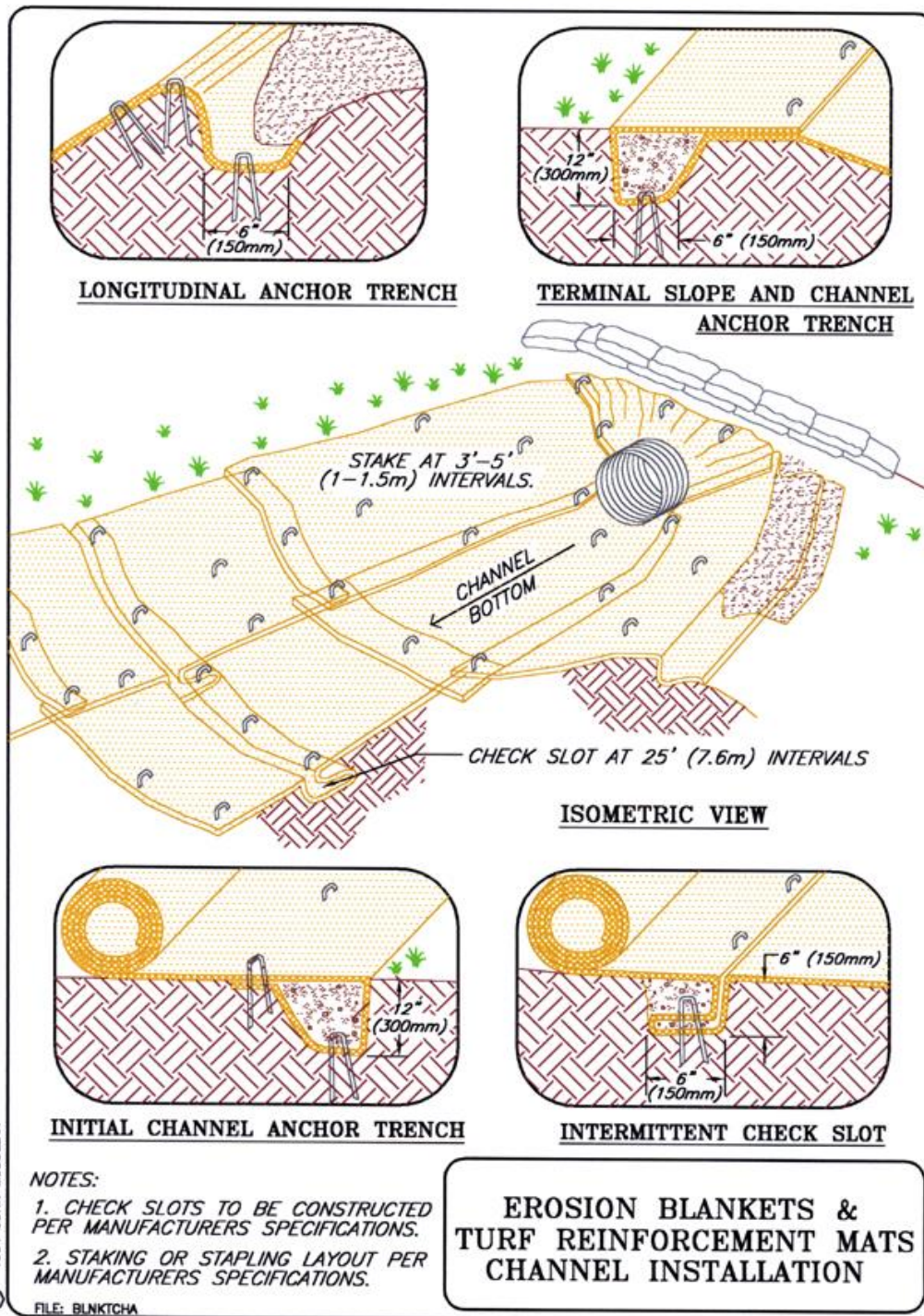

Typical Drawing: Erosion Blankets and Turf Reinforcement Mats Channel Installation

RIPRAP

Definition:

Riprap is a layer of stone designed to protect and stabilize areas subject to erosion.

Purpose:

To protect the soil surface from erosive forces and/or improve stability of soil slopes that are subject to seepage or have poor soil structure. Also used to slow down water flow.

Conditions Where Practice Applies:

Riprap is used for the following applications:

- channel side slopes and bottoms,
- inlets and outlets for culverts, bridges, slope drains, grade stabilization structures, and storm drains,
- streambank and stream grades,
- shorelines subject to wave action.

Planning Considerations:

- Riprap is a versatile, highly erosion-resistant material that can be used effectively in many locations and in a variety of ways to control erosion on construction sites.
- Graded Versus Uniform Riprap: Riprap is classed as either graded or uniform. Graded riprap includes a wide mixture of stone sizes. Uniform riprap consists of stones nearly all the same size.
- Graded riprap is preferred to uniform riprap in most applications because it forms a dense, flexible cover.
- Proper slope selection and surface preparation are essential for successful long term functioning of riprap. Adequate compaction of fill areas and proper use of filter blankets or aggregate foundation is necessary. A pre-constructed type of riprap includes grid pavers, articulated concrete mats, concrete armor units, and interlocking concrete blocks.
- When riprap is used for outlet protection, place the riprap before, or in conjunction with the installation of the structure so that it is in place before the first runoff event.

Design Criteria:

- Gradation: Riprap should be a well-graded mixture with 50% by weight larger than the specified design size.
- Size: The designer should determine the riprap size that will be stable for site conditions. Having determined the design stone size, the designer should then select the size or sizes that equal or exceed riprap gradation commercially available in the area.
- Thickness: Construction techniques, dimensions of the area to be protected, size and gradation of the riprap, the frequency and duration of flow, difficulty and cost of maintenance, and consequence of failure should be considered when determining the thickness of riprap linings. The minimum thickness should be 1.5 times the maximum stone diameter., but in no case less than 6 inches (150 mm).
- Slope Stabilization: Riprap stone for slope stabilization not subject to flowing water or wave action should be sized for stability for the proposed grade. The gradient of the slope to be stabilized should be less than the natural angle of repose of the stone selected. Riprap used for surface stabilization of slopes does not add significant resistance to sliding or slope failure and should not be considered a retaining wall.
- Outlet Protection: Design criteria for sizing stone and determining the dimensions of riprap pads at channel or conduit outlets are presented in: USDA, SCS Field Design Manual; Manual of Standards

for Erosion and Sediment Control Measures-Association of Bay Area Governments and other engineering design manuals.

- **Filter Blanket:** A filter blanket is a layer of material placed between the riprap and the underlying soil to prevent soil movement into or through the riprap. A suitable filter may consist of a well-graded gravel or sand-gravel layer or a synthetic filter fabric manufactured for this purpose. The design of a gravel filter blanket is based on the ratio of particle size in the overlying filter material to that of the base material in accordance with the criteria below. The designed gravel filter blanket may consist of several layers of increasingly large particles from sand to erosion control stone. Filter blankets should always be provided where seepage is significant or where flow velocity and duration of flow or turbulence may cause the underlying soil particles to move through the riprap.

Construction Specifications:

- Before laying riprap and filler, prepare the subgrade to the required lines and grades shown on the plans. Compact any fill required in the subgrade to a density approximating that of the surrounding undisturbed material.
- Overfill depressions with riprap.
- Cut the subgrade sufficiently deep so that the finished grade of the riprap will be at the elevation of the surrounding area. Channels should be excavated sufficiently to allow placement of the riprap in a manner such that the finished inside dimensions and grade of the riprap meet design specifications.
- Place the sand and gravel filter blanket immediately after the ground foundation is prepared. For gravel, spread filter stone in a uniform layer to the specified depth. Where more than one layer of filter material is used, spread the layers with minimal mixing.
- Place the filter fabric directly on the prepared foundation. Overlap the edges by at least 12 inches (300 mm), and space anchor pins every 3 feet (1 m) along the overlap. Bury the upper and lower ends of the cloth a minimum of 12 inches (300 mm) below ground. Take care not to damage the cloth when placing riprap.
- Placement of riprap should follow immediately after placement of the filter. Place riprap so that it forms a dense, well-graded mass of stone with a minimum of voids. Place riprap to its full thickness in one operation.
- Do not place riprap by dumping through chutes or other methods that cause segregation of stone sizes.
- Take care not to dislodge the underlying base or filter when placing the stones.
- The toe of the riprap slope should be keyed to a stable foundation at its base.
- The toe should be excavated to the depth about 1.5 times the design thickness of the riprap and should extend horizontally from the slope.
- The finished slope should be free of pockets of small stone or clusters of large stones. Hand placing may be necessary to achieve the proper distribution of stone sizes to produce a relatively smooth, uniform surface. The finished grade of riprap should be apparent.

Inspection and Maintenance:

Properly designed and installed riprap requires very little maintenance. Riprap should be inspected periodically for scour or dislodged stones. Control of weed and brush growth may be needed in some locations.

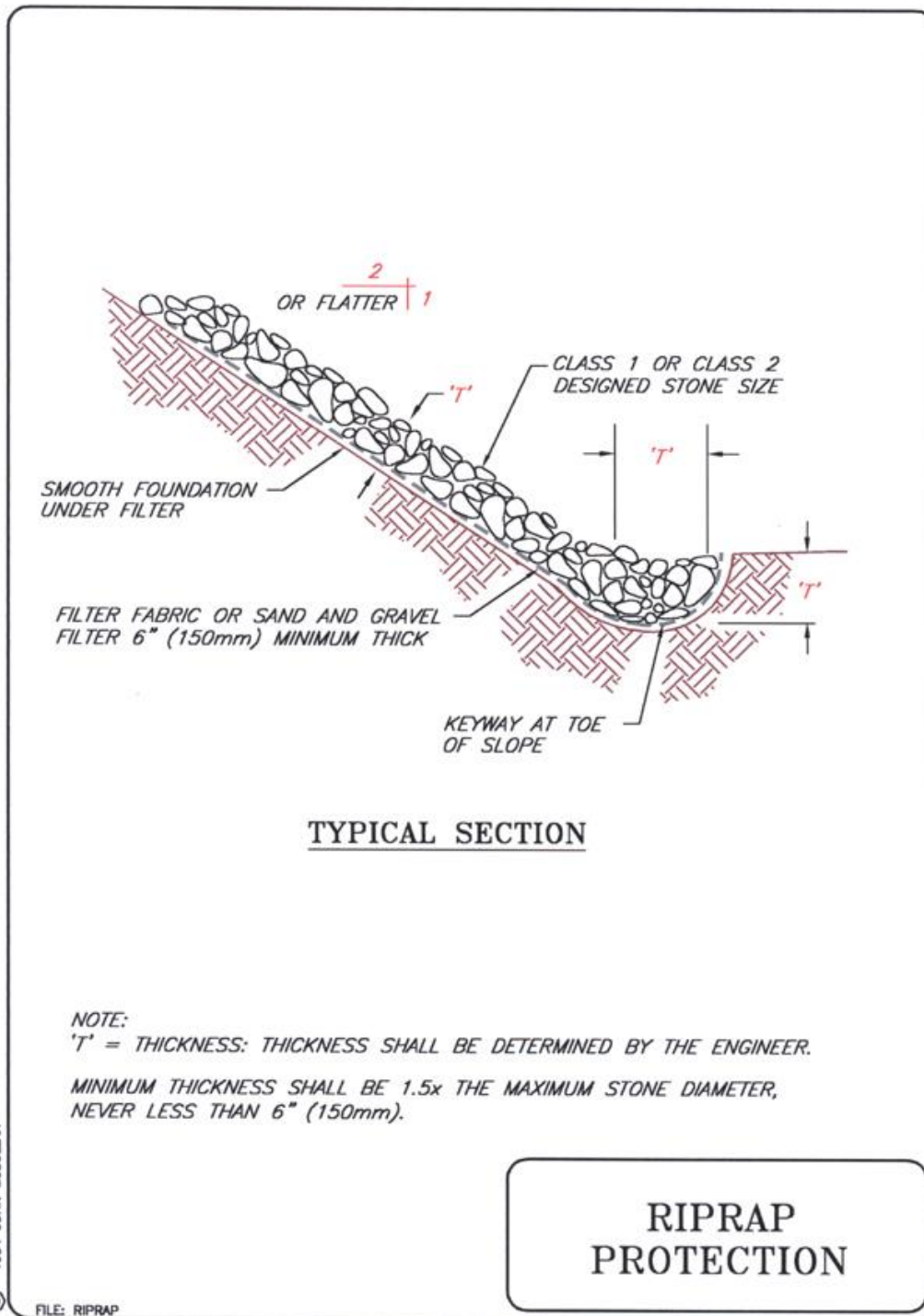

Typical Riprap Protection Detail

Check Dams

Definition:

Small dams constructed across a swale or drainage ditch generally composed of riprap. A sump prior to the dam provides sediment retention.

Purpose:

To reduce the velocity of concentrated flows, reducing erosion of the swale or ditch, and to slow water velocity to allow retention of sediments.

Construction Specifications:

- Check dams can be constructed of rock or pea-gravel filled bags. Provide a deep sump immediately upstream.
- The maximum spacing between the dams shall be such that the toe of the upstream dam is at the same elevation as the top of the downstream dam.
- Rock check dams shall be constructed of appropriately sized rock. Ensure that the center of the dam is lower than the edges. The rock used must be large enough to stay in place given the expected design flow through the channel.

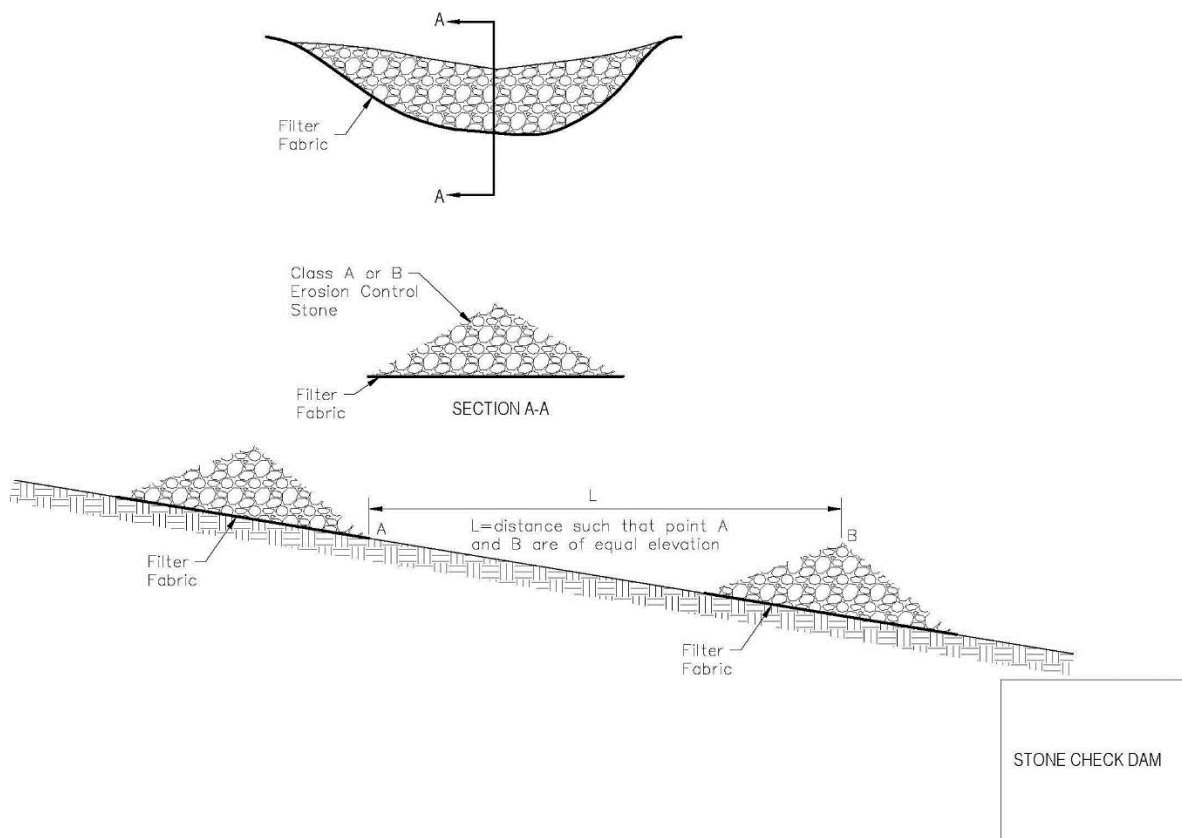

Inspection and Maintenance:

Check dams shall be monitored for performance and sediment accumulation during and after each runoff producing rainfall. Sediment shall be removed when it reaches one half the sump depth. All temporary erosion and sediment control measures shall be removed after final site stabilization is achieved or after the temporary BMPs are no longer needed. Trapped sediment shall be removed or stabilized on site. Disturbed soil areas resulting from removal shall be permanently stabilized.

Cellular Confinement Systems

Definition:

A three-dimensional, honeycomb earth-retaining structure used to mechanically stabilize the surface of earth and fill slopes.

Purpose:

Cellular Confinement System (CCS) is a permanent erosion control practice intended to stabilize infill materials for slope and channel protection, load support, and earth retention applications. The expandable panels create a cellular system that confines topsoil infill, protects and reinforces the plant's root zone, and permits natural subsurface drainage. The honeycomb shaped cells encapsulate and prevent erosion of the infill material. The cellular confinement systems are used for:

- Revetments - filling the cells with topsoil or rock can provide an alternative to hard armor revetment systems.
- Erosion control on steep slopes - cells can be infilled with soil and vegetated. Slopes as steep as 1:1 can be treated with cellular confinement systems. Application on steep slopes may require tendons for system stability and security against sliding.
- Flexible channel lining systems, either vegetated or rock filled.
- Road stabilization - cells confine and reinforce select fill materials, thereby increasing load-bearing capacities. Creates a porous pavement system with aggregate or topsoil/vegetation infill.

Construction Specifications:

- Site Preparation:
The surface of the slope should be leveled, with stones and debris removed. Following excavation and fill placement operations, shape and compact the subgrade surfaces to the designed elevations and grades. Excavate the area so that when cellular confinement systems are installed, the top of the section is flush with or slightly lower than the adjacent terrain or final grade. Remove unstable subgrade soils when required and install geotextile underlayer if specified.
- Installation:
Anchor the cellular confinement system sections at the top of the slope across a 2-4 foot (0.6-1 m) ledge. Expand and stretch the cellular confinement system down the slopes. Typically, every other cell across the top section is anchored with J-pins or other suitable anchor devices. This anchoring pattern is repeated every 6 feet (2 m) down the slope. The cells should be anchored securely in order to prevent deformation of the panel while backfilling. Depending on the slope angle and fill soils involved, intermediate anchorage will be necessary on some interior cells in order to limit sideways deformation, insure stability and avoid overloading the upper sections. Additional panels are abutted together and joined with staples, hog rings or other suitable fasteners.
- Infill Placement:
Place the fill material in the expanded cells with suitable equipment such as a back-hoe, front-end loader or conveyer. Limit drop height to 3 feet (1 m). On steep slopes, infill from the crest to the toe to prevent displacement and deformation of the cellular confinement system.

Inspection and Maintenance:

- Inspect slope periodically and after significant rainstorms to check for erosion.
- If vegetation has not been established, fertilize and reseed damaged and sparse areas immediately.

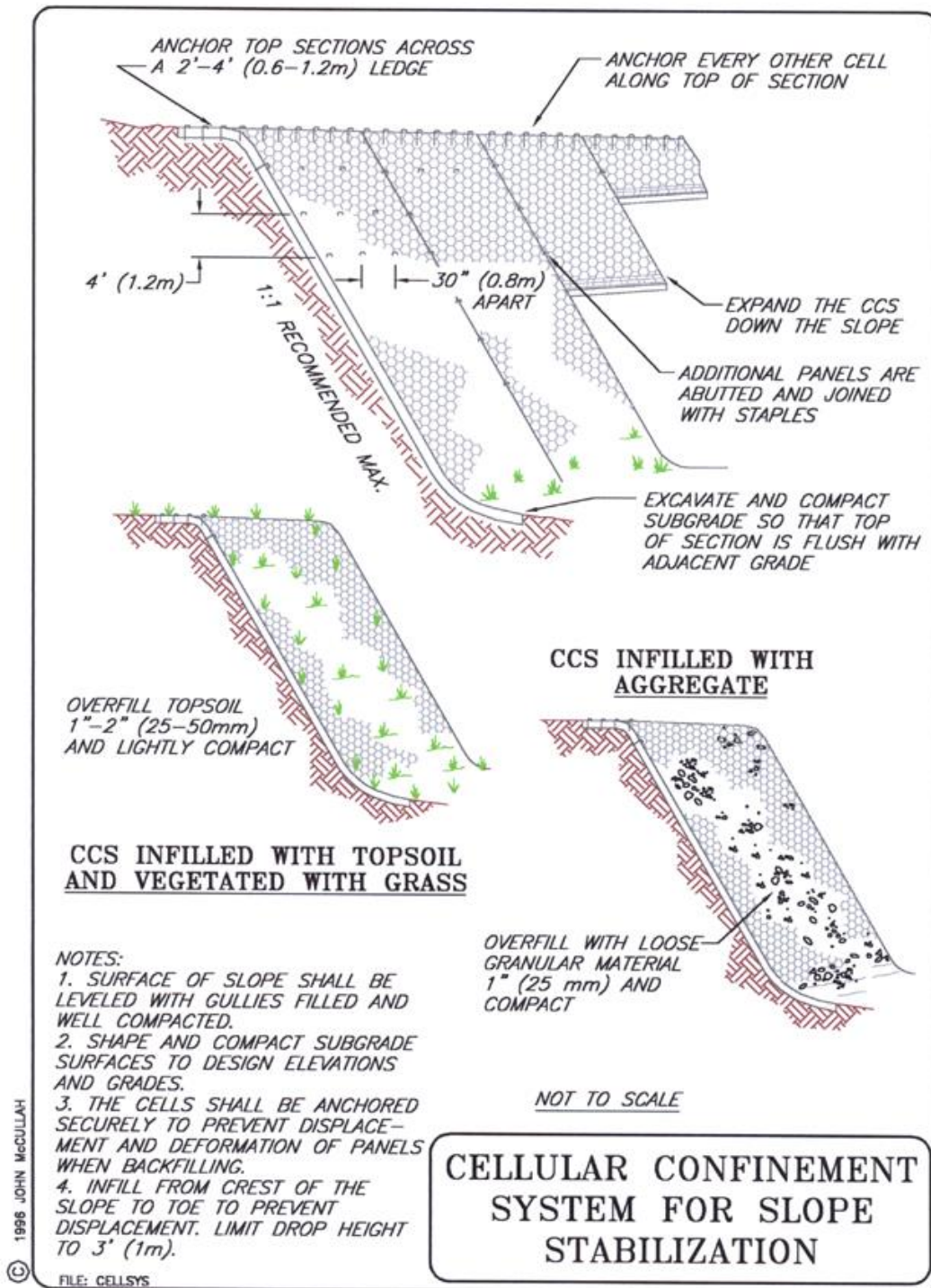

Typical Drawing: Cellular Confinement Systems

CHAPTER 6 SEDIMENT CONTROL BMPs

Sedimentation is the deposition of soil particles that have been transported by water or wind. The amount of sediment produced during construction is directly proportional to the degree and effectiveness of erosion control practices implemented. The quantity and size of the particles transported increases with the velocity of the runoff.

Sediment control is used to keep sediment, the product of erosion, on-site. Sediment control involves the construction of structures that allow sediment to settle out of suspension. Sediment control structures, therefore, require frequent inspection and maintenance.

Generally, sediment is retained on-site by two methods:

1. slowing runoff velocities, as they flow through an area, sufficiently so that sediment cannot be transported, and
2. impounding sediment-laden runoff for a period of time so that the soil particles settle out.

Sediment controls are not filters. Practices referred to as "sediment filtering" actually work by slowing velocities and allowing sediment impoundment to de-water in a very slow and controlled manner. For effective sediment control planning and design, materials such as geotextiles, silt fences, and straw bales should be considered for their ability to impound water and slow runoff velocities, not for their ability to "filter" sediment.

Effective sediment control involves ponding sediment-laden runoff long enough for the soil particles to settle out of suspension. Reducing runoff velocities will also reduce sediment transport and thereby help retain sediment on-site.

Structural sediment control can be divided into three general types;

- 1) sediment basins,
- 2) sediment traps, and
- 3) sediment barriers.

Temporary Sediment Traps, Excavated Sediment Traps, & Excavated Storm Drain Inlets

Definition

Temporary traps designed to trap sediment from small contributing areas during construction. These traps typically require less design work and are inexpensive to construct.

Design Criteria

Temporary Sediment Traps are recommended for disturbed drainage areas less than 5 ac (2 ha). A typical Sediment Trap designed to handle .5 inches (12.7 mm) of runoff over a 24-hour period would require a settling zone capacity of 67 yd³ / ac (130 m³ / ha) of contributing drainage area and a sediment storage capacity of 33 yd³ / ac (65 m³ / ha) of drainage area.

Excavated Sediment Traps require less rigorous design work, are smaller in size and they are easier to construct; therefore, a preferable alternative is to sub-divide large projects into smaller subareas (less than 5 ac) and utilize numerous sediment traps. Multiple traps and / or additional volume may be required to accommodate site specific rainfall and soil conditions. This approach may facilitate phased construction along relatively narrow highway ROW.

Excavated Storm Drain Inlets are small excavated sediment traps located at storm drain inlets are effective as part of phased construction. The design capacity of excavated inlet sediment traps shall be 67 yd³ / acre

(1800 ft³ / ac) of contributing drainage area. These excavations are temporary and they are not very effective for trapping small particles (silt and clay) and they should not be used where runoff velocities are high.

Construction Specifications

- Sediment traps should have a controlled overflow such as a riprap outlet.
- Typically, a sediment barrier such as silt fencing should be located below the outlet.
- A temporary diversion berm should direct flow into the trap.

Inspection and Maintenance

- Inspect after each rain.
- Likely, sediment will need to be removed after each rain.
- Confirm that the outlet is stable.

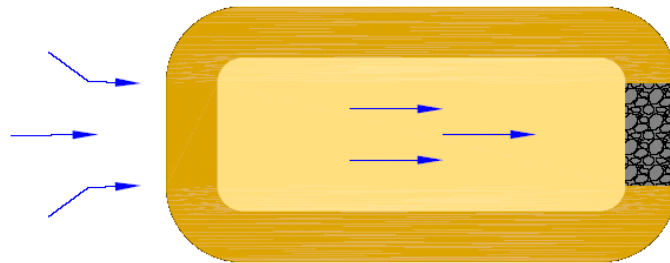
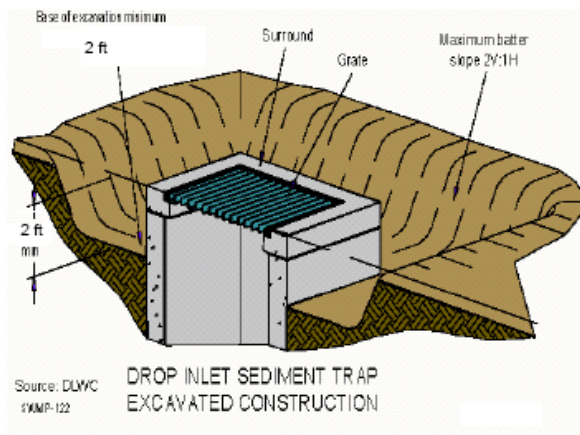

EXCAVATED SEDIMENT TRAP (TOP VIEW)

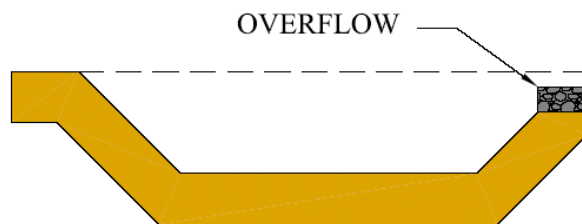

EXCAVATED SEDIMENT TRAP (SIDE VIEW)

DESIGN=67 CU. YDS PER ACRE CONTRIBUTING AREA

TEMPORARY SEDIMENT BASIN

Definition:

A temporary sediment basin is a pond created by excavation in construction of an embankment and designed to retain or detain runoff sufficiently to allow excess sediment to settle.

Purpose:

The temporary sediment basin is intended to collect and store sediment from sites that are cleared and/or graded during construction or for extended periods of time before permanent vegetation is re-established or before permanent drainage structures are completed. It is intended to trap sediment before it leaves the construction site. The basin is temporary, with a design life of 12 to 18 months, and is to be maintained until the site area is permanently stabilized.

Design Considerations:

- Sediment basins can trap 70-80 percent of the sediment which flows into them if designed and constructed appropriately. This design requires a runoff detention time of 24-40 hours. The sediment basin designed according to the criteria in this manual is only practically effective in removing sediment down to the medium silt size. Sediment-laden runoff with smaller size fractions, fine silts and clay, will likely pass *untreated* through the basin. Sediment ponds may be capable of trapping smaller soil particles if additional detention time is provided. Chemical flocculants such as polyacrylamide may also be effective. There are inherent problems associated with constructing basins large enough to pond all the sediment-laden runoff long enough to allow all of the fine soil particles to settle out. Therefore, sediment basins must be used in conjunction with other erosion control practices in order to increase effectiveness and trap efficiently.
- Sediment basins should be located where failure of the embankment would not cause loss of life or property damage. A good location is where a post construction detention basin is proposed.

Design Criteria:

- Design the basin to capture runoff from a 2-year, 24-hour storm.
- A detention time of 24-40 hours is required to allow 70-80 percent of the sediment to settle.
- Use a subsurface drain and/or a solid riser pipe with sufficient dewatering holes to provide sufficient detention time. A perforated riser with a filter fabric and/or gravel jacket may provide sufficient detention time for basins draining up to 10 acres (4.05 ha). Determine the sediment basin volume. The sediment basin volume consists of two zones:
 - 1) A sediment storage zone at least 1 foot (0.3 m) in depth.
 - 2) A settling zone at least 2 feet (0.6 m) in depth.

The settling zone volume is determined by the following equation:

$$V = 1.2(SD)Q/V_{SED}$$

Q = design inflow based on the peak discharge from a specified design storm (e.g., a 2-year, 24-hour duration design storm event) from the tributary drainage area as computed using the methods required by the local flood control agency. Provide a minimum 67 yd³ (51.2 m³) of settling volume per acre (0.4 ha) of drainage if a design storm is not specified.

V/SED = the settling velocity of the design soil particle. The design soil particle chosen is medium silt (0.02 mm). This has a settling velocity (V/SED) of 0.00096 ft./sec. (.024 mm/sec.) As a general rule, it

will not be necessary to design for a particle of size less than 0.02 mm, especially since the surface area requirement increases dramatically for smaller particle sizes. For example, a design particle of 0.01 mm requires about three times the surface area of 0.02 mm. Note also that choosing V_{SED} of 0.00096 ft./sec (.024 mm/sec.) equates to a surface area (SA) of 1250 ft² (116.1 m²) per cfs of inflow.

SD = settling depth, which should be at least 2 feet (0.6 m), and no shallower than the average distance from the inlet to the outlet of the pond (L) divided by 200 (i.e. $SD > L/200$).

The total sediment basin volume and dimensions are determined as outlined below:

- Determine the basin geometry for the sediment storage volume calculated above using a minimum of 1 foot (0.3 m). depth and 3:1 side slopes from the bottom of the basin. Note: the basin bottom is level.
- Extend the basin side slopes (at 3:1 max.) as necessary to obtain the settling zone volume as determined above.
- Adjust the geometry of the basin to effectively combine the settling zone volume and sediment storage volumes while preserving the depth and side slope criteria.
- Provide an emergency spillway with a crest elevation one foot above the tip of the riser pipe.
- The ratio between the basin length and width of the pond should either be greater than 6:1, or baffles should be installed to prevent short-circuiting.
- The length to settling depth ratio (L/SD) should be less than 200.

Construction Specifications:

- Construct the basin by excavating or building an embankment before any clearing or grading work begins.
- A cut-off trench shall be excavated along the centerline of the earth fill embankments. The minimum depth shall be 2 feet (0.6 m). The cut-off trench shall extend up both abutments to the riser crest elevation.
- Fill material for the embankment should be clean mineral soil free of roots, woody vegetation, oversized stones, rocks or other objectionable material.
- Fill material shall be placed in 6 inch (0.2 m) lifts, continuous layers over the entire length of the fill. Compacting shall be obtained by routing the hauling equipment over the fill so that the entire surface of each layer of the fill is traversed by at least one wheel or tread track of the equipment, or by the use of a compactor.
- The embankment should be constructed to an elevation of 10 percent higher than the design height to allow for settlement if compacting is achieved with hauling equipment. If compactors are used for compacting, the overbuild may be reduced to not less than 5 percent.
- The emergency spillway shall not be installed in fill. Elevations, design width, and entrance and exit channel slopes are critical to the successful operation of the emergency spillway.

Inspection and Maintenance:

- Inspect weekly and after each rain.
- All damages caused by soil erosion or construction equipment shall be repaired before the end of each working day.
- Remove sediment when the sediment storage zone is half full. This sediment shall be placed in such a manner that it will not erode from the site. The sediment shall not be deposited downstream from the embankment or in or adjacent to a stream or floodplain.

- When temporary structures have served their intended purpose and the contributing drainage area has been properly stabilized, the embankment and resulting sediment deposit shall be leveled or otherwise disposed of in accordance with the approved erosion and sediment control plan.

Skimmer Outlet:

The skimmer maximizes the use of the volume and surface area of the basin by regulating the flow of water out of the basin, such that it maintains a pool of water that promotes sedimentation. The skimmer does not increase sediment-trapping efficiency in a way that allows the size of the basin to be reduced. The only way for a basin to be effective is for the basin to fill quickly, because the sediment can fall out of suspension only when the pond is full of water. Conventional basins with perforated risers or stone outlets frequently do not fill because the outlet structures do not adequately regulate the outflow. The skimmer drains the basin slowly over several days, and at a constant rate to maximize sedimentation. Instead of draining the basin from the bottom, and releasing the runoff containing the most sediment, the skimmer releases the least polluted water from near the surface.

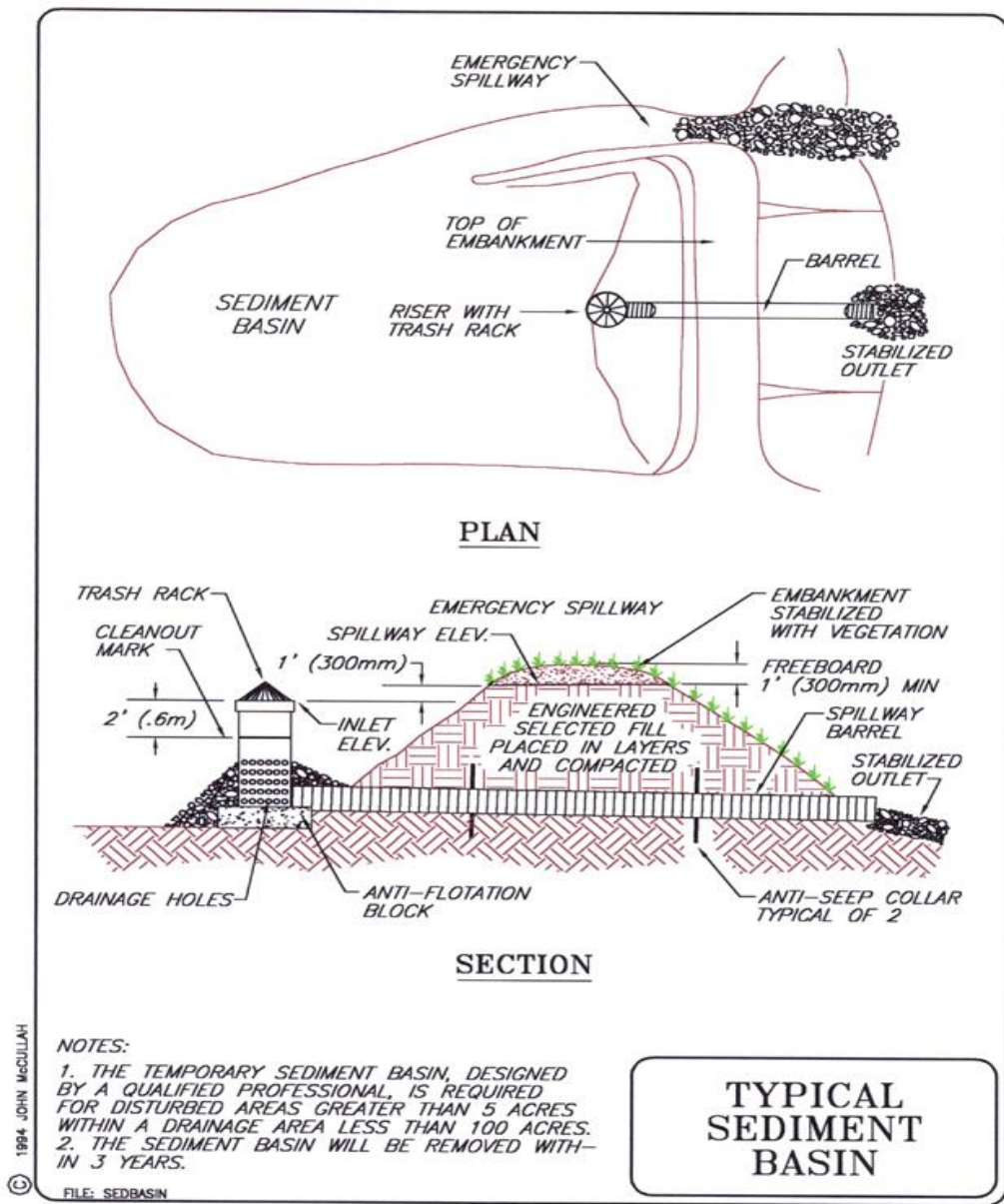

Typical Drawing: Sediment Basin

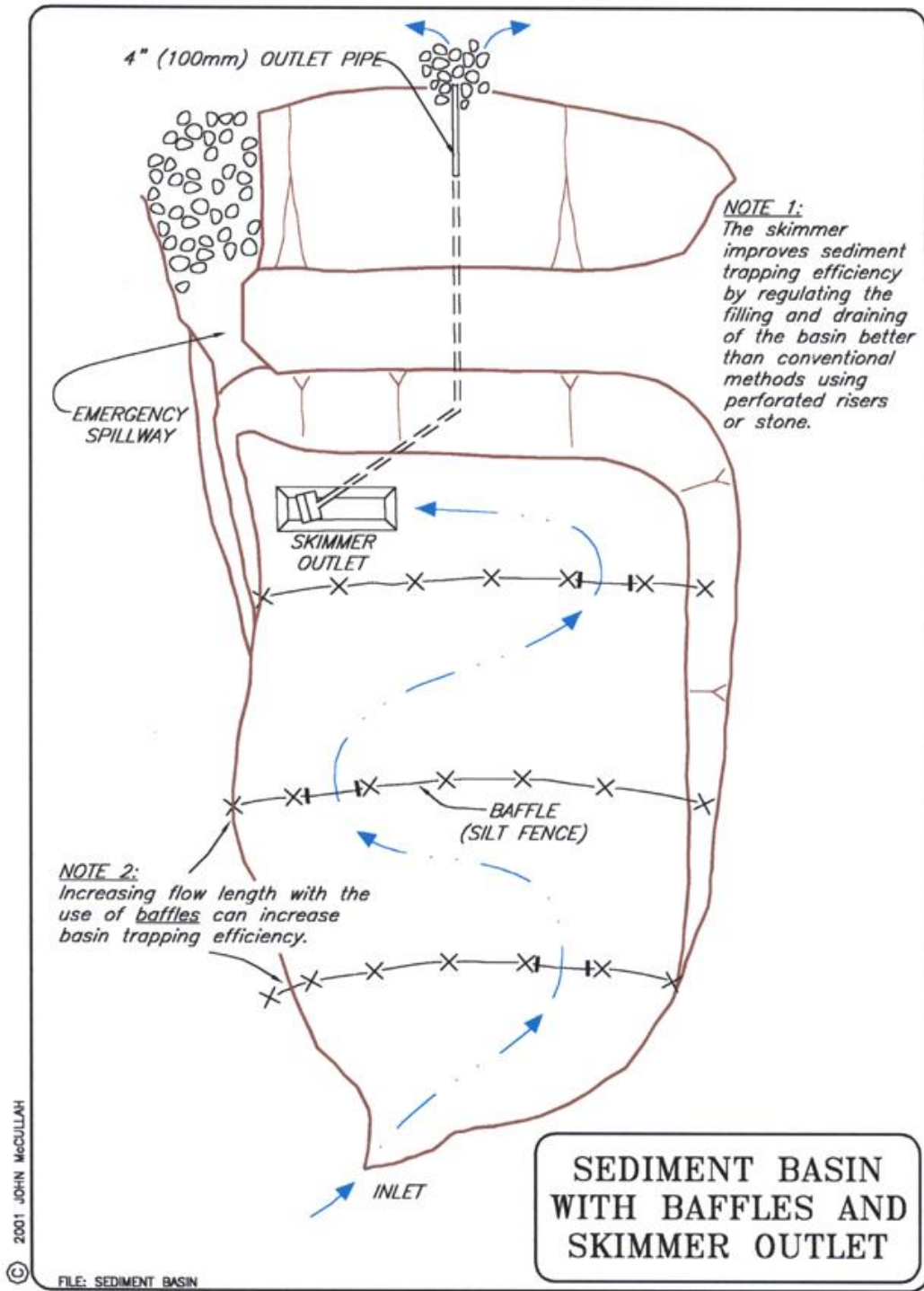

Typical Drawing: Sediment Basin with Baffles and Skimmer Outlet

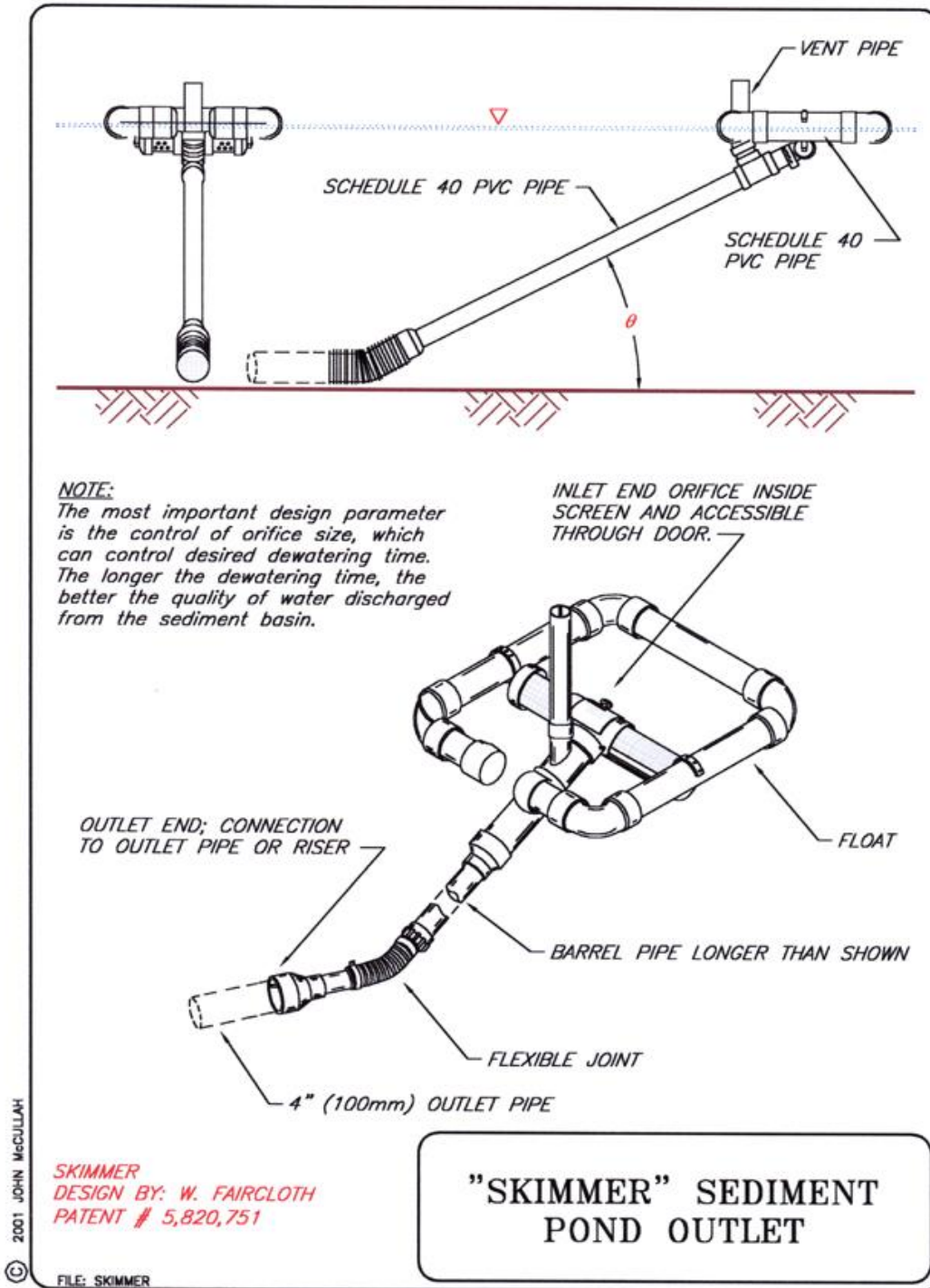

Typical Drawing: "Skimmer" Sediment Pond Outlet

Note: Large Marlee Brand Skimmers are not to be used in North Augusta due to failures observed.

BRUSH BARRIER

Definition:

A brush barrier is generally constructed of the vegetative material cleared from the site and often pushed to the permitted clearing limits into a windrow. The brush barrier may be faced with wire with silt fence attached.

Purpose:

A brush barrier is a sediment control practice that is extremely effective due to the inherent strength of the windrowed material (often containing heavy logs and stumps). As with other sediment controls, proper placing is important to success.

Design Considerations:

- Brush Barriers are often 3-7 feet in height.
- They should be installed on the contour
- As an improvement, wire may be attached to the face if the barrier with filter fabric keyed into the soil and fastened to the wire. With large heavy barriers, an additional section of filter fabric may be installed above the first. This creates the effect of a sediment trap. While silt fence should be cleaned after the accumulation of 9" of sediment, a well-constructed brush barrier could hold 1-2 feet of sediment accumulation. This accumulation should be removed at project completion.
- Upon removal of the wire, fabric, and accumulated sediment, the barrier may be left in place to decompose.

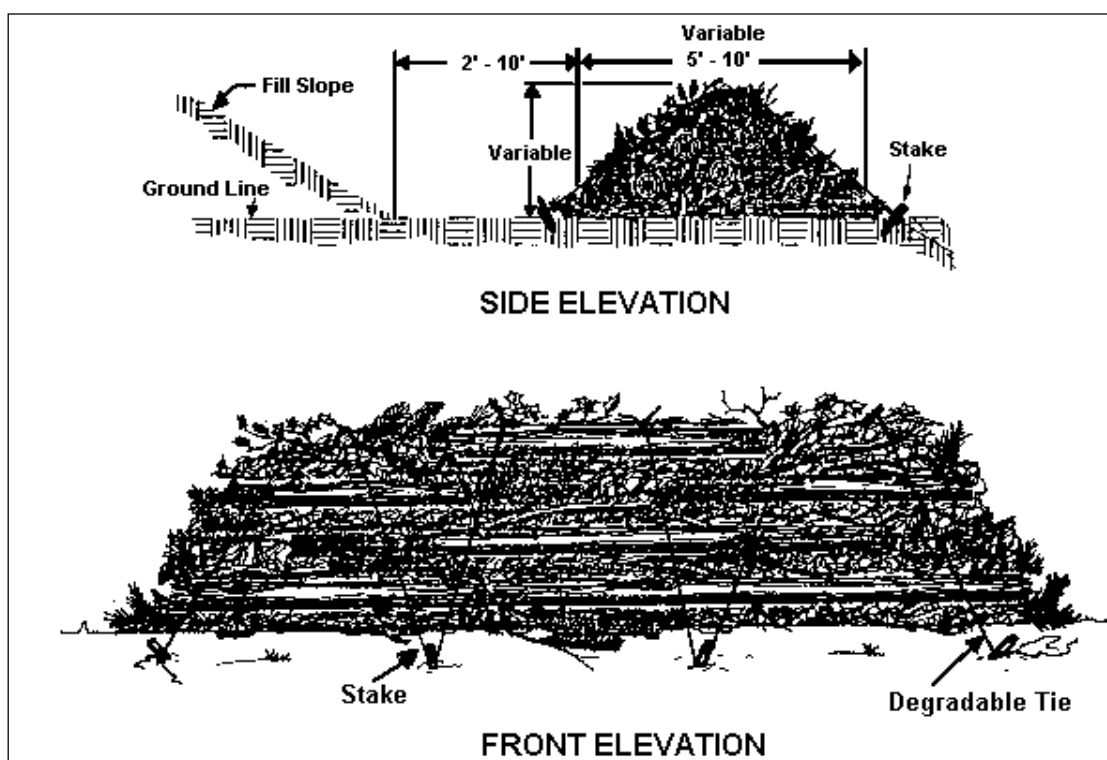

SOURCE: Smoot, J. L., T. D. Moore, J. H. Deatherage, and B. A. Tschantz. 1992. *Reducing Nonpoint Source Water Pollution by Preventing Soil Erosion And Controlling Sedimentation on Construction Sites.*

Inspection and maintenance:

Periodic inspections to identify excess sedimentation and torn fabric are important. New fabric may be installed over the damaged portions.

SILT FENCE

Definition:

A silt fence is a temporary sediment barrier consisting of filter fabric entrenched into the soil and attached to supporting posts. Silt fence installed with a trencher or by slicing is the most effective installation method to ensure against common silt fence failures.

Purpose:

Silt fence is a sediment control practice. Silt fence is intended to be installed where sediment-laden water can pond, thus allowing the sediment to fall out of suspension and separate from the runoff. It is not intended to be an erosion control practice. Improperly applied or installed silt fence will increase erosion. Reasons for the high failure rate of improperly designed and installed silt fence include:

Causes of silt fence failure:

- Improper placement on the site;
- Allowing excessive drainage area to the silt fence structure;
- Shallow trenches with little or no soil compaction;
- Inadequate attachment to posts;
- Failure to maintain the silt fence after installation;
- Installing silt fence along property boundaries producing "concentrated" runoff.



Failure to trench in silt fence

Silt fence is successful where:

- non-concentrated sheet flow will occur;
- protection of adjacent property, wetlands, streams or other waters is required;
- the size of the drainage area is no more than 1/4 acre per 100 linear feet of silt fence;
- the maximum flow path length above the barrier is 100 feet (30.5 m);
- the maximum slope gradient above the barrier is 2:1, or less than or equal to 6%
- Slurry flow rate through the fence is less than or equal to 10 gallons per min per foot (gpm/ft.) or 0.3 cubic feet per second (cfs)
- small swales are carrying silt where the slope is less than 2%
- no practice other than a silt fence is feasible

% Land Slope	Maximum Slope Length Behind Fence
<2	100
2 – 5	75
5 – 10	50
10 – 20	25
>20	15

Silt Fence should not be used where it runs:

- across slopes, even on contour;
- around the perimeter of the construction site, **unless J-hooks and/or 'smiles' are used**. Long continuous runs of silt fence down-sloping will divert and concentrate sediment laden runoff and almost certainly result in failure;

J-hooks or 'smiles' are preferable to linear installations. A good "rule of thumb" is to drain no more than 1/3 acre of disturbed area into each discrete J-hook or 'smile' segment. Once J-hooks are installed, make sure to maintain them by removing the sediment as necessary to keep them working properly and to



prevent overtopping.

Silt fence must only be installed where water can pond. When placed off contour, silt fence will effectively divert runoff, if that is desired.

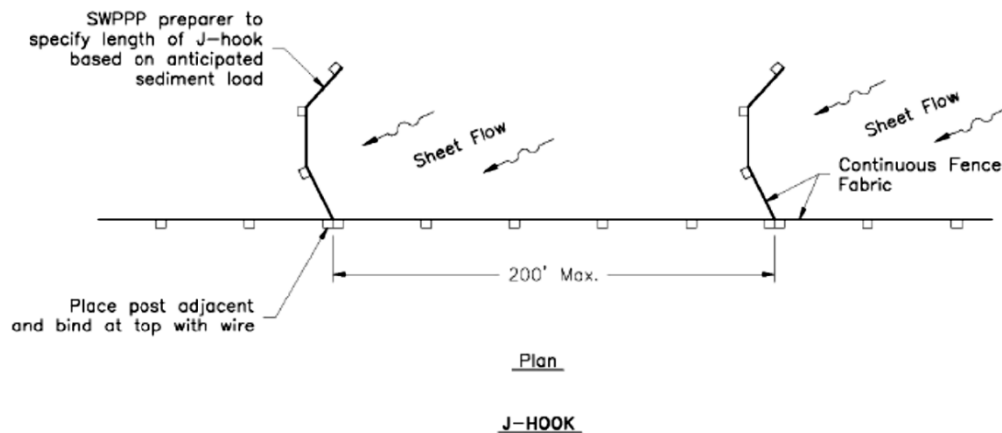

City of North Augusta Approved - Types of Silt Fence

Type A: Fence with fabric that is 36" wide attached to steel posts (or wood posts at least 1½ inch in diameter) spaced no more than 6' a part. This type can be used on projects that are minor, residential home sites, or small commercial developments where stabilization will be achieved within 6 months. This type works well on individual lots with slopes heights that are less than 10 feet.

Type C: Fence with fabric that is 36” wide attached to steel posts spaced no more than 6’ apart with wire reinforcement. The wire reinforcement is necessary because this fabric allows almost three times the flow rate as a Type A silt fence. Type C silt fence shall be used where runoff flows or velocities are particularly high or where slopes exceed a vertical height of 10 feet.

C-POP (Polypropylene On Polypropylene) Silt Fence is a unique silt fence system designed as an alternative to Type C Silt Fence (steel posts with wire reinforcement). This silt fence system is designed to be used as a temporary sediment barrier structure for use in areas where runoff flows or velocities are particularly high or where slopes exceed a vertical height of 10 feet or other situations where high performance erosion control is warranted. If fabric becomes detached from wooden posts, always replace with steel posts. If fabric becomes detached and damaged, replace fence.



C-Pop problems



From factory, and installer didn't realize problem.

Posts

Design Considerations:

Design specifications (with calculation formulas) can be found in Appendix B: Section I.5 Silt Fence Design Aid (SCDOT).

Typical silt fence specifications were written 25 years ago and have changed little since. Some states have recognized some of the inherent problems, such as inadequate trench depth, and implemented minor changes to improve efficacy. Time and experience has shown that the outdated construction specifications, combined with the **improper application and incorrect installation of silt fence, has resulted in it being one of the most ineffective storm water pollution controls in use except for possibly hay bales.**



During the most erosive storm events the silt particles, carried by the sediment-laden runoff, actually plug up the fabrics pore openings. That is how the fabric prevents the discharge of silt. However, the fabric, if properly installed and anchored, will then pond water and sediment can begin to fall out of suspension. The silt fence will have tremendous pressure exerted upon it. Failure will occur if too much water runoff is directed to the fence, if the stakes are not of sufficient strength to support the tremendous forces or, most importantly, the fence is not keyed deeply into a trench (or sliced) and compacted such that runoff cannot go under or around the fence.

The silt fence design aid (Appendix B) applies to silt fences placed in areas down slope from disturbed areas where they serve to retard flow and cause settling. The two conditions that must be met for satisfactory design of a silt fence are: (1) trapping efficiency must meet the desired level of control, and (2) overtopping of the fence must not occur.

Some general design considerations include:

- determine what kind of runoff, and how much, is coming onto the site; too much volume of water per silt fence area means failure will happen;
- determine where and how the total volume is going to exit; total drainage area is the prime consideration of silt fence quantity, not necessarily slope;
- soil type can play a role in the placement and quantity requirements; sandy soils might require more silt fence per area to contain the volume of potential sediment; clay soils might need fewer fences because the volume of potential sediment loss is less, although the volume of water might be greater because clay soils allow less rainfall infiltration;
- type, size and spacing of fence posts; wood **posts are less sturdy** except on flat lots or C-POP; steel t-posts weighing at least 1.25 lbs. per ft. are preferred as they can be driven 24 inches into compacted soil which is necessary to hold a horizontal load 18 inches high. Also they can be recycled and used repetitively. Finally, improper spacing of posts causes failures; **a minimum of 6-foot spacing is required in North Augusta.**
- fabric required for each application must be determined by the design engineer and listed on the site plan. For projects located in North Augusta, the grab tensile strength minimum is 90 lb. and the Mullen Burst Strength minimum is 190 psi.
- along stream/wetland buffers and other sensitive areas, two rows of Type C silt fence

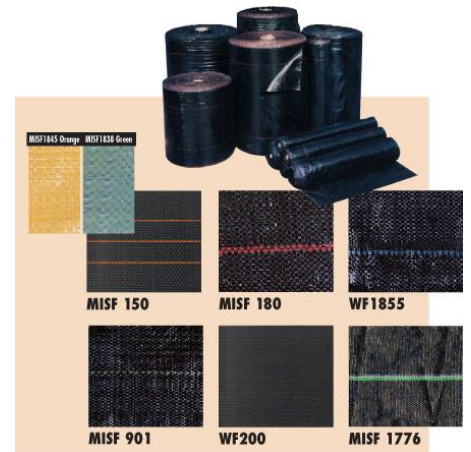

type of fabric matters

(photo: padlockoutlet.com)

The following table with the appropriate values and methods for the specific location at the site (provided by design engineer) is required on site plans.

FABRIC PROPERTIES	VALUES	TEST METHOD
GRAB TENSILE STRENGTH		
MULLEN BURST STRENGTH		
SLURRY FLOW RATE		
EQUIVALENT OPENING SIZE		
ULTRAVIOLET RADIATION STABILITY		

Installing a silt trap at the fence line is helpful to allow the fence to perform longer. The detail below explains the practice.

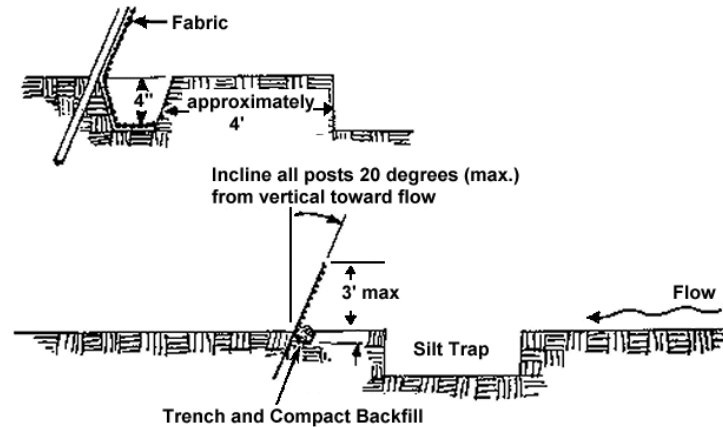

The “life” of silt fence may be increased by installation of a **silt trap**.

Construction Specifications:

- Silt fences have a useful life of one season. Their principal mode of action is to slow and pond the water and allow soil particles to settle. Silt fence is not designed to withstand high heads of water, and therefore should be located where only shallow pools can form. Their use is limited to situations in which sheet or overland flows are expected.
- Install silt fence material into a trench, 4” wide and at least 6” deep, with vertical sides. A preferred installation technique involves static slicing with an implement such as the "Tommy Silt Fence Machine" or equivalent. The trench must be backfilled and compacted.
- Install silt fences with 'smiles' or J-hooks to reduce the drainage area that any segment will impound
- Silt fences placed at the toe of a slope shall be set at least **6 feet (1.8 m) from the toe** in order to increase ponding volume.
- The soil should be sliced and the fabric mechanically installed into the soil.
- The height of a silt fence shall be 36 inches (0.9 m). Storage height and ponding height shall never exceed 18 inches (0.5 m).
- The ends of the fence should be turned uphill as directed by the design engineer.
- Steel support posts that are properly spaced and driven into compacted soil are placed on the down-stream side of the fabric.
- Post spacing shall not exceed 6 feet (1.8 m).
- The filter fabric is wire-tied directly to the posts with three diagonal ties.
- Fabric type is determined by the design engineer and specified on the site plan.
- Double row silt fence must be spaced 8-10 feet apart in all applications with the first row at the toe of the slope located (at a minimum) 6 feet from toe. **PLAN accordingly during design phase.**
- When adding mulch berms for added protection, the berm must be placed at a minimum 3 feet from the silt fence to prevent it from acting as a ramp for runoff to overtop silt fence.

The slicing method has the capability to turn in a short distance, thus properly installing silt fence where needed. Turning enables upturns on the ends of silt fence runs, maneuvering around obstacles on construction sites, protection along property lines, and following the existing site contours.

Inspection and Maintenance:

- Inspect fence for proper installation and compaction by **pulling up on the fence while kicking the toe of the fabric. If the fence comes out of the ground, do not “accept” the installation.**
- If there are long, linear runs of silt fence, J-hooks or “smiles” should be installed.
- Sediment shall be cleaned from behind the fence when it reaches 50% of the designed impoundment height 9 inch (0.2 m).
- Silt fences and filter barriers shall be inspected weekly after each significant storm (1 inch in 24 hours). Any required repairs shall be made immediately.
- Silt fences shall be removed when they have served their useful purpose, but not before the upslope area has been permanently stabilized and any sediment stored behind the fence has been removed.



Silt fence should never to be used where concentrated flows occur.

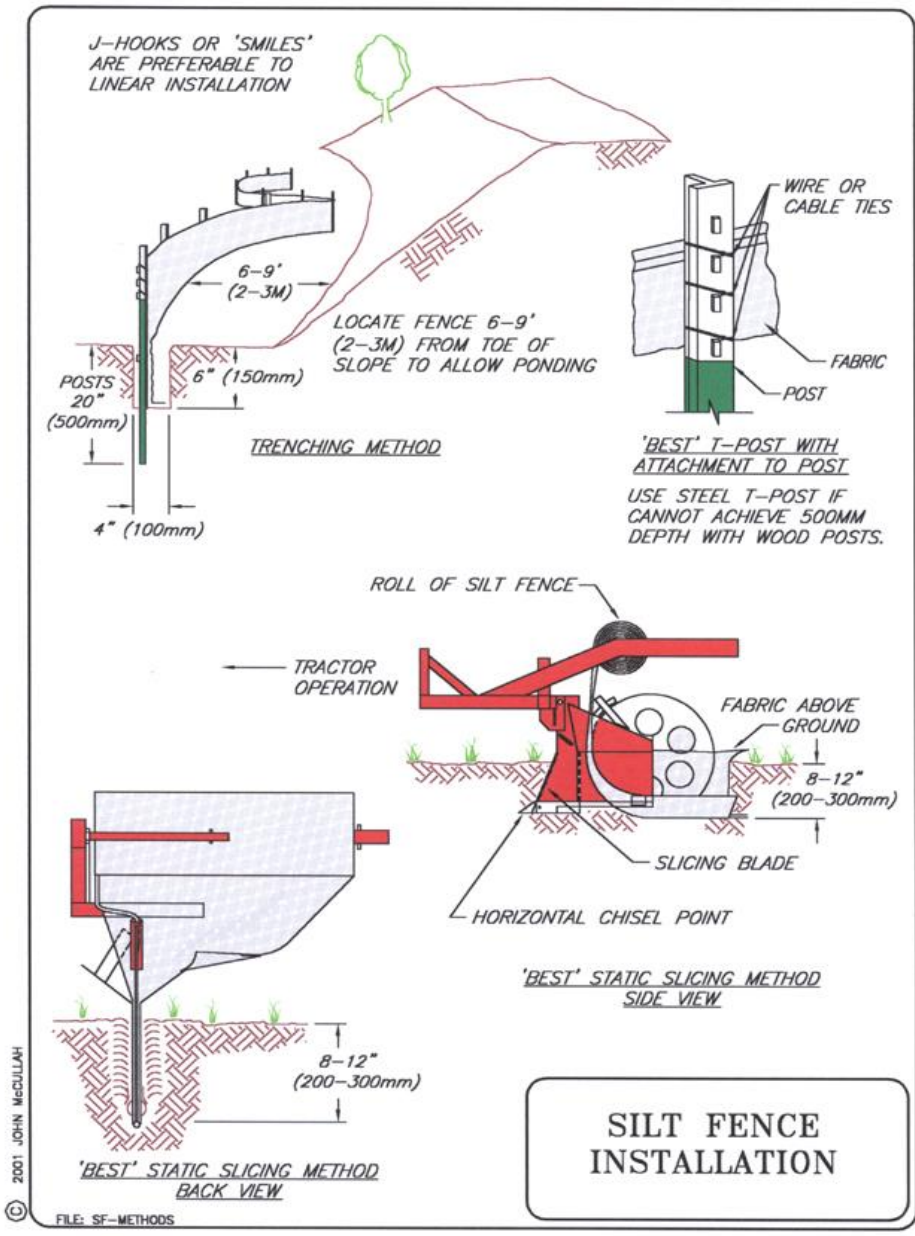

**SILT FENCE
INSTALLATION**

Typical Drawing: Silt Fence Installation

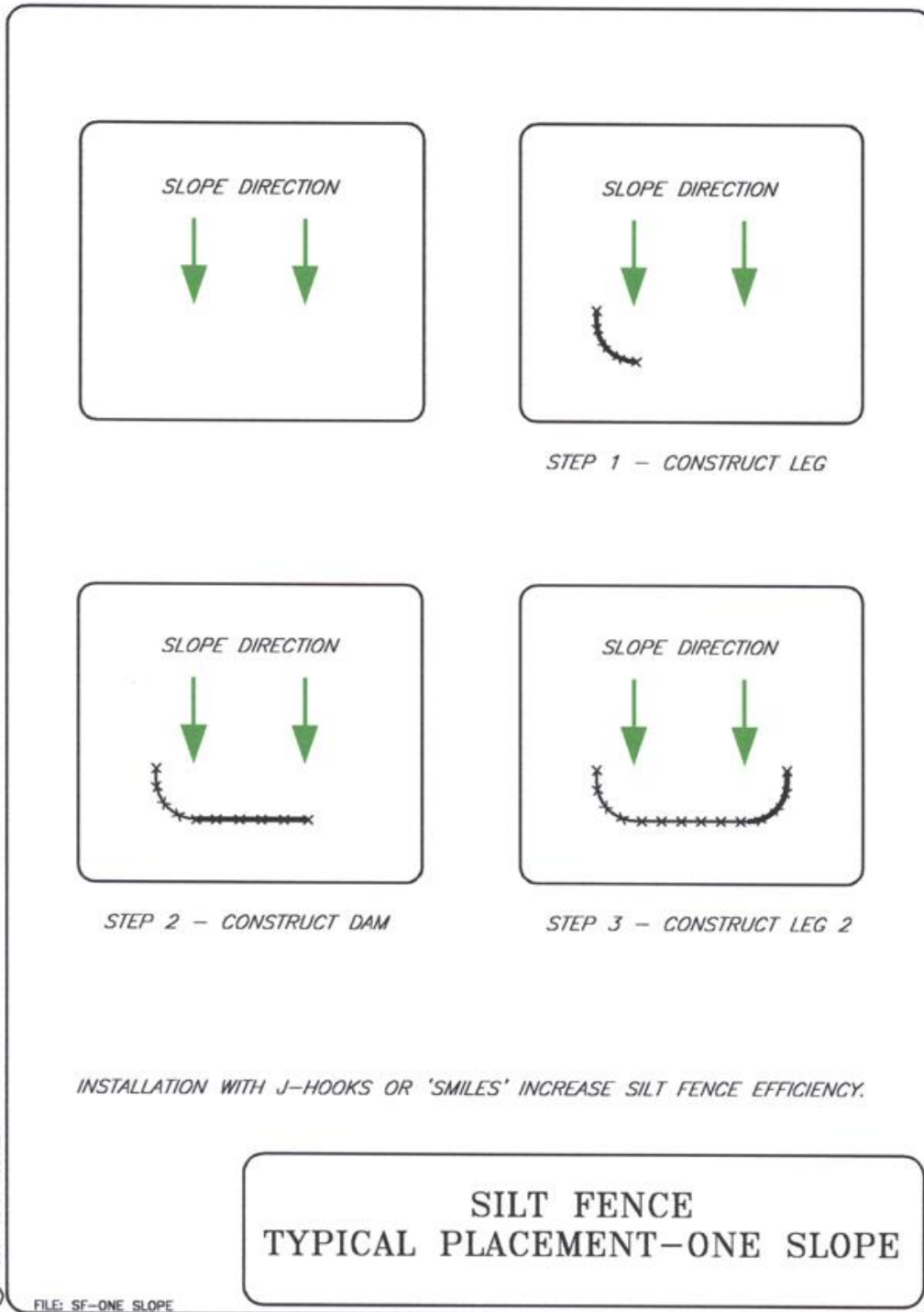

Typical Drawing: Silt Fence Typical Placement - One Slope

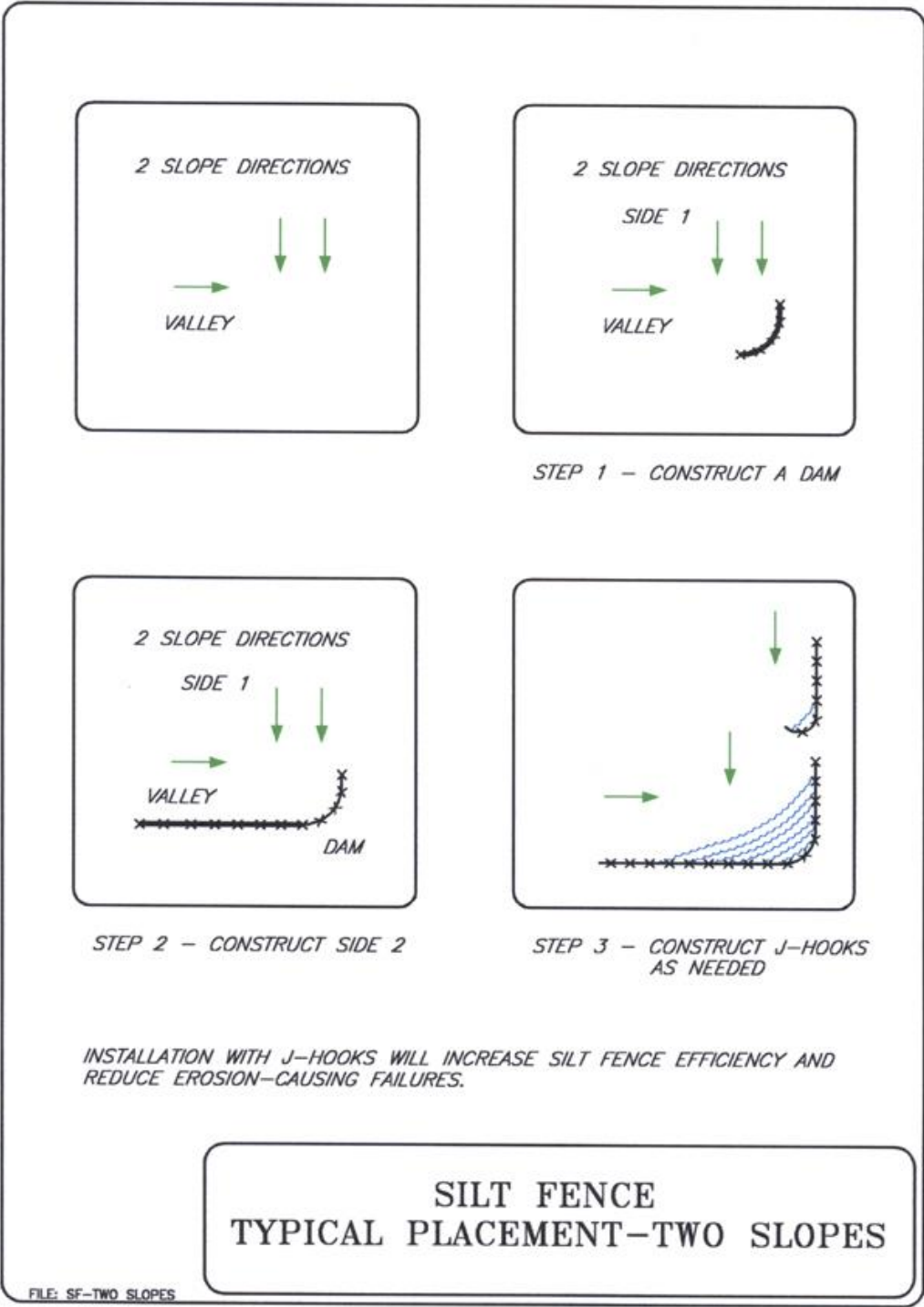

Typical Drawing: Silt Fence Typical Placement - Two Slopes

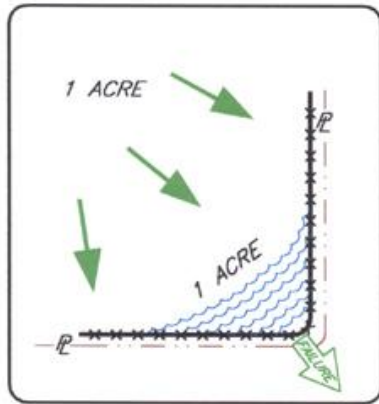

Incorrect – Do Not layout “perimeter control” silt fences along property lines. All sediment laden runoff will concentrate and overwhelm the system.

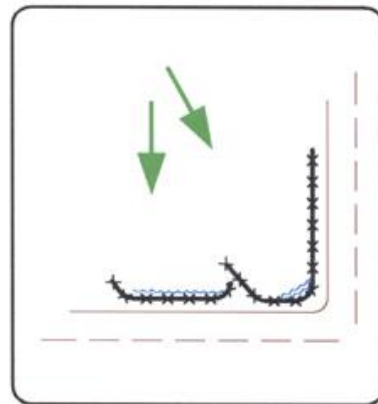

Correct – Install J-hooks

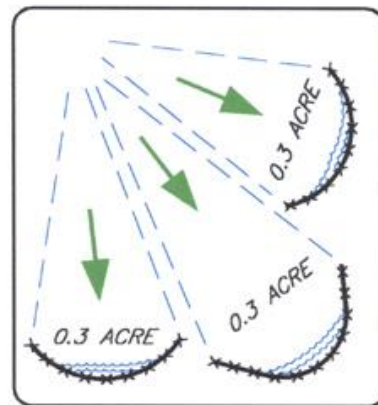
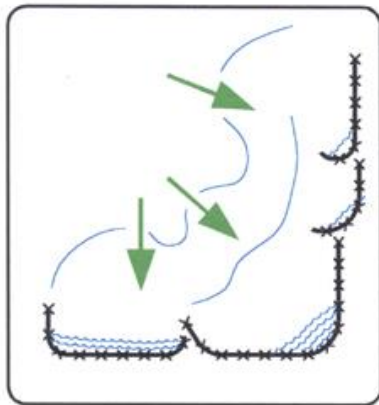

Discreet segments of silt fence, installed with J-hooks or ‘smiles’ will be much more effective.

SILT FENCE PLACEMENT FOR PERIMETER CONTROL

© 2001 JOHN McCULLAH

FILE: SF-PERIMETER CONTROL

Typical Drawing: Silt Fence Placement for Perimeter Control

DROP INLET SEDIMENT BARRIERS

Definition:

A drop inlet sediment barrier is a temporary barrier placed around a drop inlet. The sediment barrier may be constructed of straw bales and gravel, gravel and stone, block and gravel, or silt fence material.

Note: Straw bale and silt fence drop inlet sediment barriers both have very high failure rates. Monitoring of these BMPs reveals that these practices rarely prevent sediment discharge into the storm drains.

Purpose:

Drop Inlet sediment barriers are intended to prevent sediment from entering the storm drains during construction operations. This practice allows early use of the storm drain system and is applicable for the phased construction schedule of a wet weather plan. Sediment-laden runoff is ponded before entering the storm drain, thus allowing some sediment to fall out of suspension.

Silt Fence Sediment Barrier:

- Support posts for a silt fence must be steel fence posts or 2 by 4 inch (51 by 102 mm) wood, length 3 foot (0.9 m) minimum, spacing 3 foot (0.9 m) maximum, **with a top frame support required.**
- Excavate a trench 4 inches (101 mm) wide and 6 inches (152 mm) deep and bury the bottom of the silt fence in the trench.
- Backfill the trench with gravel or soil.
- Compact the backfill well.
- The height of the silt fence shall be a 1.5 foot (0.5 m) maximum, measured from the top of the inlet.



Improperly installed and unmaintained silt fence drop inlet barrier.

Gravel Doughnut:

- Keep the stone slope toward the inlet at 3:1 or flatter or use concrete blocks to help prevent the stone from being washed into the drop inlet. A minimum 1 foot (0.3 m) wide level area set 4 inches (101 mm) below the drop inlet crest will add further protection against the entrance of material.
- Stone on the slope toward the inlet should be 3 inches (76.2 mm) or larger for stability, and 1 inch (25.4 cm) or smaller on the slope away from the inlet to control flow rate.

- Wire mesh with 2 inch (51 mm) openings may be placed over the drain grating, but must be inspected frequently to avoid blockage by trash. If concrete blocks are used the openings should be covered with wire screen or filter fabric.

Silt Saver

The Silt Saver is an inlet filter constructed of a reusable rigid plastic frame that fits over the inlet during construction. The frame is covered by filter material that is curved upwards at the bottom so that soil may

Be used to hold the material in close contact with the ground. Independent testing of the silt saver has shown the product to be extremely successful at preventing sediment entry into the inlet. This product

works best when a depressed trap is excavated around the inlet to induce ponding. This allows finer sediments time to fall out of suspension.



Drainguard and Grateguard

These inlet filters have an excellent application for grate inlets in subdivisions after paving and during home construction. The Drainguard is available in a reusable model. The Drainguard has bypass holes for heavy flow situations. Both products are available in a sediment only and an oil and sediment model. Benefits include low to moderate cost and ease of installation and removal.



Photos courtesy of UltraTech

Inspection and Maintenance:

- Inspect the barrier after each rain and promptly make repairs as needed.
- Sediment shall be removed after each significant storm (1 inch (25.4 mm) in 24 hours) to provide adequate storage volume for the next rain.
- The removed sediment shall be deposited in an area that will not contribute sediment off-site and can be permanently stabilized.
- For gravel filters: If the gravel becomes clogged with sediment it must be carefully removed from the inlet and either cleaned or replaced.

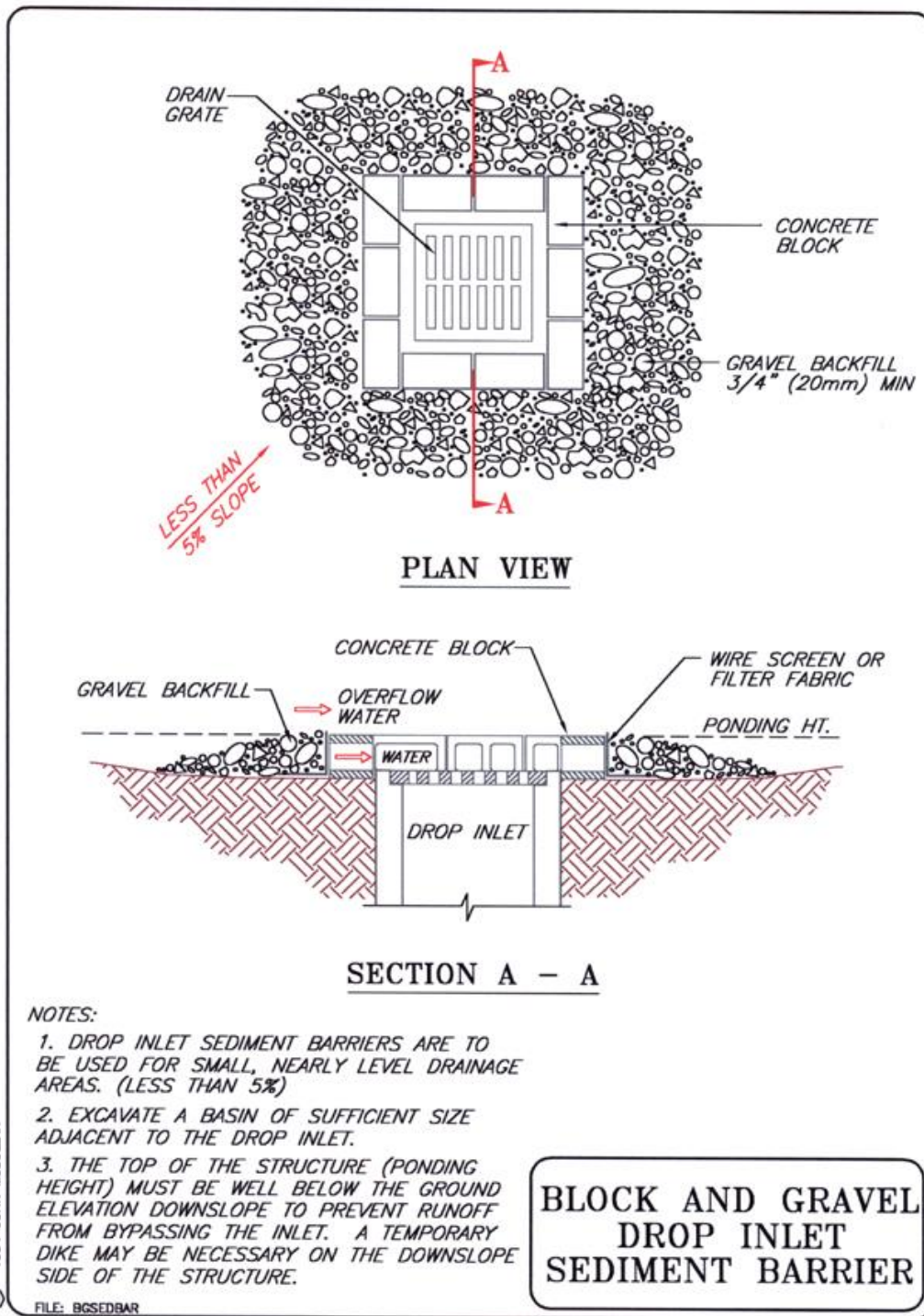

Typical Drawing: Block and Gravel Drop Inlet Sediment Barrier

CURB INLET SEDIMENT BARRIERS

Definition:

Curb inlet sediment barriers are temporary barriers constructed from concrete block and gravel or gravel filled sandbags.

Purpose:

Curb inlet sediment barriers are intended to reduce the sediment discharged into storm drains by ponding the runoff and allowing the sediment to settle out. The structures allow for overflow from high runoff events and the gravel allows the ponds to dewater rapidly.

Design Considerations:

The sandbag curb inlet and block and gravel sediment barrier can be used at curb inlets on gently sloping, paved streets where:

- water can pond and allow sediment to separate out of suspension;
- runoff is relatively low, less than 0.5 ft³/sec (.01 m³/sec).
- Once the small catchment areas behind the sandbags or block and gravel fill with sediment, future sediment-laden runoff will enter the storm drain without being desilted. Therefore, sediment must be removed from these structures during or after each storm. Additional storage can be obtained by constructing a series of sandbag barriers along the gutter so that each barrier traps small amounts of sediment.

Construction Specifications:

- Place the barriers on gently sloping streets where water can pond.
- The barriers must allow for overflow from a severe storm event. Slope runoff shall be allowed to flow over blocks and gravel and not be bypassed over the curb. The sandbag should be of woven-type geotextile fabric since burlap bags deteriorate rapidly. The sandbags shall be filled with 3/4 inch (19 mm) drain rock or 1/4 inch (6 mm) pea gravel.
- The sandbags shall be placed in a curved row from the top of curb at least 3 feet (0.9 m) into the street. The row should be curved at the ends, pointing uphill.
- Several layers of bags should be overlapped and packed tightly.
- Leave a one-sandbag gap in the top row to act as a spillway.

For Block and Gravel Type Barriers:

Place two concrete blocks on their sides perpendicular to the curb at either end of the inlet opening. These are the spacer blocks.

Place concrete blocks on their sides across the front of the inlet and abutting the spacer blocks. The openings in the blocks should face outward, not upward.

Cut a 2 by 4 inch (51 by 102 mm) stud the length of the curb inlet plus the width of the two spacer blocks. Place the stud through the outer hole of each spacer block to help keep the front blocks in place. Place wire mesh over the outside vertical face (open ends) of the blocks to prevent stone from being washed through the blocks.

Use chicken wire, hardware cloth with 1/2 inch (13 mm) openings, or filter fabric.

Place 3/4 - 1 1/3 inch (19-34 mm) gravel against the wire to the top of the barrier.

Inspection and Maintenance:



Block and gravel curb inlet sediment barrier.

- Inspect and clean barrier during and after each significant storm and remove sediment from behind sandbag structure after every storm.
- Any sediment and gravel shall be immediately removed from the traveled way of roads.
- The removed sediment shall be placed where it cannot enter a storm drain, stream, or be transported off site.



Geotextile curb inlet sediment barriers work well under low flow, low sediment conditions (see DrainGaurd above).

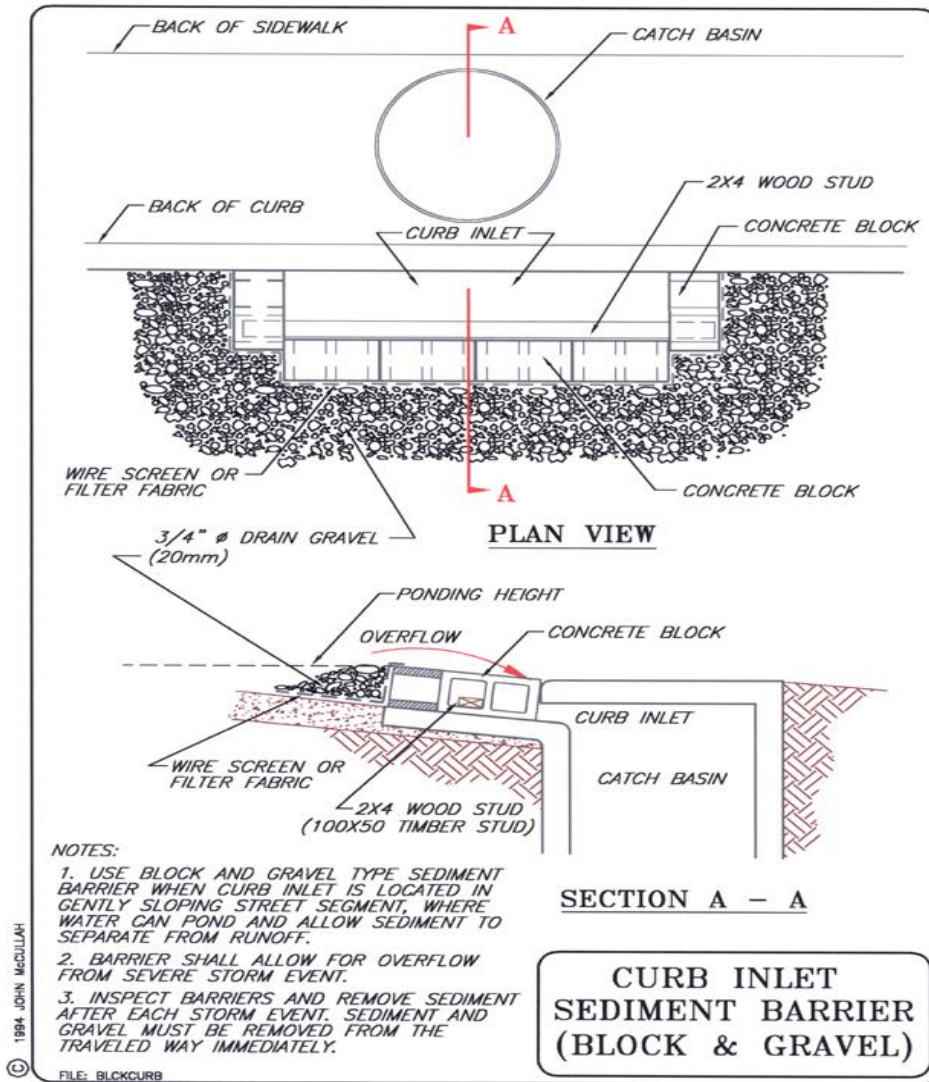

Typical Drawing: Curb Inlet Sediment Barrier (Block and Gravel)

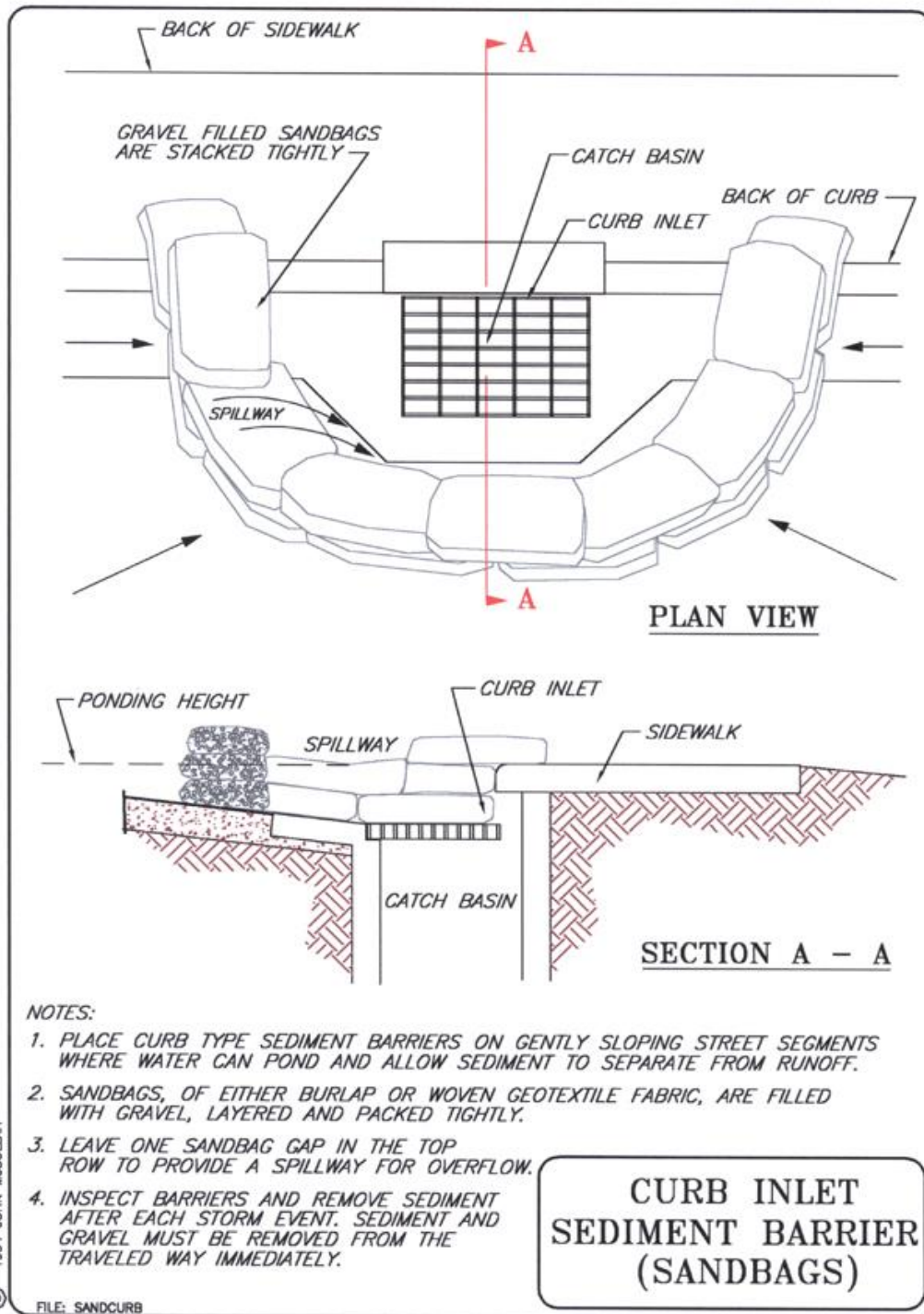

Typical Drawing: Curb Inlet Sediment Barrier (Sandbags)

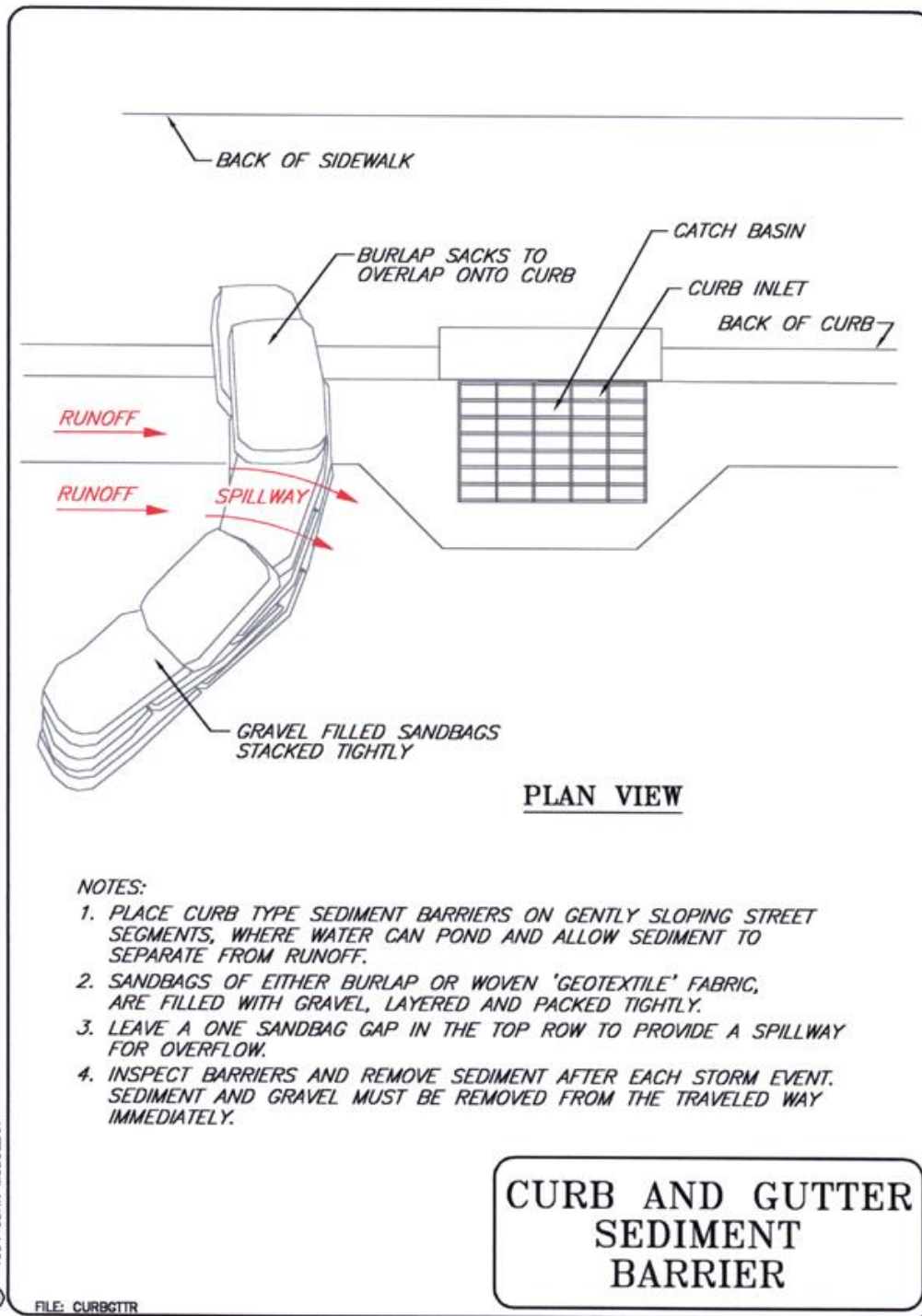

Typical Drawing: Curb and Gutter Inlet Sediment Barrier

CHAPTER 7 BANK STABILIZATION / BIOENGINEERING

STRUCTURAL STREAMBANK STABILIZATION

Definition:

Streambank stabilization may take many forms including gabions and riprap. Gabions are rectangular wire baskets filled with stones used as pervious, semi-flexible building blocks. Live rooting branches may be placed between the rock-filled baskets.

Purpose:

To protect streambanks from the erosive forces of moving water. Rock-filled gabions can be used to armor the bed and/or banks of channels or used to divert flow away from eroding channel sections.

Conditions Where Practice Applies:

Rock-filled or vegetated rock gabions are applicable to streambank sections, which are subject to excessive erosion due to increased flows or disturbance during construction. This practice is applicable where flow velocities exceed 6 ft./sec. (2 m/sec.) and where vegetative streambank protection alone is not sufficient. Gabions can be used to construct deflectors or groins intended to divert flow away from eroding streambank sections. Gabions are also used to construct retaining walls and grade control structures.

Gabions and gabion mattresses (which essentially are rock blankets consisting of a layer of rock encased by wire) are often preferable to rock riprap alone. For any given hydraulic condition, the gabion or gabion mattress revetment thickness is one third (1/3) of an equivalent riprap design. Gabions and gabion mattresses are flexible and free draining thus allowing some soil settling. They can be used in unstable streambeds and streambanks. Gabions can provide an important component to a 'bioengineering' solution for streambank or slope erosion because they allow the growth and establishment of natural vegetation.

Site Considerations:

All of the general streambank stabilization considerations are to be followed. The following are specific considerations for gabion structures.

Gabion walls are appropriate where:

- The vertical integrity of a soil bank needs a higher tensile strength to reduce sloughing of the streambank.
- There is moderate to excessive sub-surface water movements that may be creating erosion and damage other types of non-permeable structures.
- An excessively steep stream bank must be stabilized and vegetative or extreme mechanical means of stabilization (i.e., pulling back bank) are not a feasible due to site conditions.
- Where slope must be modified while heavy machinery is unavailable to the site.
- Fill must be disposed of along an eroding streambank (fill can be placed behind gabion to modify slope).
- A retaining or toe wall is needed to stabilize the slope.

Types of Gabion Structures:

- Gabion Wall: Basically a gravity wall which relies on its own weight and frictional resistance to resist sliding and overturning from lateral earth pressure.

- **Vegetated Rock Gabion:** A rock-filled gabion earth-retaining structure which has live branches placed between each consecutive layer of rock-filled baskets. The live branches will take root inside the gabion and into the soil behind the structure. The vegetation will consolidate the structures and bind it to the slope.
- **Gabion Deflector:** Deflector or groins project into the streams and divert flows away from eroding streambank sections.
- **Gabion Aprons:** Rock filled gabions or gabions mattress used as outlet protection, energy dissipaters or spillways. These semi-flexible gabions are designed to settle without fracture and adhere to the ground if scour occurs.
- **Grade Control:** Drop structures or weirs. Gabion baskets and mattresses can be combined to construct check dams or weirs.
- **Channel Lining:** Gabion mattresses can be used to line channels. The lining thickness depends on many factors such as the type of rock, design flow velocity, sediment and bed load, and channel gradient.

Vegetated Riprap:

Vegetated riprap should be used where channel velocity does not require the use of gabions. This practice is excellent when stabilization is needed, but a more natural and aesthetically pleasing embankment is called for. The vegetation will provide stream shading for temperature control as well as wildlife habitat and a contribution of organic matter to the stream ecosystem.

Construction Specifications:

- Gabions shall be fabricated in such a manner that the sides, ends, lid and diaphragms can be assembled at the construction site into rectangular baskets of the sizes specified and shown on the construction drawings.
- Gabions shall be of single-unit construction; the base, lid, ends and sides shall be either woven into a single unit or one edge of these members connected to the base section of the gabion in such a manner that the strength and flexibility at the connecting point is at least equal to that of the mesh.
- Where the length of the gabion exceeds 1.5 times its horizontal width, the gabion shall be divided by diaphragms of the same mesh and gauge as the body of the gabion, into cells whose length does not exceed the horizontal width.
- The stone size to fill gabion shall be 3-5 inches (76-127 mm) for gabion mattresses and 4-8 inches (101-203 mm) for gabion.

Inspection and Maintenance:

Structural damage caused by storm events should be repaired as soon as possible to prevent further damage to the structure or erosion of the streambank.

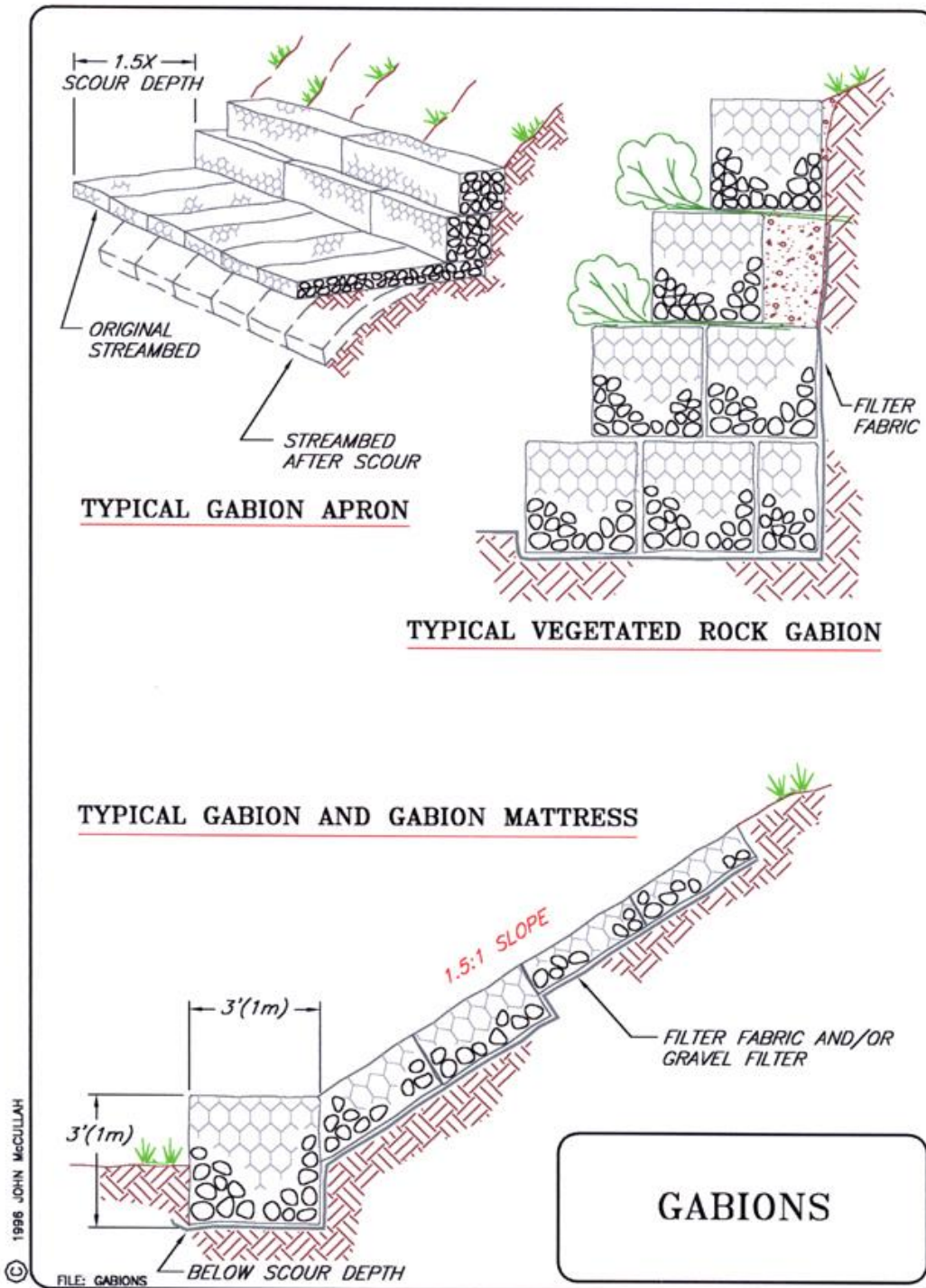

Typical Drawing: Gabions

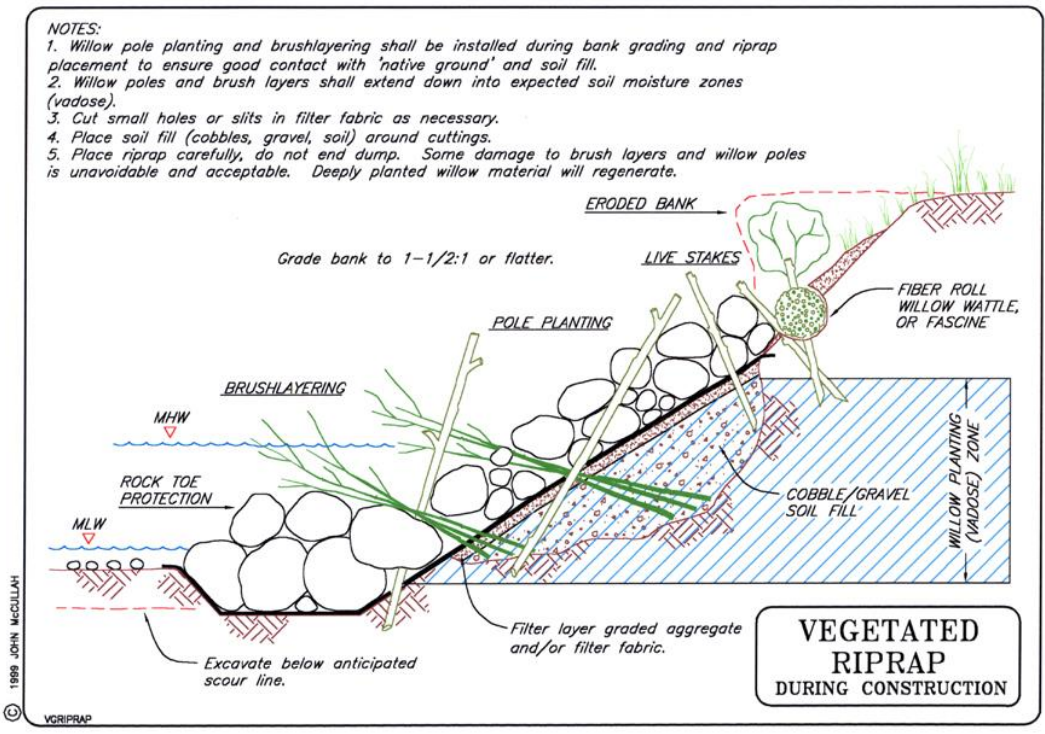

Typical drawing: Vegetated Riprap

Appendix A: REFERENCES

- AGH Marketing, Inc. Manufacturer's Product Information and Specifications. Houston, TX.
- Association of Bay Area Governments (ABAG). 1995. *Manual of Standards for Erosion & Sediment Control Measures*, Second Edition. Oakland, California.
- Atkins, Pearce, PE. 2004. *Personal Communication*.
- BonTerra America. Manufacturer's Product Information and Specifications. Moscow, Idaho.
- Bestmann Green Systems. Manufacturer's Product Information and Specifications. Salem, MA.
- Cable, James K., P.E., Harold Dolling. 1994. *Iowa Construction Site Erosion Control Manual*. Iowa Department of Natural Resources.
- California Association of Resource Conservation Districts. 1986. *California Interagency Seeding Guide for Erosion Control Plantings*.
- Delaware, State of, Department of Natural Resources and Environmental Control, Division of Soil and Water Conservation. 1989. *Delaware Erosion and Sediment Control Handbook*. Delaware Department of Natural Resources. Dover, Delaware.
- Environmental Protection Agency (EPA). 1992. *Storm Water Management for Construction Activities. Developing Pollution Prevention Plans and Best Management Practices*. National Technical Information Service. Springfield, VA.
- Georgia Soil and Water Conservation Commission. 2002. *Field Manual for Erosion and Sediment Control in Georgia 4th Edition*. Athens, GA.
- Gray, D.H., A.T. Leiser. 1982. *Biotechnical Slope Protection and Erosion Control*. Van Nostrand Reinhold. New York, NY. Krieger Pub. Co., Melbourne, FL.
- Goldman, S., K. Jackson, and T. Bursztynsky, P.E. 1986. *Erosion & Sediment Control Handbook*. McGraw - Hill, Inc.
- Maccaferri Gabions, Inc. Manufacturer's Product Information and Specifications. Williamsport, MD.
- McCullah, John. 2002. *Erosion Draw 4.0 CD*. Salix Applied Earthcare. Redding, CA.
- McCullah, J.A. 2001 Erosion Control BMPs for Construction Activities and Biotechnical Techniques for Watershed Restoration. Shasta College Printing Office, Redding, CA 96001.
- McCullah, John. CPESC. 1994. *Erosion Draw: Erosion and Sediment Control Manual for Computer Aided Drafting*. Salix Applied EarthCare. Redding, CA.
- Modular Gabion Systems, Inc. Manufacturer's Product Information and Specifications. Houston, TX.
- North American Green. Manufacturer's Product Information and Specifications. Evansville, IN.

North Carolina Department of Environment, Health, and Natural Resources. 1991. *Erosion and Sediment Control Field Manual*. North Carolina Sedimentation Control Commission. Raleigh, NC.

North Carolina Sedimentation Control Commission. 1988. *Erosion and Sediment Control Planning and Design Manual*. Raleigh, NC.

Presto Products Company. Manufacturer's Product Information and Specifications. Appleton, WI.

RoLanka International, Inc. Manufacturer's Product Information and Specifications. Morrow, GA.

South Carolina Forestry Commission. 1994. *South Carolina's Best Management Practices for Forestry*. Columbia, SC.

South Carolina Soil and Water Conservation Society. 2002. *Handbook for Stormwater Management and Sediment Reduction*. Savannah River Site in Aiken, SC.

Synthetic Industries Engineered Geosynthetics. Mark Theisen. Manufacturer's Product Information and Specifications. Chattanooga, TN.

United States Department of Agriculture, Soil Conservation Service. 1982. *Road Building Guide for Small Private Roads*. Mendocino County, CA.

United States Department of Agriculture, Soil Conservation Service. 1983. *Guide to Building Small Private Roads*. Davis, CA

United States Department of Agriculture, Natural Resources Conservation Service. 1992. *Engineering Field Handbook*. Chapter 18, Soil Bioengineering for Upland Slope Protection and Erosion Reduction. Washington, DC.

United States Department of Agriculture, Natural Resources Conservation Service. 1993. *How to Plant Willow and Cottonwoods for Riparian Rehabilitation*. Technical Notes, Plant Material #23. PMC, Aberdeen, ID.

Weiner, Eugene R. 2000. *Applications of Environmental Chemistry*. Lewis Publishers. Boca Raton, FL.

Virginia Department of Conservation and Recreation, Division of Soil and Water Conservation. 1992. *Virginia Erosion and Sediment Control Handbook*, Third Edition. Richmond, Virginia.

ORDINANCE NO. 2021-22
AMENDING CHAPTER 14, ARTICLE V, DIVISION 3
OF THE CITY CODE OF THE
CITY OF NORTH AUGUSTA, SOUTH CAROLINA

BE IT ORDAINED BY THE MAYOR AND CITY COUNCIL OF THE CITY OF NORTH AUGUSTA, SOUTH CAROLINA, IN MEETING DULY ASSEMBLED AND BY THE AUTHORITY THEREOF, THAT:

- I. Chapter 6, Article V, Division 3 entitled “Construction Permitting for Land Disturbing Activities,” is hereby amended, and when amended shall read as follows:

DIVISION 3. CONSTRUCTION PERMITTING FOR LAND DISTURBING ACTIVITIES

Section 14-170. Purpose/intent

(No Change)

Section 14-170.1 Definitions

Bioretention: A stormwater treatment practice that uses a combination of plants and pervious soils to treat water quality and, to a limited extent, may address water quantity.

Clearing: Any activity that removes the vegetative surface cover.

Constructed wetland: A shallow water quality pond that mimics natural wetland functions using wetland plants.

Drainage way: Any channel that conveys surface runoff throughout the site.

Erosion control: Measures that minimize or prevent erosion such as mulches, erosion control matting, and grassing.

Erosion and sediment control plan: A set of plans prepared by or under the direction of a licensed professional engineer that indicates the specific measures and sequencing to be used in controlling sediment and erosion on a development site both before, during and after construction.

Forebay: A small pond at the head of a detention pond for the purpose of collecting sediment and facilitating simplified sediment removal.

Grading: Excavation or fill of material, including the resulting conditions thereof.

Perimeter control: A barrier that prevents sediment from leaving a site either by filtering sediment-laden runoff, or diverting it to a sediment trap or basin.

Phasing: Clearing a parcel of land in distinct phases, with the stabilization of each phase before the clearing of the next.

Sediment control: Measures that prevent eroded sediment from leaving the site.

Site: A parcel of land, or a contiguous combination thereof, where grading work is performed as a single unified operation.

Stabilization: The use of practices that prevent exposed soil from eroding (usually grass, mulch, geotextile fabric, or rock).

Start of construction: The first land-disturbing activity associated with a development, including land preparation such as clearing, grading and filling; installation of streets and walkways; excavation for basements, footings, piers or foundations; erection of temporary forms; and installation of accessory buildings such as garages.

Stormwater management manual: The manual produced by the city stormwater management department that provides requirements, guidance, and technical specifications for complying with this division.

Stormwater Maintenance Agreement: A written agreement from the landowner or responsible party assuring the maintenance and inspection of storm water management facilities and/or Best Management Practices related to them are maintained in proper working condition as shown or described on the approved development site plan in order to serve the intended purposes as set forth in this Ordinance and state regulations. The agreement grants permission of City or State inspectors to verify compliance. The agreement must be recorded with the land record for the parcel in the county it is located.

Stormwater treatment practice (STP): Any structural method of treating stormwater quantity or quality.

Section 14-170.2. Stormwater management permit required; exceptions.

(a) The surface of land in the city shall not be disturbed or altered for any purpose whatsoever until a stormwater management permit is issued to the person responsible for such construction. No permit shall be issued until the applicant has submitted a plan to control erosion and sedimentation and such plan has been approved by the city engineer or his designated representative. Additional permits required, must be acquired prior to start of construction.

(b) Exemptions.

- (1) Any emergency activity that is immediately necessary for the protection of life, property or natural resources.
- (2) Existing nursery and agricultural operations conducted as a permitted main or accessory use.
- (3) Land disturbing activities undertaken on forest land for the production and harvesting of timber and timber products.
- (4) Land disturbing activities conducted pursuant to a federal environmental permit, including permits issued under section 404 of the Federal Clean Water Act.
- (5) Projects regulated under the SC Mining Act.
- (6) Construction, renovation or land improvement of single-family residences, one duplex dwelling or their accessory buildings which are separately built and not part of a

subdivision development, and not located within the designated 100-year floodplain, provided that such construction does not materially impede the runoff capability of the existing major drainage channels.

- (7) Certain activities undertaken by utility providers that are not substantial land disturbing activities and are therefore not intended to be regulated by this chapter. These activities include but are not limited to the following:
 - a. Installation of utilities on sites of one acre or less.
 - b. Projects undertaken under jurisdiction of the state public service commission, and including work permitted by the Federal Energy Regulatory Commission.
 - c. Installation of utilities in a ditch section one foot or less in width.
 - d. Installation of utility poles.
 - e. Maintenance of easements and rights-of-way.
 - f. Service connections (i.e. tapping mains lines and/or setting meters, including installation of a manhole, valve box or fire hydrants).
 - g. Emergency repairs.
- (8) Construction activities of the state department of transportation.
- (9) Activities relating to the routine maintenance and/or repair or rebuilding of the tracks, rights-of-way, bridges, and any other related structures and facilities of a railroad company.
- (10) Minor land disturbing activities, as determined by the city engineer, which would not violate the integrity of this chapter.

Section 14-170.3. Application, review and approval, and issuance of stormwater management permit.

(a) *Application.* All applications for stormwater management permits shall be submitted to the Stormwater Management Department (SWMD) through the Planning and Development Department for processing and permit issuance. Applications for permits shall be accompanied by three (3) copies of the applicants stormwater and erosion control plan. Stormwater and erosion control plans shall conform to the requirements of section 14-174.

- (1) Each application shall bear the name(s) and address(es) of the owner or developer of the site, and of any consulting firm retained by the applicant together with the name of the applicant's principal contact at such firm.
- (2) Each application shall include a statement that any land clearing, construction, or development involving the movement of earth shall be in accordance with the erosion and sediment control plan, and that an authorized representative shall inspect the site every seven (7) days and after every one-half-inch rain to ensure compliance with the plan.

- (b) *Fee.* The application shall be accompanied by nonrefundable fee.

(c) *Review and approval.* The SWMD will review each application for a stormwater management permit to determine its conformance with the provisions of this regulation. Within ten (10) working days after receiving an application, the SWMD shall, in writing:

- (1) Approve the permit application;
- (2) Approve the permit application subject to such reasonable conditions as may be necessary to secure substantially the objectives of this regulation, and issue the permit subject to these conditions; or
- (3) Disapprove the permit application, indicating the deficiencies and the procedure for submitting a revised application and/or submission.

Failure of the SWMD to act on original or revised applications within ten (10) working days of receipt shall authorize the applicant to proceed in accordance with the plans as filed unless such time is extended by agreement between the applicant and the SWMD.

Major amendments of the stormwater and erosion control plan shall be submitted to the SWMD and shall be processed and approved, or disapproved, in the same manner as the original plans for a fee assessed at fifty percent (50%) of the original stormwater review fee for the permit. Field modifications of a minor nature may be authorized by the SWMD by written authorization to the permittee.

Transfer of ownership of permitted projects is allowed with proper notification to the stormwater department during the permit period.

Section 14-170.4. Stormwater and erosion control plans

(a) *General requirements.*

- (1) Stormwater and erosion control plans for land disturbance activities of one (1) acre or more must be prepared by a registered professional engineer, registered landscape architect, or tier B land surveyor licensed by the state.
- (2) Applications shall include a natural resources map identifying soils, forest cover, and resources protected by other agencies having jurisdiction.
- (3) A sequence of construction of the development site, including stripping and clearing, rough grading, construction of utilities, infrastructure, and buildings, and final grading and landscaping. Sequencing shall identify the expected date on which clearing will begin, the estimated duration of exposure of cleared areas, and the sequence of clearing, installation of temporary erosion and sediment measures, and establishment of permanent vegetation.
- (4) Provisions for maintenance of stormwater control facilities, including easements and estimates of the cost of maintenance. An executed, signed, and notarized maintenance agreement and maintenance plan from the responsible party(ies) or individual(s) accepting ownership and maintenance of permanent stormwater control devices/structures during construction must be provided prior to stormwater permit issuance.
 - a. A notarized permanent stormwater maintenance responsibility agreement and a maintenance plan for stormwater control facilities or treatment practices must be executed and must be recorded as part of the land/property record in the county

where it is located and the agreement constitutes a covenant running with the land, and shall be binding on the Landowner, its administrators, executors, assigns, heirs and any other successors in interests, including but not limited to any homeowners' association. This step must be completed prior to requesting a notice of termination (NOT) for your stormwater permit.

- b. Any changes in permanent maintenance responsibilities must be documented with a new notarized maintenance agreement and maintenance plan and recorded with the land in the county in which it resides as soon as approved by the city. The city must be notified of the change by providing a new notarized agreement and a letter of acceptance from the entity accepting permanent maintenance responsibilities. Prior to executing a change of ownership of maintenance responsibility, a letter of inspection may be requested by either party involved and obtained from the city SWMD at no fee. Subsequent inspection letters if requested will be available for a \$50.00 fee to be paid prior to the inspection.
- c. Failure to execute, record and/or acquire approval from the city for a change of ownership and maintenance responsibilities agreement for the stormwater control devices at a site constitutes leaving the original recorded agreement in force, and that agreement will be enforceable by the stormwater department for maintenance responsibility.

(b) *Water quantity design requirements.*

- (1) Stormwater management requirements for a specific project shall be based on the entire area to be developed, or if phased, the initial submittal shall control that area proposed in the initial phase and establish a procedure and obligation for total site control.
- (2) Post-development peak discharge rates shall not exceed pre-development discharge rates for the two-, ten-, and twenty-five-year frequency twenty-four-hour duration storm event.
- (3) Discharge velocities shall be reduced to provide a nonerosive velocity flow from a structure, channel, or other control measure or the velocity of the twenty-five-year, twenty-four-hour storm runoff in the receiving waterway prior to the land disturbing activity, whichever is greater.
- (4) Watersheds, other than designated watersheds, that have well documented water quantity problems may have more stringent, or modified, design criteria as determined by the SWMD for development or redevelopment.
- (5) An emergency spillway should safely pass the 100-year storm event.
- (6) Dry ponds must dewater within seventy-two (72) hours.
- (7) Additional requirements are found in the stormwater management manual.

(c) *Water quality design requirements.*

- (1) *Clearing and grading.*

- a. Clearing and grading of natural resources, such as forests and wetlands, shall not begin until all applicable local, state, and federal permits have been granted.
 - b. Clearing techniques that retain natural vegetation and retain natural drainage patterns, as described in the stormwater management manual, should be used.
 - c. Phasing shall be required on all sites disturbing greater than twenty (20) acres, with the size of each phase to be established at plan review and as approved by the SWMD.
 - d. Clearing, except that necessary to establish sediment control devices, shall not begin until all sediment control devices have been installed and have been stabilized.
- (2) *Erosion control.* Plans shall include all erosion and sediment control measures necessary to meet the objectives of this regulation throughout all phases of construction and permanently, after completion of development of the site.
- a. Soil must be stabilized within fourteen (14) days of clearing or inactivity in construction.
 - b. If vegetative erosion control methods, such as seeding, have not become established within twenty-one (21) days, the SWMD may require that the site be reseeded, or that a non-vegetative option be employed.
 - c. On steep slopes or in drainage ways, special techniques that meet the design criteria outlined in the stormwater management manual shall be used to ensure stabilization.
 - d. Soil stockpiles must be stabilized or covered within twenty-one (21) days of inactivity.
 - e. Techniques shall be employed to prevent the blowing of dust or sediment from the site.
 - f. Techniques that divert upland runoff past disturbed slopes shall be employed.
 - g. Energy dissipation shall be provided at all outfalls.
- (3) *Sediment control.*
- a. Sediment controls shall be provided in the form of settling basins or sediment traps or tanks, and perimeter controls.
 - b. Where possible, settling basins shall be designed in a manner that allows adaptation to provide long-term stormwater management.
 - c. Adjacent properties shall be protected with perimeter controls.
 - d. A fifty-foot long by six-inch deep stone construction exit shall be provided.
- (4) *Stormwater treatment practices.* Post-construction water quality must be addressed for all sites containing one or more acres of disturbance.
- a. Water quality volume design requirements require implementation of the one-inch sizing criterion.

One-inch sizing: The first one inch of water from any storm event, draining from that portion of the site that discharges to the stormwater treatment unit, must be collected and released over a twenty-four-hour period.

- b. Dry ponds are not an acceptable stand-alone water quality treatment technology. When used they should be preceded by a forebay and used in conjunction with infiltration, vegetative filters, or inline treatment. Dry ponds must dewater within seventy-two (72) hours.
- c. Technologies that may be used to meet water quality requirements include but are not limited to infiltration, bioretention, in-line treatment devices, disconnected impervious areas, vegetated filter strips, constructed wetlands, and wet ponds. Vegetative swales combined with bioretention or another infiltration technology is the preferred method of water quality treatment. Landscaped areas should be designed, where possible, to incorporate stormwater management. Peak flow control may be achieved by adding inline or overflow storage such as parking lot detention, pipe storage or a dry pond.

Sec. 14-170.5. Design guidelines.

Specific requirements, guidance and technical specifications for compliance with this ordinance are found in the city stormwater management manual. Although the intention of the plan is to establish uniform design practices, it neither replaces the need for engineering judgment nor precludes the use of information not presented. Other accepted engineering and construction procedures and practices may be used if approved by the SWMD.

Sec. 14-170.6. Variances.

The Stormwater Management Department may grant a written variance from any requirement of the stormwater management requirements if there are exceptional circumstances applicable to the site such that strict adherence to the provisions of these regulations will result in unnecessary hardship and not fulfill the intent of the policy. A written request for variance shall be provided to the SWMD and shall state the specific variances sought and the reasons with supporting data for their granting. The SWMD shall not grant a variance unless and until the applicant provides sufficient specific reasons justifying the variance. The SWMD will conduct its review of the request for variance within ten (10) working days. Failure of the SWMD to act by the end of the tenth working day will result in the automatic approval of the variance.

A project may be eligible for a waiver or variance of stormwater management for water quantity control if the applicant can demonstrate that:

- (1) The proposed project will return the disturbed area to a pre-development runoff condition and the pre-development land use is unchanged at the conclusion of the project.
- (2) The proposed project does not increase the rate of runoff from a site by more than one cfs for each of the two-, ten- and twenty-five-year storm events and the disturbed area is less than one acre.

- (3) The proposed project will have no significant adverse impact on the receiving natural waterway or downstream properties; or
- (4) The imposition of peak control requirements for rates of stormwater runoff would aggravate downstream flooding.

Sec. 14-170.7. Inspection.

- (a) The SWMD shall conduct routine inspections and shall either approve that portion of the work completed or shall notify the permittee wherein the work fails to comply with the stormwater and sediment control plan as approved. Plans for grading, stripping, excavating, and filling work bearing the stamp of approval of the SWMD shall be maintained at the site during the progress of the work. The permittee shall notify the SWMD at least two (2) working days before the start of construction.
- (b) The permittee or his/her agent shall make regular inspections of all control measures at least every seven (7) days and after every one-half-inch rain event. The purpose of such inspections will be to determine the overall effectiveness of the stormwater and sediment control plan, and the need for additional control measures. All inspections shall be documented in written form.
- (c) The SWMD shall enter the property of the applicant as deemed necessary to make regular inspections to ensure the validity of the reports.
- (d) If inspection of a project results in an "unsatisfactory" rating indicating noncompliance with the site permit, upon request one follow-up re-inspection to verify compliance will be conducted at no charge. All subsequent inspections requested by the permit holder or project manager to verify the site has been brought back into compliance will require a \$50.00 re-inspection fee to be paid to the city prior to re-inspection. The city utilizes an Enforcement Response Plan (ERP) that fully explains the inspection protocols, ratings, time frames set to bring the site into compliance, and enforcement policy.
- (e) The SWMD shall make regular post-construction maintenance inspections of stormwater treatment and control devices and provide a written report to the owner of record (per the stormwater maintenance agreement, or if none, the property owner) of such device outlining deficiencies and required corrective actions.

Section 14-170.8. Construction site pollution prevention

(No Change)

Section 14-170.9. Enforcement

(No Change)

- II. All Ordinances or parts of Ordinances in conflict herewith are, to the extent of such conflict, hereby repealed.

III. This Ordinance shall become effective on second and final reading.

DONE, RATIFIED AND ADOPTED BY THE MAYOR AND CITY COUNCIL OF THE CITY OF NORTH AUGUSTA, SOUTH CAROLINA, ON THIS 20th DAY OF DECEMBER, 2021.

First Reading December 6, 2021

Second Reading December 20, 2021



Briton S. Williams, Mayor

ATTEST:



Sharon Lamar, City Clerk