

**CITY OF NORTH AUGUSTA  
DEPARTMENT OF PUBLIC SERVICES**



**WASTEWATER INTERCEPTOR PIPELINE & MANHOLE REHABILITATION  
PROJECT NUMBER: A-23-C145/2024-07-4290**



## TABLE OF CONTENTS

ARTICLE 1 - INSTRUCTIONS TO BIDDERS .....	5
ARTICLE 2 - EXAMINATION OF WORK SITE .....	6
ARTICLE 3 - BID SUBMITTAL REQUIREMENTS .....	7
ARTICLE 4 - PRE-BID CONFERENCE .....	7
ARTICLE 5 - INTERPRETATIONS AND ADDENDA .....	7
ARTICLE 6 - BID SECURITY .....	8
ARTICLE 7 - CONTRACT TIMES .....	8
ARTICLE 8 - LIQUIDATED DAMAGES .....	8
ARTICLE 9 - SUBSTITUE OR EQUAL ITEMS .....	8
ARTICLE 10 - SUBCONTRACTORS .....	9
ARTICLE 11 - PREPERATION OF BID .....	9
ARTICLE 12 - SUBMITTAL OF BID .....	10
ARTICLE 13 - MODIFICATION WITHDRAWL OF BID .....	10
ARTICLE 14 – OPENING OF BIDS .....	10
ARTICLE 15 - EVALUATION OF BIDS .....	10
ARTICLE 16 – BONDS AND INSURANCE .....	11
ARTICLE 17 - BIDDER ACKNOWLEDGEMENTS .....	11
ARTICLE 18 - BASIS OF BID .....	12
ARTICLE 19 - MEASURE OF PAYMENT .....	13
ARTICLE 20 - BID FORM .....	15
ARTICLE 21 – SIGNING OF AGREEMENT .....	16
<b>BIDDER FORMS</b>	
ADDENDUM .....	14
CONTRACTOR QUALIFICATIONS .....	17
CONTRACTOR REFERENCES .....	18
LIST OF SUBCONTRACTORS .....	19
AFFIDAVIT OF NONCOLLUSION .....	20

DEBARRMENT AND SUSPENSION CERTIFICATION ..... 21

**TECHICAL SPECIFICATIONS**

CURED-IN-PLACE-PIPE SPECIFICATIONS ..... 22  
MANHOLE REHABILITATION ..... 30  
MANHOLE DETAIL DRAWING - 1 ..... 36  
MANHOLE FRAME AND COVER DETAIL DRAWING - 2 ..... 37  
BY-PASS PUMPING SPECIFICATIONS ..... 38

**STANDARD GENERAL CONDITIONS OF THE  
CONSTRUCTION CONTRACT**

ARTICLE 22 – PRELIMINARY MATTERS ..... 39  
ARTICLE 23 - DOCUMENTS INTENT AND REQUIREMENTS ..... 40  
ARTICLE 24 COMMENCEMENT AND PROGRESS OF WORK ..... 42  
ARTICLE 25 – AVAILABILITY OF LANDS ..... 43  
ARTICLE 26 – BONDS AND INSURANCE ..... 44  
ARTICLE 27 – CONTRACTOR’S RESPONSIBILITY ..... 45  
ARTICLE 28 – OWNER’S RESPONSIBILITY ..... 49  
ARTICLE 29 - OWNERS’ STATUS DURING CONSTRUCTION OWNER’S ..... 50  
ARTICLE 30 – AMENDING THE CONTRACT ..... 51  
ARTICLE 31 – CLAIMS ..... 53  
ARTICLE 32 - COST OF WORK ..... 54  
ARTICLE 33 – INSPECTIONS, TEST AND DEFECTS ..... 54  
ARTICLE 34 – PAYMENTS TO CONTRACTOR ..... 55  
ARTICLE 35 - SUSPENSION AND TERMINATION OF WORK ..... 59  
ARTICLE 36 – FINAL RESOLUTION TO DISPUTES ..... 59  
ARTICLE 37 – MISCELLANEOUS ..... 60

**CONTRACTOR CERTIFICATION FORMS**

DRUG FREE WORKPLACE CERTIFICATION ..... 61  
LOBBYING CERTIFICATION ..... 62  
EEOC AGREEMENT ..... 63

**EXHIBIT A**

**FEDERAL COMPLIANCE PROVISIONS ..... 64**  
**CONTRACT WORK HOURS AND SAFETY STANDARDS ACT ..... 64**  
**ADMINISTRATIVE, CONTRACTUAL AND LEGAL REMEDIES ..... 64**  
**TERMS AND CONDITIONS FOR FEDERAL CONTRACTS ..... 65**  
**CLEAN AIR ACT AND FEDERAL WATER POLLUTION ACT ..... 65**  
**PROCUREMENT OF RECOVERED MATERIALS ..... 66**  
**CIVIL REIGHTS REQUIREMENT ..... 66**  
**EQUAL OPPORTUNITY CLAUSE ..... 67**

**NOTICES**

**NOTICE OF INTENT TO AWARD ..... 69**  
**NOTICE OF AWARD ..... 70**  
**NOTICE TO PROCEED ..... 71**  
**PROJECT LOCATION WORK SITE MAPS ..... 75**

## INVITATION TO BID

The City of North Augusta is requesting Sealed Bids from qualified Contractors to provide Wastewater Cured-In-Place Pipe (CIPP) & Manhole rehabilitation services. Bids will be received by the Department of Public Services located at 61 Claypit Road North Augusta, SC 29841, until 1:30 p.m. on Wednesday, September 4, 2024, at which time the Bids received will be opened and read publicly aloud. No Bids will be accepted after the date/time stated within this request for Bids.

All envelopes are to be Sealed and Clearly Labeled:

Wastewater Interceptor Pipeline & Manhole Rehabilitation  
Project Number: A-23-C145/2024-07-4290

Please submit in person or mail sealed Bids to:

Department of Public Services  
Attention: James Sutton  
Director of Public Services  
61 Claypit Road  
North Augusta, SC. 29841  
Office (803) 441-4240

### Scope of Work

The work to be done consists of furnishing all material, equipment and labor necessary to structurally rehabilitate approximately 25,951 linear feet of 18-inch pipe, 3,642 linear feet of 21-inch pipe, reline 100 brick manholes and replace 80 manhole frames and covers. The project includes pipe cleaning, CCTV pipe inspections, temporary bypass pumping, temporary traffic control and associated work in accordance with the Specifications and Standard General Conditions of the Construction Contract Documents.

### Project Funding

This project is being funded in whole or in part by the South Carolina Infrastructure Investment Program (SCIIP), which is administered by the South Carolina Rural Infrastructure Authority (RIA) and funded by federal State and Local Fiscal Recovery Funds (SLFRF) through the American Rescue Plan Act (ARPA). All federal SLFRF requirements and SCIIP requirements will apply to the contract. All contractors and subcontractors are required to be registered in the federal System for Award Management (SAM) and may not be debarred from doing business with the federal government. The successful respondent will be required to comply with all applicable federal regulations, including those outlined in Exhibit A attached herein.

## SCHEDULE OF EVENTS

Listed below is the tentative schedule of events associated with this project:

Date	Event
Friday, July 26, 2024	Invitation to Bid Released
Wednesday, August 14, 2024	Non-Mandatory Pre-Bid Conference 1:30 p.m.
Wednesday August 28, 2024	Deadline for Questions End 5:00 p.m.
Wednesday, September 4, 2024	Bids will be Opening 1:30 p.m.
Wednesday, September 25, 2024	Anticipated Contract Award
October 2024 (TBD)	Notice To Proceed / Commencement of Work
October - November 2024 (TBD)	Pre-Construction Meeting
January 2026	Project Completion

### ARTICLE 1 - INSTRUCTIONS TO BIDDERS

These instructions constitute an integral part of the Bid, and any Bidder agrees that submittal of a Bid constitutes acknowledgement and acceptance of its obligation to adhere to these instructions, which are to be incorporated into and considered part of any Contract the Bidder ultimately executes with the Owner.

- 1.01 Defined Terms: Terms used in these Instructions to Bidders have the meanings indicated in the Standard General Conditions of the Construction Contract Documents.
- 1.02 Copies of Bid Documents: Complete sets of Bidding Documents shall be used in preparing Bids; Owner does not assume any responsibility for errors or misinterpretations resulting from the use of incomplete sets of Bidding Documents.
- 1.03 Cost Incurred by Bidders: Bidders are responsible for all costs associated with the preparation, development and submittal of a Bid in response to this Invitation for Bids. It is expressly understood that no Bidder may seek any reimbursement from the Owner for any expenses, costs, or fees.
- 1.04 Conflict of Interest: Bidders shall promptly notify the Owner in writing of all potential conflicts of interest for any prospective business association, interest, or other circumstance, which may influence or appear to influence the Bidders judgement or quality of services being provided hereunder. Such written notification shall identify the prospective business association, interest, or circumstance, the nature of work that such person may undertake, and request an opinion of the Owner as to whether the association, interest, or circumstance would, in the opinion of the Owner, constitute a conflict of interest. By submitting the Bid, the Bidder certifies that it has no conflict of interest with any employees, agent, elected official or officer of the Owner or any other conflict as may be set forth herein.
- 1.06 Collusion: More than one Bid from an individual business, business partnership, corporation, association or related parties under the same or different names will not be considered. If the Owner believes that collusion exists among Bidders, all Bids from the suspected business will be rejected. "Related parties" means Bidders or the principals

thereof, which have a direct or indirect ownership or profit-sharing interest in another business. All bidders shall include the Non-Collison Form attached herein with their bid.

- 1.07 Specifications Limiting Competition: Bidders may comment on any specification or requirement contained within the Bid which they feel limits competition in the selection of Bid to perform the services herein defined. Protests shall be in be detailed in writing and submitted to the owner.
- 1.08 Qualifications of Bidders: All Bidders must be qualified to provide the services requested in the Bid documents. Proof of qualifications must be provided by completing and submitting the Contractor Qualifications Form attached herein. All licenses and/or certifications must be valid and current on the date Bids are submitted.
- A. A Bidder’s failure to submit required qualification and reference information may be disqualified from receiving an award of the Contract.
  - B. No requirement in the bid documents to submit information will prevent the right of Owner to seek additional pertinent information regarding Bidder’s qualifications.
  - C. The Bidder must complete and include with its bid the Contractor Reference Form attached herein. Contractor shall provide a minimum of three (3) references for related projects completed within the last five (5) years.
- 1.09 Disadvantaged Business Opportunity: In accordance with Title VI of the Civil Rights Act of 1964, (78 Stat. 252, 42 USC 2000d to 2000d-4) and the Regulations, hereby notifies all bidders that it will affirmatively ensure that in any contract entered into pursuant to this advertisement, disadvantaged business enterprises will be afforded full and fair opportunity to submit bids in response to this invitation and will not be discriminated against on the grounds of race, color, or national origin in consideration for an award.

## **ARTICLE 2 - EXAMINATION OF WORK SITE**

Project Location: The Project is located in the City of North Augusta’s Wastewater Collection System service area. Wastewater pipelines are primarily located within publicly maintained street rights of way, along pedestrian walking trails and utility maintained easements.

- 2.01 It is recommended that the bidder conduct a thorough, alert visual examination of the Work Site and adjacent areas, and become familiar with and satisfy itself as to the general, local, and Site conditions that may affect cost, progress, and performance of the Work.
- 2.02 Mandatory Work Site Visit: All bidders are required to visit the work site during normal work hours Monday – Friday from 8:00 a.m. – 5:00 p.m. Bidders can schedule a site visit by contacting [jsutton@northaugustasc.gov](mailto:jsutton@northaugustasc.gov) or by calling (803) 441-4240.
- A. Bids will be rejected from bidder’s who fail to visit the work site.
  - B. Site visits will be governed by the Owner’s safety program.
  - C. Bidder is not required to conduct any subsurface testing.

### **ARTICLE 3 - BID SUBMITTAL REQUIREMENTS**

The following items are required to be included as part of the bid submittal. Failure to include any of these items may result in the bid being rejected:

- a) Bid Form;
- b) Addendum Form;
- c) Contractor Qualifications Form;
- d) Contractor Reference Form;
- e) List of Subcontractors;
- f) Bid Security Bond;
- g) Non Collusion Form;
- h) Debarment Statement Form;
- i) EEOC Form;
- j) SAM Certification Form;
- k) Lobbying Certification

### **ARTICLE 4 - PRE-BID CONFERENCE**

A non-mandatory attendance Pre-Bid Conference will be held on Wednesday August 14, 2024 at 1:30 p.m. at the City of North Augusta Operations Facility located at 61 Claypit Road North Augusta, South Carolina 29841. The Owner's representative will be present to discuss the Project. Bidders are encouraged to attend and participate in the conference.

### **ARTICLE 5 - INTERPRETATIONS AND ADDENDA**

Addenda may be issued to clarify, correct, supplement, or change the Bidding Documents. All questions about the meaning or intent of the Bidding Documents are to be submitted to [jsutton@northaugustasc.gov](mailto:jsutton@northaugustasc.gov)

5.01 Interpretations or clarifications considered necessary by Owner in response to such questions will be issued by Addenda delivered to all parties recorded as having received the Bidding Documents.

5.02 If it becomes necessary to revise any part of this Invitation to Bid, a written addendum will be issued. All addenda issued by the Owner will become part of the official Invitation to Bid. Each Bidder is responsible for incorporating all issued Addenda into their submitted Bid. Bidders shall acknowledge receipt of all issued addenda on the attached form herein in their bid package. Failure to acknowledge all issued addenda may result in a Bid being deemed non-responsive to the requirements of the Bid Documents. All questions submitted and their answers will be delivered to bidders by email and posted on the Owners website as an addendum to this Invitation to Bid.



Questions received after 5:00 p.m. Wednesday August 28, 2024 will not be answered. Only questions answered by Addenda will be binding. Oral and other interpretations or clarifications will be without legal effect.

#### **ARTICLE 6 - BID SECURITY**

A Bid must be accompanied by Bid security made payable to Owner in an amount of [5%] percent of Bidder's maximum Bid price (determined by adding the base bid and any alternates) and in the form of a certified check, bank money order, or a surety bid bond. Failure to submit the Bid bond shall be cause for rejection of the Bid.

- 6.01 The Bid security of the apparent Successful Bidder will be retained until Owner awards the contract to such Bidder, and such Bidder has executed the Contract Documents, furnished the required contract security, and met the other conditions of the Notice of Award, whereupon the Bid security will be released.
- 6.02 If the Successful Bidder fails to execute and deliver the Contract Documents and furnish the required contract security within 15 days after the Notice of Award, Owner may consider Bidder to be in default, annul the Notice of Award, and the Bid security of that Bidder will be forfeited. Such forfeiture shall be Owner's exclusive remedy if Bidder defaults.
- 6.03 The Bid security of other Bidders that Owner believes to have a reasonable chance of receiving the award may be retained by Owner until the earlier of seven days after the Effective Date of the Contract or 90 days after the Bid opening, whereupon Bid security furnished by such Bidders will be released.
- 6.04 Bid security of other Bidders that Owner believes do not have a reasonable chance receiving the award will be released within seven days after the Bid opening.

#### **ARTICLE 7 - CONTRACT TIMES**

- 7.01 Bidder agrees that the Work will be substantially complete on or before Friday January 9, 2026, and will be completed and ready for final payment on or before Friday January 30, 2026.

#### **ARTICLE 8 - LIQUIDATED DAMAGES**

Provisions for liquidated damages, if any, for failure to timely attain a Milestone, Substantial Completion, or completion of the Work in readiness for final payment, are set forth herein in Article 36.

#### **ARTICLE 9 - SUBSTITUE OR-EQUAL ITEMS**

The Contract for the Work, as awarded, will be on the basis of materials specified or described in the Bidding Documents, and those "or-equal" or substitute and materials subsequently approved by Owner prior to the submittal of Bids.

- 9.01 No item of material or equipment will be considered by Owner as an "or-equal" or substitute unless written request for approval has been submitted by Bidder and has been received by Owner at least 15 days prior to the date for receipt of Bids. The burden of proof of the merit of the proposed item is upon Bidder. Owner's decision of approval or

disapproval of a proposed item will be final. If Owner approves any such proposed item, such approval will be set forth in an Addendum issued to all prospective Bidders. Bidders shall not rely upon approvals made in any other manner.

#### **ARTICLE 10 - SUBCONTRACTORS**

The Successful Bidder shall within five days after Bid opening, submit to Owner a list of the Subcontractors or Suppliers proposed for portions of the Work.

- 10.01 If requested by Owner, such list shall be accompanied by an experience statement with pertinent information regarding similar projects and other evidence of qualification for each such Subcontractor. If Owner after due investigation, has reasonable objection to any proposed Subcontractor, Owner may, before the Notice of Award is given, request apparent Successful Bidder to submit an acceptable substitute, in which case apparent Successful Bidder shall submit a substitute.
- 10.02 If apparent Successful Bidder declines to make any such substitution, Owner may award the Contract to the next lowest Bidder that proposes to use acceptable Subcontractors. Declining to make requested substitutions will constitute grounds for forfeiture of the Bid security of any Bidder. Any Subcontractor so listed and against which Owner makes no written objection prior to the giving of the Notice of Award will be deemed acceptable to Owner.

#### **ARTICLE 11 - PREPERATION OF BID**

- 11.01 All blanks on the Bid Form attached herein shall be completed in ink. Erasures or alterations shall be initialed in ink by the person signing the Bid Form.
- 11.01 A Bid price shall be indicated for each section, Bid item, alternate and unit price items listed therein.
- 11.02 A Bid by a corporation shall be executed in the corporate name by a corporate officer (whose title must appear under the signature), accompanied by evidence of authority to sign. The corporate address and state of incorporation shall be shown.
- 11.03 A Bid by a limited liability company shall be executed in the name of the firm by a member or other authorized person and accompanied by evidence of authority to sign. The state of formation of the firm and the official address of the firm shall be shown.
- 11.04 A Bid by an individual shall show the Bidder's name and official address.
- 11.05 A Bid by a joint venture shall be executed by an authorized representative of each joint venture in the manner indicated on the Bid Form. The official address of the joint venture shall be shown.
- 11.06 The Bid shall contain an acknowledgment of receipt of all Addenda, the numbers of which shall be filled in on the Addenda Form.

## **ARTICLE 12 - SUBMITTAL OF BID**

- 12.01 A Bid shall be received no later than the date and time prescribed and at the place indicated in the advertisement or invitation to bid and shall be enclosed in a plainly marked package and clearly labeled with the Project title, the name and address of Bidder, and shall be accompanied by the Bid security and other required documents. If a Bid is sent by mail or other delivery system, the sealed envelope containing the Bid shall be enclosed in a separate package plainly marked on the outside with the notation "BID ENCLOSED."
- 12.02 Bids received after the date and time prescribed for the opening of bids, or not submitted at the correct location or in the designated manner, will not be accepted and will be returned to the Bidder unopened.

## **ARTICLE 13 - MODIFICATION WITHDRAWAL OF BID**

A Bid may be withdrawn by an appropriate document duly executed in the same manner that a Bid must be executed and delivered to the place where Bids are to be submitted prior to the date and time for the opening of Bids. Upon receipt of such notice, the unopened Bid will be returned to the Bidder. If a Bidder wishes to modify its Bid prior to Bid opening, Bidder must withdraw its initial Bid and submit a new Bid prior to the date and time for the opening of Bids.

## **ARTICLE 14 – OPENING OF BIDS**

An abstract of the amounts of the base Bids and alternates, if any, will be made available to Bidders after the opening of Bids.

## **ARTICLE 15 - EVALUATION OF BIDS**

Owner reserves the right to reject any or all Bids, including without limitation, nonconforming, nonresponsive, unbalanced, or conditional Bids. Owner will reject any Bid that Owner finds, after reasonable inquiry and evaluation, to not be responsible. If Bidder purports to add terms or conditions to its Bid, takes exception to any provision of the Bidding Documents, or attempts to alter the contents of the Contract Documents for purposes of the Bid, then the Owner will reject the Bid as nonresponsive; provided that Owner also reserves the right to waive all minor informalities not involving price, time, or changes in the Work.

- 15.01 In evaluating Bids, Owner will consider whether or not the Bids comply with the prescribed requirements, and such alternates, unit prices, and other data, as may be requested in the Bid Form or prior to the Notice of Award.
- 15.02 In the comparison of Bids, alternates will be applied in the same order of priority as listed in the Bid Form. To determine the Bid prices for purposes of comparison, Owner shall announce to all bidders a "Base Bid plus alternates" budget after receiving all Bids, but prior to opening them. For comparison purposes alternates will be accepted, following the order of priority established in the Bid Form, until doing so would cause the budget to be exceeded. After determination of the Successful Bidder based on this comparative process and on the responsiveness, responsibility, and other factors set forth in these Instructions, the award may be made to said Successful Bidder on its base Bid and any combination of its additive alternate Bids for which Owner determines funds will be available at the time of award.

- 15.03 For the determination of the apparent low Bidder when unit price bids are submitted, Bids will be compared on the basis of the total of products, of the estimated quantity of each item and unit price Bid for that item, together with any lump sum items.
- 15.04 In evaluating whether a Bidder is responsible, Owner will consider the qualifications of the Bidder and may consider the qualifications and experience of Subcontractors.
- 15.05 Owner may conduct such investigations as Owner deems necessary to establish the qualifications and financial ability of Bidders and any proposed Subcontractors.
- 15.06 After determination of the Successful Bidder based on the responsiveness, responsibility, and other factors set forth in these Instructions, the award may be made to said Successful Bidder on its base Bid and any combination of its additive alternate Bids for which Owner determines funds will be available at the time of award.
- 15.07 The award of the contract will be made to the lowest, responsive, responsible, and Qualified Bidder. The Notice of Intent to Award the Contract will be posted on the Owners website and emailed to all respondents.
- 15.08 Protest of Award: Any Bidder who is adversely affected or aggrieved by the Owner Notice of Intent to Award to another Bidder shall have three (3) days after Notice of Intent to Award to submit to the Owner a written protest of the award. The written protest shall specify the grounds upon which the protest is base. The Owner will not accept protests submitted after the time period established.

#### **ARTICLE 16 – BONDS AND INSURANCE**

- 16.01 Article 28 of the Standard General Conditions of the Construction Contract, sets forth Owner’s requirements as to performance and payment bonds and insurance. When the Successful Bidder delivers the Agreement (executed by Successful Bidder) to Owner, it shall be accompanied by required bonds and insurance documentation.

#### **ARTICLE 17 - BIDDER ACKNOWLEDGEMENTS**

- 17.01 Bidder accepts all of the terms and conditions herein and This Bid will remain subject to acceptance for 90 days after the Bid opening, or for such longer period of time that Bidder may agree to in writing upon request of Owner.
- 17.01 In submitting this Bid, Bidder represents that:
- A. Bidder has examined and carefully studied the Bidding Documents, and any data and reference items identified in the Bidding Documents, and receipt of any addenda.
  - B. Bidder has visited the Site, conducted a thorough examination of the Site and adjacent areas, and become familiar with and satisfied itself as to the general, local, and Site conditions that may affect cost, progress, and performance of the Work.
  - C. Bidder is familiar with and has satisfied itself as to all Laws and Regulations that may affect cost, progress, and performance of the Work.
  - D. Bidder agrees that no further examinations, investigations, studies, or data are necessary for the determination of this Bid for performance of the Work at the price

bid and within the times required, and in accordance with the other terms and conditions of the Bidding Documents.

- E. Bidder has given Owner written notice of all conflicts, errors, ambiguities, or discrepancies that Bidder has discovered in the Bidding Documents, and confirms that the written resolution thereof by Owner's representative is acceptable to Bidder.
- F. The submission of this Bid constitutes an incontrovertible representation by Bidder that Bidder has complied with every requirement of this Article, and that without exception the Bid and all prices in the Bid are premised upon performing and furnishing the Work required by the Bidding Documents.

#### **ARTICLE 18 - BASIS OF BID**

- 18.01 Bidders shall submit a Bid on a unit price basis for each item of Work listed in the unit price section of the Bid Form.
- 18.0 The "Bid Price" for each unit price Bid item will be the product of the Estimated Quantity for the item and the corresponding Bid Unit Price offered by the Bidder. The total of all unit price Bid items will be the sum of these Lump Sum Bid Prices; such total will be used by Owner for Bid comparison purposes.
- 18.03 The price for each alternate will be the amount added to or deleted from the base Bid if Owner selects the alternate.

## **ARTICLE 19 - MEASURE OF PAYMENT**

Payment for the Bid items listed in the bid form shall include the following:

Bid Item No. 1: Payment shall be linear feet (LF) unit price to furnish all materials, equipment, labor and any incidental required to install 18-inch Cured-In-Place Pipe (CIPP) 9.0 mm Liner.

Bid Item No. 2: Payment shall be linear feet (LF) unit price to furnish all materials, equipment, labor and any incidental required to install 18-inch Cured-In-Place Pipe (CIPP) 12.0 mm Liner.

Bid Item No. 3: Payment shall be linear feet (LF) unit price to furnish all materials, equipment, labor and any incidental required to install 18-inch Cured-In-Place Pipe (CIPP) 13.5 mm Liner.

Bid Item No. 4: Payment shall be Linear Feet (LF) unit price to furnish all materials, equipment, labor and any incidental required to Pre-Post and Post CCTV inspect 18-inch pipeline and clean pipeline prior to Cured-In-Pipe-Pipe (CIPP) Liner installation.

Bid Item No 5: Payment shall be linear feet (LF) unit price to furnish all materials, equipment, labor and any incidental required to install 21-inch Cured-In-Place Pipe (CIPP) 12.0 mm Liner.

Bid Item No. 6: Payment shall be Linear Feet (LF) unit price to furnish all materials, equipment, labor and any incidental required to Pre-Post and Post CCTV inspect 21-inch pipeline and clean pipeline prior to Cured-In-Pipe-Pipe (CIPP) Liner installation.

Bid Item No. 7: Payment shall be Vertical Feet (VF) price to furnishing all materials, equipment, labor and any incidental required to reline 48-inch brick manholes.

Bid Item No. 8: Payment shall be Vertical Feet (VF) price to furnishing all materials, equipment, labor and any incidental required to repair brick, inverts, benches, walls and chimney.

Bid Item No. 9: Payment shall be per Each (EA) unit price to furnishing all materials, equipment, labor and any incidental required to replace existing manhole frames and covers located in grass, non-paved surface areas.

Bid Item No. 10: Payment shall be per each (EA) unit price to furnish all materials, equipment, labor and any incidental required to reinstate service lateral connection.

Bid Item No. 11: Payment shall be Lump Sum (LS) unit price to furnish all materials, equipment, labor and any incidental required to temporary by-pass wastewater flow during CCTV pipe inspection and CIPP liner installation.

Bid Item No. 12: Payment shall be lump sum (LS) price to obtain all required insurance, bonds and incidental work necessary to properly mobilize labor, equipment and materials to and from the work site.

Bid Item No. 13: Payment shall be lump sum (LS) unit price to furnish all labor, equipment required to install and maintain all temporary traffic and pedestrian control devices to perform pipeline and manhole work within right of ways and/or easements

Project Number: 2024-07-4290  
SCIIP Grant Number: A-23-C145

**ADDENDUM FORM**

Bidder has examined copies of all the Bidding Documents and of the following Addenda (receipt of all which is hereby acknowledged):

No. \_\_\_\_\_ Dated \_\_\_\_\_

No. \_\_\_\_\_ Dated \_\_\_\_\_

No. \_\_\_\_\_ Dated \_\_\_\_\_

No. \_\_\_\_\_ Dated \_\_\_\_\_

Bid Submittal Date: \_\_\_\_\_

Business Name: \_\_\_\_\_

Business Address: \_\_\_\_\_

Business Telephone Number: \_\_\_\_\_

Email Address: \_\_\_\_\_

Authorized Signature: \_\_\_\_\_

Print Name: \_\_\_\_\_

**ARTICLE 20 - BID FORM**

Project Number: 2024-07-4290  
 SCIIP Grant Number: A-23-C145

The final Contract price will be subject to adjustment according to final measured quantities, and the unit prices in the Bid will apply to such final quantities. The Owner reserves the right to reduce the amount of work that exceeds project funding.

Item No.	Item	Unit	Quantity	Unit Price	Total Price
1	18" Diameter Cured-In-Place-Pipe Liner 9.0 mm	LF	20,105		
2	18" Diameter Cured-In-Place-Pipe Liner 12.0 mm	LF	3,635		
3	18" Diameter Cured-In-Place-Pipe Liner 13.5 mm	LF	1,851		
4	18" Diameter Pipe CCTV Inspections & Light Cleaning	LF	25,591		
5	21" Diameter Cured-In-Place-Pipe Lining 12.0 mm	LF	3,642		
6	21" Diameter Pipe CCTV Inspections & Light Cleaning	LF	3,642		
7	48" Manhole Cementitious Relining (133 Manholes)	VF	1,197		
8	Manhole Repair (Inverts, Benches Walls and Chimney	EA	100		
9	Replace Manhole Frame & Cover	EA	80		
10	CIPP Restore Lateral Service Connection	EA	8		
11	Temporary By-Pass Pumping	LS	34,134		
12	Mobilization (Max 3% of Total Construction Cost)	LS	1		
13	Traffic & Pedestrian Control	LS	1		
				<b>BASE BID TOTAL</b>	

The undersigned Bidder proposes and agrees, if this Bid is accepted, to enter into an agreement with Owner in the form included in the Contract Documents to perform and furnish all Work as specified or indicated in the Contract Documents within the specified time and for the amount indicated in this Bid and in accordance with the terms and conditions of the Contract Documents.

Bid Submittal Date: \_\_\_\_\_

Business Name: \_\_\_\_\_

Business Address: \_\_\_\_\_

Authorized Signature: \_\_\_\_\_

Print Name: \_\_\_\_\_

Title: \_\_\_\_\_



## **ARTICLE 21 – SIGNING OF AGREEMENT**

When Owner issues a Notice of Award to the Successful Bidder, it shall be accompanied by the unexecuted counterparts of the Agreement along with the other Contract Documents as identified in the Agreement. Within 10 days thereafter, Successful Bidder shall execute and deliver the required number of counterparts of the Agreement, bonds insurance and any other documents required shall be delivered to Owner. Within ten days thereafter, Owner shall deliver one fully executed counterpart of the Agreement to Successful Bidder, together with printed and electronic copies of the Contract Documents.

Project Number: 2024-07-4290  
SCIIP Grant Number: A-23-C145

**CONTRACTOR QUALIFICATIONS FORM**

Date: \_\_\_\_\_

Business Name: \_\_\_\_\_

Business Address: \_\_\_\_\_

Phone Number:: \_\_\_\_\_

Email Address: \_\_\_\_\_

Business Website: \_\_\_\_\_

Federal ID Number: \_\_\_\_\_

Number of Years in Business: \_\_\_\_\_

List all active Company/Contractor Licenses and Certifications below:

<b>License/Certification</b>	<b>Issued By:</b>	<b>Expiration Date</b>

Authorized Signature: \_\_\_\_\_

Print Name: \_\_\_\_\_

Title: \_\_\_\_\_

Project Number: 2024-07-4290  
SCIIP Grant Number: A-23-C145

**CONTRACTOR REFERENCES FORM**

This form must be submitted with the Bid. Three ( 3 ) references of similar completed projects shall be provided by the Contractor. Please provide the name of project, overall contract value, description of work completed, along with contact information for the project’s owner.

**Project #1:**

Project Description: \_\_\_\_\_

Contact Name: \_\_\_\_\_

Address: \_\_\_\_\_

Phone Number: \_\_\_\_\_

**Project #2:**

Project Description: \_\_\_\_\_

Contact Name: \_\_\_\_\_

Address: \_\_\_\_\_

Phone Number: \_\_\_\_\_

**Project #3:**

Project Description: \_\_\_\_\_

Contact Name: \_\_\_\_\_

Address: \_\_\_\_\_

Phone Number: \_\_\_\_\_

Date: \_\_\_\_\_

Bidder/Business Address: \_\_\_\_\_

Authorized Signature: \_\_\_\_\_

Print Name: \_\_\_\_\_

Title: \_\_\_\_\_

Project Number: 2024-07-4290  
SCIIP Grant Number: A-23-C145

**LIST OF SUBCONTRACTORS**

In the space below, the Bidder shall list all proposed Subcontractors and their addresses for approval by the Owner. The Bidder shall also describe that portion of the work they propose to subcontract to each Subcontractor listed.

Business Name:

---

Business Address:

---

Work to be Performed:

---

Business Name:

---

Business Address:

---

Work to be Performed:

---

Date: \_\_\_\_\_

Business Name: \_\_\_\_\_

Authorized Signature: \_\_\_\_\_

Print Name: \_\_\_\_\_

Title: \_\_\_\_\_

Project Number: 2024-07-4290  
SCIIP Grant Number: A-23-C145

**AFFIDAVIT OF NONCOLLUSION**

**KNOW ALL PERSONS BY THESE PRESENTS**, that, \_\_\_\_\_  
*Name of Contractor*

as a Bidder on the above-named public improvement project, does hereby certify that no officer, agent, or employee of the State, County, or City who has a pecuniary interest in the Bid has participated in the Contract negotiations on the part of the City, that the Bid is made in good faith without fraud, collusion, or connection of any kind with any other Bidder, and that the Bidder is competing solely on its own behalf without connection with, or obligation to, any undisclosed person or firm.

**IN WITNESS WHEREOF**, the undersigned has duly authorized the execution of this document by the name and signature indicated below. If Contractor is an entity (Inc., LLC, LLP, Co. etc.) or principal, their representative, by signing below, certifies that such representative is authorized by the entity or principal to execute this document.

Dated this \_\_\_\_\_ day of \_\_\_\_\_, 2024.

\_\_\_\_\_  
*Signature*

*Title*

Personally appeared before me this \_\_\_\_\_ da \_\_\_\_\_ and has acknowledged the foregoing instrument to be his or her voluntary act and deed.

\_\_\_\_\_  
NOTARY PUBLIC

My Commission expires: \_\_\_\_\_

**DEBARRMENT AND SUSPENSION CERTIFICATION**

Project Number: 2024-07-4290  
SCIIP Grant Number: A-23-C145

All contractors and subcontractors are required to be registered in the Federal System for Award Management (SAM) and may not be debarred from doing business with the federal government. Contractors and Subcontractors shall maintain an active registration with SAM throughout the Contract period.

Date: \_\_\_\_\_

SAMS Number: \_\_\_\_\_

Business Name: \_\_\_\_\_

Business Address: \_\_\_\_\_

Business Telephone Number: \_\_\_\_\_

Authorized Signature: \_\_\_\_\_

Print Name: \_\_\_\_\_

Title: \_\_\_\_\_

# CURED-IN-PLACE PIPE TECHNICAL SPECIFICATIONS

## Scope of Work

The Contractor shall provide furnish all labor, materials and equipment required to install Cured-In-Place Pipe (CIPP) lining and structurally rehabilitate approximately 25,951 linear feet of 18" Clay pipe and approximately 3,642 linear feet of 21" Clay pipe. The work includes but not limited to pre-pipe cleaning, pre-televising pipe inspections, post-televising pipe inspections, wastewater flow by-passing, and traffic control.

### 1.01 Project Location

The Project is located in the City of North Augusta's Wastewater Collection System service area. Wastewater pipelines are primarily located within publicly maintained street rights of way, along pedestrian walking trails and utility maintained easements

### 1.02 General

The specifications include minimum requirements for the rehabilitation of wastewater pipelines by the insertion CIPP within the existing pipeline. Omission of a specific item or component part of a system obviously necessary for the proper functioning of the system will not relieve the Contractor of the responsibility of furnishing the item as part of the work at no additional cost to the Owner.

1.03 The rehabilitation of pipeline shall be done by the installation of a resin-impregnated flexible tube which, when cured, shall be continuous and tight fitting throughout the entire length of pipe from manhole to manhole.

### 1.04 Qualifications

The personnel including the superintendent, the foreman and the lead crew personnel for the CCTV inspection, resin application, the CIPP liner installation, liner curing and the robotic service reconnections must have a minimum of three (3) years of total experience with the CIPP technology proposed for this contract and must have demonstrated competency and experience to perform the scope of work contained in this contract.

### 1.05 Pipe Liner

A. The felt material shall be manufactured by companies specializing in felt production for CIPP. The felt material manufacturer and facility shall not change during construction unless specifically approved by the Owner in writing.

B. The CIPP shall be designed for a life of 50 years or greater.

C. The Cured-In-Place-Pipe (CIPP) liner shall be composed of tubing material consisting of one or more layers of a flexible non-woven felt fabric, felt/fiberglass or fiberglass and meet the requirements of ASTM F1216, ASTM F1743, ASTM D5813 and ASTM F2019. The liner material and resin shall be completely compatible. The inside and/or outside layer of the tube shall be coated with an impermeable material compatible with the resin and fabric. The liner resin system shall be cured by water, steam or UV.

D. The CIPP shall be fabricated to a size that will tightly fit the pipe being rehabilitated

after being installed and cured. The liner shall be capable of fitting into irregularly shaped pipe sections and through bends and dips within the pipeline. Allowance for longitudinal and circumferential expansion shall be taken into account when sizing and installing the liner.

- E. The Contractor shall verify all pipe dimensions in the field prior to fabrication of the liner. Field measurements shall be used to ensure maximum closure between the new liner and the existing sewer pipe.
- F. The length of the liner shall be the length deemed necessary by the Contractor to effectively carry out the insertion of the liner and sealing of the liner at the outlet and inlet manholes. The Contractor shall verify the required length of liner in the field prior to fabrication of the liner.
- G. The cured liner shall have the following minimum structural properties:
  - Flexural Strength of 4,500 psi per ASTM D790
  - Flexural Modulus of 250,000 psi per ASTM D790
  - Tensile Strength of 3,000 psi per ASTM D638
- H. The minimum installed, cured pipe liner thickness required are listed in Table-1 below:

Table 1 Minimum Finished Liner Thickness			
Pipe Diameter	Pipe Invert Depth up to 10-Feet	Pipe Invert Depth 10-15 Feet	Pipe Invert Depth Over 15 Feet
15"	7.5 mm	9.0 mm	10.5 mm
18"	9.0 mm	12.0 mm	13.5 mm
21"	10.5 mm	13.5 mm	15.0 mm

- I. The Contractor shall verify the liner thicknesses included in Table-1 for accuracy and variations required to accommodate the selected process and structural requirements. No additional compensation will be allowed for these variations. Any proposed adjustments to the liner wall thickness or installation procedures shall be submitted by the Contractor to the Owner for approval including design criteria, calculations, and information required to ensure the structural integrity and hydraulic capacity of the proposed liner materials.



#### 1.06 Resin

- A. The resin shall be a corrosion resistant Premium polyester or vinyl resin catalyst system that when properly cured within the tube composite meets the requirements of ASTM F1216, ASTM F1743 or F2019-03.
- B. The resin cure schedules for the CIPP shall be submitted to the Owner for review. The curing process/schedules shall be approved by the resin manufacturer in writing. The cure schedules shall include specific information on stepping the temperature up to “cooking” temperatures, “cooking” temperatures and durations, and cool-down procedures, all to be approved in writing by the resin manufacturer.
- C. Copies of the shipment documents from the resin manufacturer shall be submitted to the Owner showing dates of shipment, the originating location and the receiving location.
- D. When cured, the CIPP shall form a continuous, tight-fitting, hard, impermeable liner, which is chemically resistant to any chemicals normally found in wastewater systems.
- E. The liner shall be chemically resistant to trace amounts of gasoline and other oil products commonly found in municipal sewerage and soils adjacent to the sewer pipe to be lined.

#### 1.07 Delivery, Storage and Shipping

Care shall be taken in shipping, handling and laying to avoid damaging the CIPP. Extra care shall be taken during cold weather construction. Any CIPP damaged in shipment shall be replaced as directed by the Owner. Any CIPP showing a split or tear or has been mishandled shall be marked as rejected and removed at once from the work site.

#### 1.08 Pipe Cleaning

- A. The Contractor shall provide all labor, materials, equipment, and supervision necessary for the proper preparatory cleaning of the designated wastewater pipelines prior to their internal inspection by closed-circuit television and rehabilitation by the CIPP lining process.
- B. The designated pipeline sections shall be cleaned using mechanically powered, hydraulically propelled, or high velocity cleaning equipment. The equipment selected for cleaning, shall be capable of removing dirt, grease, rocks, sand, roots, and other deleterious materials and obstructions from the designated pipelines.
- C. For each pipe segment accurate and legible records of the cleaning operation shall be kept on file by the Contractor. Two copies of the original record shall be furnished to the Owner at the end of each week’s operations. The records shall show, the manhole number, the amount of debris removed from each segment and the pipe diameter and length of each pipe segment.

#### 1.09 Material Removal

All sand and other solid or semi-solid material resulting from the cleaning operation shall be removed at the downstream manhole of the section being cleaned utilizing screens,

vacuum trucks and other appropriate equipment intended for such purposes.

#### 1.10 Disposal of Materials

All solids shall be removed at the downstream manhole of the section being cleaned. Collected solids shall be removed from the site and properly disposed of at the Owners expense and approved location.

#### 1.11 Internal Pipe Inspections

- A. The Contractor shall furnish all necessary labor, materials, supervision, and equipment to satisfactorily inspect the conditions of all wastewater pipelines that have been designated for Closed Circuit Televising Video pipe inspection (CCTV), prior to CIPP lining.
- B. After the pipes are completely cleaned, the pipes shall be inspected using CCTV equipment. The purposes of the CCTV inspections are to verify that the pipes have been thoroughly cleaned, to document the the locations of service connections and to confirm that the lining can be properly installed and cured.
- C. Upon completion of the cleaning and television inspection work, the Contractor shall submit one copy of the final CCTV inspection videos to the Owner. The videos shall be clearly labeled as to their contents. The final inspection shall mean that the pipe has been completely cleaned and the inspection is complete from manhole to manhole.

#### 1.12 Liner Installation

- A. The Contractor shall furnish and install the CIPP lining in the full length of pipe. Where possible, the Contractor shall line multiple pipe segments at one time as determined by the Contractor. When this is done, the top one-half of the liner in the intermediate manhole shall be neatly removed, and the void behind the liner pipe shall be filled with non-shrink grout. The manhole bench shall be reconstructed if necessary to make a smooth transition at no additional cost to the Owner.
- B. There shall be no leakage of groundwater into the manhole between the CIPP and existing pipe and between the existing pipe and manhole wall.
- C. Installation reports shall be generated for each segment of liner installed. The reports shall document installation, including manhole numbers, street names, location, project number, date, time, temperature, curing temperature, curing time, liner thickness, etc. A sample report shall be submitted to the Owner for approval prior to installing any lining. The reports shall be submitted to the Owner prior to requesting payment.

#### 1.13 Reconnection of Existing Service Laterals

- A. The Contractor shall maintain two working lateral reinstatement cutters at the job site at all times. Lining work shall not commence if the Contractor does not have the required number of working cutters on site. No additional time or compensation shall be awarded for Contractor's failure to comply with this requirement.

- B. The Contractor shall reopen all existing lateral service connections in each length of sewer immediately following installation of the liner.
- C. The Contractor shall reopen service connections from inside the pipe by means of a remote controlled, video assisted cutting device appropriate for the liner material and the CIPP. Each active service connection shall be cut completely open at a minimum of 95% of the service pipe diameter and shall have smooth edges with no protruding material capable of hindering flow or catching and holding solids contained in the flow stream. The Contractor shall not overcut the lateral connection. Excess resin shall be removed from the lateral.
- D. All coupons from lateral reinstatement shall be removed at the downstream manhole and shall not be allowed to enter the sanitary sewer system.

#### 1.14 Cool Down

- A. Temperatures and curing data shall be monitored and recorded, by the Contractor, throughout the installation process to ensure that each phase of the process is achieved as approved in accordance with the CIPP System manufacturer's recommendations.
- B. Water temperature shall be below 120 degrees before being released into the wastewater stream.

#### 1.15 Post-Rehabilitation Television Inspection

Following installation of the CIPP, the Contractor shall conduct a final CCTV post-inspection of the completed work to verify that the liner installation is acceptable. The CCTV inspections must clearly show the installed CIPP from manhole to manhole and each service connection to demonstrate that the installed CIPP meets all requirements.

Payment will not be made for any pipe lining until the Owner has reviewed and approved the final videos.

#### 1.16 Quality Control

No change of material, design values, or procedures may be made during the course of the Work without the prior written approval of the Owner.

- A. The Contractor shall inspect each liner at delivery to assure the liner is homogeneous throughout, uniform in color, free of cracks, holes, splits foreign materials, blisters, or other type defects in the CIPP lining.
- B. The Contractor shall have a Procedure in place that will allow the Owner to monitor the resin impregnation process.
- C. For every pipe segment that is lined (pipe segment is defined as the sewer between two manholes), the Contractor shall remove one restrained sample of the installed liner for testing of installed CIPP. The CIPP testing shall include determining flexural strength, flexural modulus, tensile strength and thickness of each sample.
- D. The Contractor shall select the independent testing laboratory and shall pay the

laboratory for all tests.

- E. The testing laboratory shall specify the dimensions for the samples.
- F. The Contractor shall label all samples including writing on the samples the pipe segment number they were taken from and the date.
- G. The Owner will forward the samples to the testing laboratory The Owner will copy the contractor on all submittals to the testing laboratory. The testing laboratory shall submit all test results directly back to the Owner with a copy to the Contractor.
- H. The tests shall be used to verify that the installed CIPP meets these specifications. CIPP thickness shall be measured in accordance with ASTM D5813. Flexural properties shall be determined per ASTM D790. Tensile strength shall be determined per ASTM D638.
- I. Any lining that does not meet the specified installed strength and/or thickness requirements, regardless of the amount below the specified requirements, shall be corrected by the Contractor in a manner Approved by the Owner at no additional cost to the Owner.

#### 1.17 References

The following documents form a part of this specification to the extent stated herein and shall be the latest editions thereof. Where differences exist between codes and standards, the requirements of these specifications shall apply.

- ASTM - F1216 Standard Practice for Rehabilitation of Existing Pipelines and Conduits by the Inversion and Curing of a Resin-Impregnated tube.
- ASTM – F1743 Standard Practice for Rehabilitation of Existing Pipelines and Conduits by the Pull in and Inflate and Curing of Resin-Impregnated Tube
- ASTM – D 543 Standard Practice for Evaluating the Résistance of Plastics
- ASTM - F2019 Standard Practice for Rehabilitation of Existing Pipelines and Coby Pulled in Place Installation.
- ASTM - D790 Standard Test Methods for Flexural Properties of Un-reinforced and Reinforced Plastics and Electrical Insulating Materials
- ASTM - D638 Standard Test Method for Tensile Properties of Plastics
  
- ASTM - D5813 Standard Specification for Cured-in Place Thermosetting Resin Sewer Pipe

#### 1.18 Submittals

- A. The submittals listed below shall be submitted prior to beginning construction:
  - 1) Independent third party certified laboratory test reports showing that the resin/liner combination to be used for this project meets the requirements for initial structural properties and chemical resistance in accordance with ASTM

F1216 and ASTM D790.

- 2) MSDS sheets for all materials to be provided for this project.
- 3) Fabric tube manufacturer and product components description.
- 4) Flexible membrane coating material data sheet including repair recommendations.
- 5) Raw resin manufacturer and product components description.
- 6) Manufacturers shipping and storage recommendations for all components of the CIPP system.
- 7) Description of the proposed wet-out procedure.
- 8) Manufacturer's recommended cure method for each diameter and thickness to be used in the project that shall include a detailed curing schedule for each segment.
- 9) Contractor's proposed installation schedule.
- 10) Contractor's detailed proposed method and procedures for installation.

B. The following documentation shall be submitted during construction:

- 1) Pre and Post CCTV Video Inspections & Written Reports
- 2) Wet-Out Report
- 3) Curing Log
- 4) CIPP Test Sample Report
- 5) Service Connection Report

#### 5.19 Warranty and Guarantee

A. All liner installations shall be warranted to be free from defects in materials and Workmanship for a period of three (3) years from the date of project acceptance. The required three (3) year guarantee covers all workmanship and construction and shall warranty that the liner shall not:

- 1) Impede flow and cause backups to the customer;
- 2) Collapse or separate from the wall;
- 3) Allow groundwater infiltration;
- 4) Allow root intrusion;
- 5) Allow soil migration into the main;
- 6) Experience material degradation;
- 7) Exhibit properties of improper curing;
- 8) Become unsealed at mainline to lateral connection; or

- 9) Any other defect inhibiting proper performance of the mainline or lateral.
- B. Any defect discovered during this three (3) year period shall be repaired within four (4) weeks for from the date of defect notification to the Contractor at no additional cost to the Owner.

# MANHOLE REHABILITATION SPECIFICATIONS

## Scope of Work

The Contractor shall provide furnish all labor, materials and equipment required to structurally rehabilitate 133 brick manholes with an approximate diameter of 48 inches The work includes but not limited to surface cleaning, removal of steps, bypass pumping, masonry work, ground water infiltration sealing, cementitious lining, manhole bench, channel and invert repairs, protective corrosion control coating and replacing the manhole frame and cover.

### 2.01 Project Location

The Project is located in the City of North Augusta's Wastewater Collection System service area. Wastewater pipelines are located within publicly maintained street rights of way, along pedestrian walking trails and utility maintained easements.

### 2.02 Minimum Requirements

The specifications below establish minimum required manhole rehabilitation standards. Omission of a specific item or component part of a system obviously necessary for the proper functioning of the system will not relieve the Contractor of the responsibility of furnishing the item as part of the work at no additional cost to the Owner.

### 2.03 Contractor Qualifications

The personnel including the superintendent, the foreman and the lead crew personnel for the must have a minimum of three (3) years of total experience with manhole rehabilitation utilizing cementitious technology proposed for this contract and must have demonstrated competency and experience to perform the scope of work contained in this contract. The name and experience of each lead individual performing work on this contract shall be submitted with the bid proposal.

### 2.04 References

The following standards form a part of this specification to the extent stated herein and shall be the latest editions thereof. Where differences exist between codes and standards, the requirements of these specifications shall apply.

- ASTM C109 Standard Test Method for Compressive Strength of Hydraulic Cement Mortars
- ASTM C596 Standard Test Method for Drying Shrinkage of Mortar Containing Hydraulic Cement
- ASTM C293 Standard Test Method for Flexural Strength of Concrete

### 2.05 Construction Photographs

The Contractor shall provide the Owner with preconstruction and post construction digital photo files of the manholes indicated for rehabilitation. Provide a list correlating the photo file number with manhole's approximate location. All photographs shall have sufficient detail of the interior of each manhole to reveal conditions of existing defects

and rehabilitated features.

#### 2.06 Product Handling

Care shall be taken in shipping, handling and placing to avoid damaging the products. Any product damaged in shipment, showing deterioration, or which has been exposed to any other adverse storage condition that may have caused damage, even though no such damage can be seen, shall be marked as rejected and removed at once from the work. While stored, the products shall be adequately packaged and protected. The products shall be stored in a manner as recommended by the manufacturer.

#### 2.07 Surface Preparation

- A. The floor and interior walls, manhole bench and invert shall be thoroughly cleaned and made free of all foreign materials including dirt, grit, roots, grease, sludge or other contaminants that may affect the performance and adhesion of the coating to the substrate.
- B. Prevent any foreign material from entering the adjoining pipes. Remove droppings of foreign and wall sealant materials before they harden on the bottom of the manhole.
- C. High pressure water blasting shall be used to clean free all foreign material within the manhole.
- D. All materials resulting from cleaning of the manhole shall be removed prior to application of cement-based coatings.
- E. All loose or defective brick and grout shall be removed to provide an even surface to application of coating.
- F. The Contractor shall remove all existing manhole steps/ladder rungs located in the existing manholes to be rehabilitated. In those manholes where the existing manhole steps/ladder rungs are removed, the holes shall be plugged and patched as shown on Detail Drawing Detail-1.

#### 2.08 Manhole Materials

- A. The cementitious material used shall be designed, manufactured, and intended for wastewater manhole rehabilitation and the specific application in which they are used.
- B. Contractor shall supply Owner with all product data, including manufacturer and brand name, laboratory test results to verify compressive strengths, and a list of similar projects in which the products were used.
- C. Material shall be specifically designed for placement by low pressure spraying to vertical and overhead surfaces of brick and masonry structures and shall restore structural integrity to interior manhole structures, and be specifically designed to prevent groundwater infiltration.
- D. The materials used in the cementitious lining systems shall be mixed on site in accordance with the manufacturer's recommendations.



- E. Material shall be resistant to hydrogen sulfide bacterial corrosion.
- F. The use of the product shall not result in the formation or production of any detrimental compounds or by-products at the wastewater treatment plant. The Contractor shall notify the Owner and identify any by-products produced as a result of installation operations, test and monitor levels and comply with all local waste discharge requirements.
- G. The cementitious lining shall cover the complete interior of the existing manhole including the benches. The lining shall effectively seal the interior surfaces of the manhole and prevent any penetration or leakage of groundwater infiltration.
- H. When cured, the cementitious lining shall form a continuous, tight-fitting, hard, impermeable surfacing that is chemically resistant to any chemicals or vapors normally found in wastewater collection systems.

2.09 Sealing, Plugging, and Patching Materials

A premixed non-shrink cement-based patching material consisting of hydraulic cement, graded silica aggregates, special plasticizing and accelerating agents, formulated for vertical or overhead use. It shall not contain chlorides, gypsums, plasters, iron particles, aluminum powder, or gas-forming agents or promote the corrosion of steel that it may come into contact with. Set time shall be less than 30 minutes. One-hour compressive strength. The product shall display the following properties:

Description	Strength (psi)		
	Day	7 Day	28 Day
Compressive Strength (ASTM C 109)	3,875	4,550	6,190
Flexural Strength (ASTM C 293)	-----	825	985
Shrinkage (ASTM C 596, Modified)	0.04 Percent @ 28 Days		

2.10 Groundwater Infiltration

Active leaks shall be stopped by injecting a chemical grout through the source to the outside of the manhole. The grout used shall be an acrylamide, acrylic or urethane gel and may require the addition of a shrink control agent, gel reinforcing agent and accelerator.

2.11 Manhole Invert

- A. Replacement or repairs shall be performed on all inverts. After blocking the flow through the manhole and thoroughly cleaning the invert, a fast-setting concrete mix shall be applied to the invert. The mix shall be troweled uniformly onto the invert.
- B. The finished invert shall be U-shaped uniform with pipe to full pipe diameter. Invert shall be at least 2 inches thick, and be smooth and free of ridges.

## 2.12 Manhole Bench

- A. The material to be sprayed on the bench shall form a gradual slope from the walls to the invert with the thickness at the edge of the invert being no less than 1 inch. The material shall be applied on the bench area in such a manner as to provide for proper drainage without ponding. The material shall be smooth steel trowel finish sloping from wall to invert as shown in Manhole Rehabilitation Detail Drawing-1.

## 2.13 Structural Repairs

Voids resulting from missing brick and mortar shall be repaired with new brick and mortar. All brick used for the cone repairs shall be designed for use in the construction of wastewater manholes capable of withstanding the corrosive environments associated with wastewater. High strength mortar suitable for use in the construction of manholes and capable of withstanding the corrosive environments associated wastewater shall be used in the cone repairs.

## 2.14 Spraying

- A. The material shall be pump for spray application. The method shall only be applied when the manhole is in a damp state, with no visible water dripping or running over the manhole walls.
- B. Spraying shall be performed by starting at the manhole invert and progressing up the wall to the corbel and chimney areas. The material shall be applied to allow a uniform thickness 1 inch for the cured liner on all vertical surfaces, such as the barrel sections. Minimum thickness on inclined sections, such as brick chimneys and cone sections, shall be one inch.
- C. Troweling of the material shall begin immediately following the spray application. Initial troweling shall be in an upward motion, to compress the material into voids and solidify the manhole wall. Proper precautions shall be taken not to over trowel the material.

## 2.15 Manhole Frame and Cover Replacement

The Contractor shall furnish all material, labor, tools, and equipment required to replace manhole frame and covers that are located along easements and right of way in grass/soil areas. Frames and covers shall not be replaced within paved roadways.

- A. Manhole frame and covers shall be made of Cast Iron and/or Ductile Iron and meet the dimension requirements as shown on Detail Drawing-2.
- B. All manhole frame and covers are located in grass (non-paved) surfaces along easements and highway-right-of-way.
- C. The Contractor shall remove and dispose of existing manhole frames and covers.
- D. Frames shall be set in full mortar bed. The mortar shall be struck smooth with the interior surface of the manhole and floated with a sponge float to a surface profile.
- E. It shall be the responsibility of the Contractor, at no additional cost to the Owner, to

repair any damage to the manhole caused by removal of the existing manhole frame.

2.16 Test

All manholes rehabilitated shall be tested using the vacuum test method.

- A. Vacuum testing manholes shall be performed after curing of linings.
- B. Any visible leakage or defect in the manhole before, during or after the test shall be repaired regardless of the test results.
- C. A vacuum of ten (10) inches of mercury (Hg) (5.0 psi) shall be drawn on the manhole, and the time shall be measured for the vacuum drop to nine (9) inches of mercury (HG) (4.5 psi). Manholes will be considered to have failed the air test if the time to drop one (1) inch of mercury is less than what is shown in the following table:

Vacuum Test Timetable		
Manhole Diameters		
Inches		
Depth-Feet	48 Inches	60 Inches
4	30 Sec.	30 Sec.
8	30 Sec.	30 Sec.
12	30 Sec.	39 Sec.
16	40 Sec.	52 Sec.
20	50 Sec.	65 Sec.

- D. If the manhole fails the vacuum test, the Contractor shall perform additional repairs, at no cost to the Owner, and repeat the test procedures until obtaining satisfactory results.
- E. After the manhole rehabilitation work has been completed, the Owner's Representative shall visually inspect the manhole. The finished surface shall be free of blisters, runs, sags or other indications of uneven lining thickness. The finished surface shall not have any evidence of visible leaks.

2.17 Cleanup

All debris and excess materials not incorporated into the permanent installation shall be removed by the Contractor. The debris and liquids are to be disposed of properly in accordance with all applicable laws. Hauling and disposal costs will be at the Contractor expense. The work area shall be left in a condition equal to or better than prior condition.

## 2.18 Submittals

The following submittals shall be submitted prior to beginning construction:

1. Product data, including manhole rehabilitation component, manufacturer, data sheets, ASTM references, material composition, manufacturer's recommended specifications, component physical properties and chemical resistance.
2. Manufacturer's recommended procedures for storing and handling materials, including Contractor's proposed method for complying to the storage and handling requirements.
3. Technical datasheet on each manhole rehabilitation component applied/installed, stating the expected longevity of the component in a wastewater environment. Data sheet shall be based on independent third- party tests.
4. Copies of independent testing performed in the rehabilitation component, indicating that the product meets the requirements of these specifications.
5. A complete and accurate record of all work performed, and all components installed for each manhole rehabilitated.
6. Manhole Images Pre and Post Work.

## 2.19 Warranty and Guarantee

- A. All manhole relining shall be warranted to be free from defects in materials and Workmanship for a period of three (3) years from the date of project acceptance. The required three (3) year guarantee covers all workmanship and construction and shall warranty that the relining shall not:
  - 1) Collapse or separate from the wall;
  - 2) Allow groundwater infiltration;
  - 3) Allow root intrusion;
  - 4) Allow soil migration into the main;
  - 5) Experience material degradation;
  - 6) Exhibit properties of improper curing.
- B. Any defect discovered during this three (3) year period shall be repaired within four (4) weeks for from the date of defect notification to the Contractor at no additional cost to the Owner.

# MANHOLE REHABILITATION DETAIL DRAWING-1

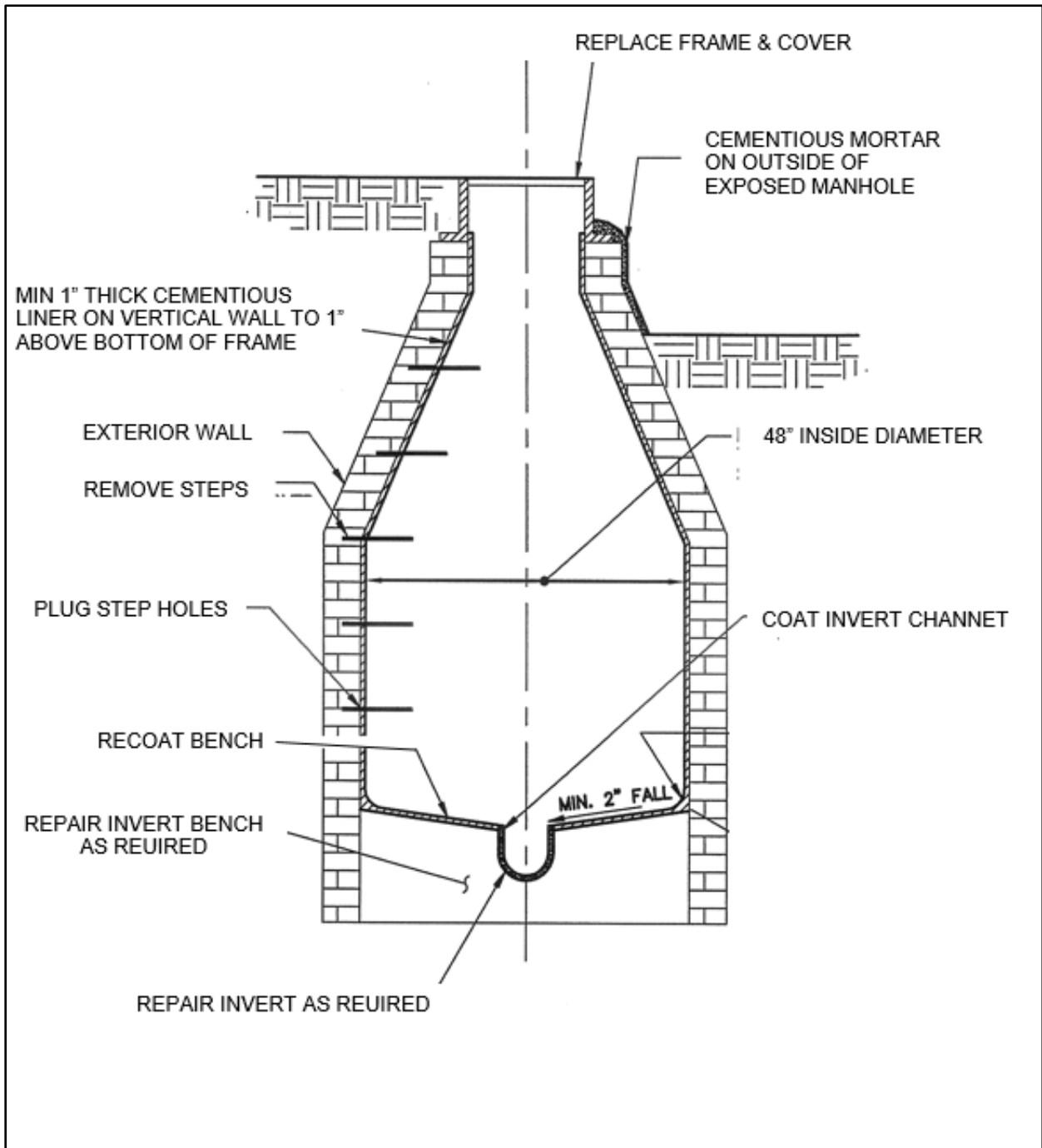

	CITY OF NORTH AUGUSTA, SOUTH CAROLINA		
	MANHOLE REHABILITAITON 2024-07-4290		
	NTS Scale	BY James Suttron	DETAIL NO. 1

## MANHOLE FRAME & COVER DETAIL DRAWING - 2

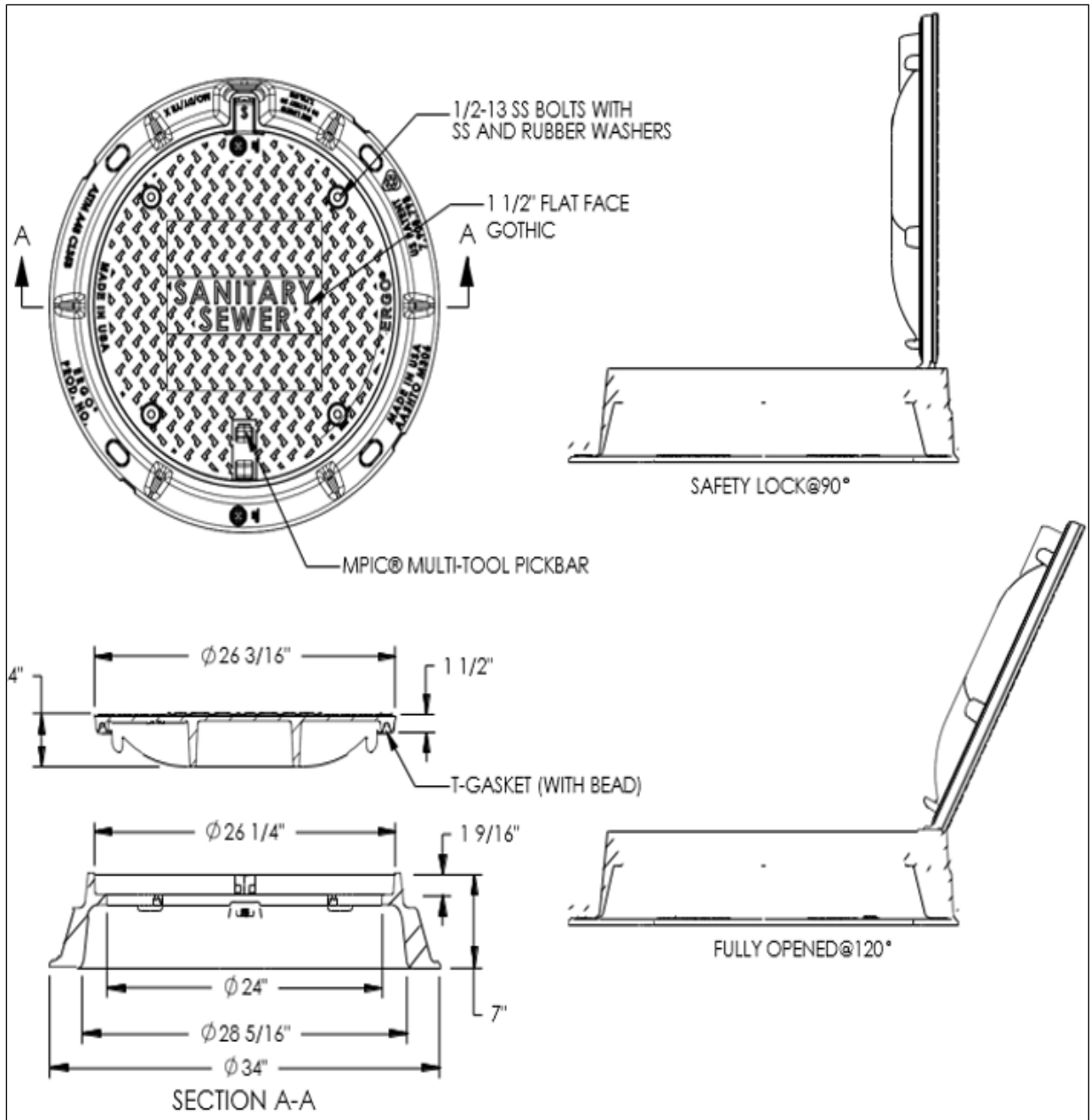

## BY-PASS PUMPING

### SCOPE OF WORK

The Contractor shall provide all necessary pumping equipment, piping and appurtenances for diverting flow around pipe segments as required but not limited to; manhole relining, CCIP relining and CCTV pipe inspections.

#### 3.01 Bypass Pumping Minimum Requirements

- A. The Contractor shall have full time, onsite qualified pump personnel for monitoring the entire bypass installation while it is in operation. The entire length of bypass piping shall be walked periodically and inspected to monitor for leaks.
- B. Bypass pumps must be fully automatic self-priming units that do not require the use of foot-valves or vacuum pumps to prime the system. No electric pumps will be allowed; all pumps must be diesel powered.
- C. All materials, equipment, etc., must be in good condition, and shall all not have visible damage such as cracks, holes, foreign material, blisters, etc.
- D. The Contractor shall provide all necessary equipment, plugs, hoses, gauges and necessary appurtenances to install flow control plug(s), maintain the plug during use and remove the plug at completion. Plugs must be selected and installed according to the size of the pipe to be plugged. Plugs shall be secured and anchored to prevent plug movement or escape into the adjoining pipe system should the plug fail. An additional plug must be onsite and ready to be installed in the event a plug fails or becomes dislodged.
- E. The Contractor shall provide suitable spill control and containment measures to avoid environmental contamination by pumps, fuels, or lubricants.
- F. The Contractor shall have adequate standby equipment available and ready for immediate operation and use in the event of an emergency or breakdown. Standby pump(s), of equal or greater capacity than the largest pump utilized, shall be installed at the mainline flow bypassing locations, ready for use in the event of primary pump failure.
- G. Bypass pumping system shall be capable of bypassing the flow around the work area and of releasing any amount of flow up to full available flow into the work area as necessary for satisfactory performances of work.
- H. The Contractor shall maintain sewer flow around the work area in a manner that will not cause surcharging of sewers, or damage to sewer, and that will protect public and private property from damage and flooding.
- I. The pump system shall be designed to pump a flow capacity of 425 gallons per minute.

# STANDARD GENERAL CONDITIONS OF THE CONSTRUCTION CONTRACT

## ARTICLE 22 – PRELIMINARY MATTERS

### 22.01 Delivery of Bonds and Insurance

- A. Bonds: When Contractor delivers the executed counterparts of the Agreement to Owner, Contractor shall also deliver Owner such bonds as Contractor may be required to furnish.
- B. Contractor's Insurance: When Contractor delivers the executed counterparts of the Agreement to Owner, Contractor shall also deliver to Owner, with copies to each named insured and additional insured, the certificates and other evidence of insurance required to be provided by Contractor in accordance with Article #26 .

### 22.02 Copies of Documents

- A. Owner shall furnish to Contractor four printed copies of the Contract (including one fully executed counterpart of the Agreement), and one copy in electronic portable document format (PDF).

### 22.03 Before Starting Construction

- A. Preliminary Schedules: Within 10 days after the Effective Date of the Contract, Contractor shall submit to Owner for timely review:
  - 1. A preliminary Progress Schedule indicating the times (numbers of days or dates) for starting and completing the various stages of the Work, including any Milestones specified in the Contract;
  - 2. a preliminary Schedule of Submittals; and
  - 3. a preliminary Schedule of Values for all of the Work which includes quantities and prices of items which when added together equal the Contract Price and subdivides the Work into component parts in sufficient detail to serve as the basis for progress payments during performance of the Work. Such prices will include an appropriate amount of overhead and profit applicable to each item of Work.

### 22.04 Preconstruction Conference:

- A. Before any Work at the Site is started, a conference attended by Owner, Contractor, and others as appropriate will be held to establish a working understanding among the parties as to the Work and to discuss the schedules, submittals, processing Applications for Payment, electronic or digital transmittals, and maintaining required records.
- B. At this conference Owner and Contractor each shall designate, in writing, a specific individual to act as its authorized representative with respect to the services and responsibilities under the Contract. Such individuals shall have the authority to



transmit and receive information, render decisions relative to the Contract, and otherwise act on behalf of each respective party.

#### 22.05 Electronic Transmittals

- A. Except as otherwise stated elsewhere in the Contract, the Owner and Contractor may transmit, and shall accept, Project-related correspondence, text, data, documents, drawings and other submittals, in electronic media or digital format, either directly, or through access to a secure Project website.
- B. When transmitting items in electronic media or digital format, the transmitting party makes no representations as to long term compatibility, usability, or readability of the items resulting from the recipient's use of software application packages, operating systems, or computer hardware differing from those used in the drafting or transmittal of the items, or from those established in applicable transmittal protocols.

### **ARTICLE 23 - DOCUMENTS INTENT AND REQUIREMENTS**

#### 23.01 Intent

- A. The Contract Documents are complementary; what is required by one is as binding as if required by all.
- B. The Contract supersedes prior negotiations, representations, and agreements, whether written or oral.
- C. Owner will issue clarifications and interpretations of the Contract Documents as provided herein.

#### 23.02 Standards, Specifications, Codes, Laws and Regulations

- A. Reference in the Contract Documents to standard specifications, reference standards, or codes of any technical society, organization, or association, or to Laws or Regulations, whether such reference be specific or by implication, shall mean the standard specification, reference standard, code, or Laws or Regulations in effect at the time of opening of Bids.

#### 23.03 Reporting and Resolving Discrepancies

##### A. Reporting Discrepancies

1. Contractor's Verification of Figures and Field Measurements: Before undertaking each part of the Work, Contractor shall carefully study the Contract Documents, and check and verify pertinent figures and dimensions therein, particularly with respect to field measurements. Contractor shall promptly report in writing to Owner any conflict, error, ambiguity, or discrepancy that Contractor discovers, or has actual knowledge of, and shall not proceed with any Work affected thereby until the conflict, error, ambiguity, or discrepancy is resolved by a clarification or interpretation by Owner, or by an amendment or supplement to the Contract Documents.

2. Contractor's Review of Contract Documents: If, before or during the performance of the Work, Contractor discovers any conflict, error, ambiguity, or discrepancy within the Contract Documents, or between the Contract Documents and (a) any applicable Law or Regulation, (b) actual field conditions, (c) any standard specification, reference standard, or code, then Contractor shall promptly report it to Owner in writing. Contractor shall not proceed with the Work affected thereby as required until the conflict, error, ambiguity, or discrepancy is resolved, by a clarification or interpretation by Owner, or by an amendment or supplement to the Contract Documents.

B. Resolving Discrepancies

1. Except as may be otherwise specifically stated in the Contract Documents, the provisions of the part of the Contract Documents prepared by Owner shall take precedence in resolving any conflict, error, ambiguity, or discrepancy between such provisions of the Contract Documents and:
  - a) The provisions of any standard specification, reference standard, or code, or the instruction of any Supplier; or
  - b) the provisions of any Laws or Regulations applicable to the performance of the Work (unless such an interpretation of the provisions of the Contract Documents would result in violation of such Law or Regulation).

23.04 Requirements of the Contract Documents

- A. During the performance of the Work and until final payment, Contractor shall submit to the Owner all matters in question concerning the requirements of the Contract Documents, or relating to the acceptability of the Work under the Contract Documents, as soon as possible after such matters arise.
- B. Owner will, with reasonable promptness render a written clarification, interpretation, or decision on the issue submitted, or initiate an amendment or supplement to the Contract Documents. Owners written clarification, interpretation, or decision will be final and binding on Contractor

## ARTICLE 24 - COMMENCEMENT AND PROGRESS OF WORK

### 24.01 Commencement of Contract Times; Notice to Proceed

- C. Contractor has **TBD** calendar days from the date of the Notice to Proceed (NTP) to complete the project. It is hereby understood and mutually agreed, by and between the Contractor and the Owner, that the date of beginning, rate of progress and the time for completion of the work to be done hereunder are essential conditions of this contract. The Contractor agrees that said work shall be prosecuted regularly, diligently, and uninterrupted at such rate of progress as will ensure full completion thereof within the time specified. It is expressly understood and agreed, by and between the Contractor and the Owner, that the time for the completion of the work described herein is a reasonable time for the completion of the same.

### 24.02 Start of Work

- A. Contractor shall start to perform the Work on the date when the Contract Times commence to run.

### 24.03 Progress Schedule

- A. Contractor shall adhere to the Progress Schedule established in accordance with Article 23 as it may be adjusted from time to time as provided below.
  - 1. Contractor shall submit to Owner for acceptance proposed adjustments in the Progress Schedule that will not result in changing the Contract Times.
  - 2. Proposed adjustments in the Progress Schedule that will change the Contract Times shall require a Change Order.
- B. Contractor shall carry on the Work and adhere to the Progress Schedule during all disputes or disagreements with Owner. No Work shall be delayed or postponed pending resolution of any disputes or disagreements, or during any appeal process or as Owner and Contractor may otherwise agree in writing.

### 24.04 Delays in Contractor's Progress

- A. Contractor shall not be entitled to an adjustment in Contract Price or Contract Times for delay, disruption, or interference caused by or within the control of Contractor. Delay, disruption, and interference attributable to and within the control of a Subcontractor or Supplier shall be deemed to be within the control of Contractor.
- B. If Contractor's performance or progress is delayed, disrupted, or interfered with by unanticipated causes not the fault of and beyond the control of Owner, Contractor, and those for which they are responsible, then Contractor shall be entitled to an equitable adjustment in Contract Times. Contractor's entitlement to an adjustment of the Contract Times is conditioned on such adjustment being essential to Contractor's ability to complete the Work within the Contract Times. Such an adjustment shall be Contractor's sole and exclusive remedy for the delays, disruption, and interference described in this paragraph. Causes of delay, disruption, or interference that may give rise to an adjustment in Contract Times under this

paragraph include but are not limited to the following:

1. Severe and unavoidable natural catastrophes such as fires, floods, epidemics, and earthquakes;
  2. abnormal weather conditions; and
  3. acts of war or terrorism.
- C. Contractor shall not be entitled to an adjustment in Contract Price or Contract Times for any delay, disruption, or interference if such delay is concurrent with a delay, disruption, or interference caused by or within the control of Contractor.
- D. Contractor must submit any Change Proposal seeking an adjustment in Contract Times under this paragraph within 30 days of the commencement of the delaying, disrupting, or interfering event.

## **ARTICLE 25 – AVAILABILITY OF LANDS**

### **25.01 Availability of Lands**

- A. Owner shall provide all easements and right of ways and notify Contractor of any encumbrances or restrictions related to use of the Site with which Contractor must comply in performing the Work.

### **25.02 Limitation on Use of Site and Other Areas:**

- A. Contractor shall confine construction equipment, temporary construction facilities, the storage of materials and equipment, and the operations of workers to the Site, adjacent areas that Contractor has arranged to use through construction easements or otherwise, and other adjacent areas permitted by Laws and Regulations, and shall not unreasonably encumber the Site and such other adjacent areas with construction equipment or other materials or equipment. Contractor shall assume full responsibility for (a) damage to the Site; (b) damage to any such other adjacent areas used for Contractor's operations; (c) damage to any other adjacent land or areas; and (d) for injuries and losses sustained by the owners or occupants of any such land or areas; provided that such damage or injuries result from the performance of the Work or from other actions or conduct of the Contractor or those for which Contractor is responsible.
- B. The Contractor has no authority to permit the use of any portion of the premises by anyone except for business connected with the Work.
- C. If a damage or injury claim is made by the owner or occupant of any such land or area because of the performance of the Work, or because of other actions or conduct of the Contractor or those for which Contractor is responsible, Contractor shall (a) take immediate corrective or remedial action as required or otherwise; (b) promptly attempt to settle the claim as to all parties through negotiations with such owner or occupant, or otherwise resolve the claim by arbitration or dispute resolution.
- D. During the progress of the Work the Contractor shall keep the Site and other adjacent areas free from accumulations of waste materials, rubbish, and other debris.

Removal and disposal of such waste materials, rubbish, and other debris shall conform to applicable Laws and Regulations.

- E. Prior to Substantial Completion of the Work Contractor shall clean the Site and the Work and make it ready for utilization by Owner. At the completion of the Work Contractor shall remove from the Site and adjacent areas all tools, construction equipment and machinery, and surplus materials and shall restore to original condition all property not designated for alteration by the Contract Documents.

## **ARTICLE 26 – BONDS AND INSURANCE**

### **26.01 Performance, Payment, and Other Bonds**

- A. Contractor shall furnish a performance bond and a payment bond, each in an amount at least 100% equal to the Contract Price, as security for the faithful performance and payment of all of Contractor's obligations under the Contract. These bonds shall remain in effect until one year after the date when final payment becomes due or until completion of the correction period.
- B. Contractor shall obtain the required bonds from surety companies that are duly licensed or authorized in the State of South Carolina in which the Project is located to issue bonds in the required amounts.
- C. If the surety on a bond furnished by Contractor is declared bankrupt or becomes insolvent, or its right to do business is terminated in the State of South Carolina or jurisdiction where any part of the Project is located, or the surety ceases to meet the requirements above, then Contractor shall promptly notify Owner within 20 days after the event giving rise to such notification, provide another bond and surety, both of which shall comply with the bond and surety requirements above.
- D. If Contractor has failed to obtain a required bond, Owner may exclude the Contractor from the Site and exercise Owner's termination rights.

### **26.02 Insurance—General Provisions**

- A. Contractor shall deliver to Owner, with copies to each named insured and additional, certificates of insurance establishing that Contractor has obtained and is maintaining the policies and coverages required by the Contract.
- B. If Contractor fails to maintain required insurance, Owner may exclude the Contractor from the Site, and exercise Owner's termination rights.
- C. Owner does not represent that insurance coverage and limits established in this Contract necessarily will be adequate to protect Contractor or Contractor's interests.
- D. The insurance and insurance limits required herein shall not be deemed as a limitation on Contractor's liability under the indemnities granted to Owner and other individuals and entities in the Contract.

### 26.03 Contractor's Insurance

- A. Contractor shall purchase and maintain insurance for:
1. Worker's Compensation: Insurance to cover obligations imposed by federal and state statutes having jurisdiction of Contractor's employees engaged in the performance of the work; and, Employer's Liability insurance of not less than \$1,000,000 for each accident, \$1,000,000 disease for each employee, and \$1,000,000 disease policy limits.
  2. Commercial Business Automobile: Liability insurance with a combined single limit for bodily injury and property damage of not less than \$1,000,000 each occurrence with respect to the Contractor's any owned, hired, and non-owned vehicles assigned to or used in performance of the Contractor's work.
  3. Commercial General: Liability Insurance: with a limit of not less than \$1,000,000 for each occurrence with a \$1,000,000 Products and Completed Operations Aggregate and \$1,000,000 General Aggregate Limit. The policy shall include coverage for bodily injury, broad form property damage, personal injury, products/completed operations and blanket contractual coverage.

## **ARTICLE 27 – CONTRACTOR'S RESPONSIBILITY**

### 27.01 Supervision and Superintendence

- A. Contractor shall supervise, inspect, and direct the Work competently and efficiently, devoting such attention thereto and applying such skills and expertise as may be necessary to perform the Work in accordance with the Contract Documents. Contractor shall be solely responsible for the means, methods, techniques, sequences, and procedures of construction.
- B. It is understood that the specifications and other contract documents do not purport to control the method of performing the work. The Contractor shall assume the entire responsibility for the method of performing and installing the work. Suggestions as to the method included in the contract documents shall be deemed advisory only and the feasibility of such methods or the lack thereof shall not affect the Contractor's liability or status to complete the work under this contract.
- C. Contractor shall provide competent, suitably qualified personnel to survey and lay out the Work and perform construction as required by the Contract Documents. Contractor shall at all times maintain good discipline and order at the Site.

### 27.02 Working Hours

- A. Work at the Site shall be performed Monday through Friday during the hours of 7:00 a.m. to 7:00 p.m. Contractor will not perform Work on a Saturday, Sunday, or any legal holiday. Contractor may perform Work outside regular working hours only with Owner's written consent, which will not be unreasonably withheld.

### 27.03 Services, Materials, and Equipment

- A. Unless otherwise specified in the Contract Documents, Contractor shall provide and assume full responsibility for all services, materials, equipment, labor, transportation, construction equipment and machinery, tools, fuel, power, light, water, sanitary facilities, temporary facilities, and all other facilities and incidentals necessary for the performance and completion of the Work, whether or not such items are specifically called for in the Contract Documents.
- B. The Contractor must make all necessary application and arrangements and pay all fees and charges for temporary water necessary for the proper completion of the project up to the time of final acceptance. The Contractor is responsible for payment of any temporary piping and connections.
- C. All materials incorporated into the Work shall be of good quality and new. Contractor shall furnish satisfactory evidence (including reports of required tests) as to the source, kind, and quality of materials.
- D. All materials shall be stored, protected, clean and conditioned in accordance with instructions of the applicable Supplier.

### 27.04 Substitute or Equal Items

- A. Whenever an item of material is specified or described in the Contract Documents by using the name of a proprietary item or the name of a particular Supplier, the Contract Price has been based upon Contractor furnishing such item as specified. The specification or description of such an item is intended to establish the type, function, appearance, and quality required. Unless the specification or description contains or is followed by words reading that no like, equivalent, or "or equal" item is permitted, Contractor may request that Owner authorize the use of other items of material or items from other proposed suppliers under the circumstances described below.
  - 1. If Owner in its sole discretion determines that an item of material or equipment proposed by Contractor is functionally equal to that named and sufficiently similar so that no change in related Work will be required, Owner shall deem it an "or equal" item. For the purposes of this paragraph, a proposed item of material will be considered functionally equal to an item so named if, in the exercise of reasonable judgement Owner determines that:
    - a) It is at least equal in materials of construction, quality, durability, appearance, strength, and design characteristics;
    - b) it will reliably perform at least equally well the function and achieve the results imposed by the design concept of the completed Project as a functioning whole;
    - c) it has a proven record of performance and availability of responsive service.
  - a) Contractor certifies that, if approved and incorporated into the Work:
    - 1. There will be no increase in cost to the Owner or increase in Contract Times; and
    - 2. it will conform substantially to the detailed requirements of the item named in the

Contract Documents.

27.05 Subcontractors, Suppliers, and Others

- A. Contractor may retain Subcontractors and Suppliers for the performance of parts of the Work. Such Subcontractors and Suppliers must be acceptable to Owner.
- B. On a monthly basis Contractor shall submit to Owner a complete list of all Subcontractors and Suppliers having a direct contract with Contractor, and of all other Subcontractors and Suppliers known to Contractor at the time of submittal.
- C. Contractor shall be fully responsible to Owner for all acts and omissions of the Subcontractors, Suppliers, and other individuals or entities performing or furnishing any of the Work.
- D. Contractor shall be solely responsible for scheduling and coordinating the work of Subcontractors, Suppliers, and all other individuals or entities performing or furnishing any of the Work.
- E. All Work performed for Contractor by a Subcontractor or Supplier shall be pursuant to an appropriate contractual agreement that specifically binds the Subcontractor or Supplier to the applicable terms and conditions of the Contract Documents for the benefit of Owner.

27.06 Permits

The Contractor shall be required to obtain a City of North Augusta business license and pay all fees necessary to perform the work.

27.07 Taxes

Contractor shall pay all sales, consumer, use, and other similar taxes required to be paid by Contractor in accordance with the Laws and Regulations of the place of the Project which are applicable during the performance of the Work.

27.08 Laws and Regulations

- A. Contractor shall give all notices required by and shall comply with all Laws and Regulations applicable to the performance of the Work. Except where otherwise expressly required by applicable Laws and Regulations. Owner shall be responsible for monitoring Contractor's compliance with any Laws or Regulations.
- B. If Contractor performs any Work or takes any other action knowing or having reason to know that it is contrary to Laws or Regulations, Contractor shall bear all resulting costs and losses.

27.09 Record Documents

- A. Contractor shall maintain in a safe place at the Site one printed record copy of all Drawings, Specifications, Addenda, Change Orders, Work Change Directives, Field Orders, written interpretations and clarifications. Contractor shall keep such record documents in good order and annotate them to show changes made during construction.



#### 27.10 Safety and Protection

- A. Contractor shall comply with all applicable Laws and Regulations relating to the safety of persons or property, or to the protection of persons or property from damage, injury, or loss; and shall erect and maintain all necessary safeguards for such safety and protection.
1. The Contractor shall perform all of the Work in accordance with applicable OSHA standards. Emphasis shall be placed upon the requirements for entering confined spaces and with the equipment being utilized for pipe renewal.
  2. The contractor shall clean public walkways adjoining the construction site of accumulated trash and debris.
  3. The contractor's construction operations shall not occupy public walkways except where pedestrian protection is provided.
  4. The Contractor shall remove barriers and enclosures upon completion of the work.
  5. The Contractor shall conform to all work safety requirements of pertinent regulatory agencies, and shall secure the site for the working conditions in compliance with the same.
- B. Contractor shall inform Owner of the specific requirements of Contractor's safety program with which Owner's representatives must comply while at the Site.

#### 27.11 Traffic and Pedestrian Control

- A. The Contractor shall provide traffic control signs, signals, flashing lights, guards, plates, enclosures, barricades and notices, including all special design signs as may be required by the City of North Augusta and/or the South Carolina Department of Transportation.
1. The Contractor shall maintain local traffic at all times during all phases of this project in a manner causing the least amount of inconvenience to the abutting property owners
  2. The Contractor shall hold harmless the Owner and all its representation from all suits, actions, of claims of any character brought on account of any injuries or damages sustained by any person Or persons in the performance the Work.
  3. The Contractor must maintain one-lane, two-way traffic at all times and maintain customer access to local businesses at all times throughout the course of the work.
  4. The Contractor must provide and maintain adequate barricades, construction signs, torches, flashers, guards, and flagmen as required in pedestrian and vehicular traffic areas. Regulations of local authorities must be complied with.
  5. The Contractor must provide suitable crossings at street intersections and driveways and supply such aid as may be required for pedestrians and motorists, including delivery vehicles, to safely negotiate the construction areas.
  6. The contractor shall require that no construction materials be stored or placed on

the path of motor vehicle or pedestrian travel without proper signage and safety barriers.

7. The contractor shall clean public walkways adjoining the construction site of accumulated trash and debris.

8. The Contractor shall remove barriers and enclosures upon completion of the work.

#### 27.12 Emergencies

A. In emergencies affecting the safety or protection of persons or the Work or property at the Site or adjacent thereto, Contractor is obligated to act to prevent threatened damage, injury, or loss. Contractor shall give Owner prompt written notice if Contractor believes that any significant changes in the Work or variations from the Contract Documents have been caused thereby or are required as a result thereof. If Owner determines that a change in the Contract Documents is required because of the action taken by Contractor in response to such an emergency, a Work Change Order will be issued.

#### 27.13 Samples, and Submittals

A. Contractor shall submit the number of Samples and supporting documents as required in the attached Specifications.

B. Contractor shall clearly identify each Sample as to material, pertinent data for which intended and other data as Owner may require.

#### 27.14 Contractor's Warranty and Guarantee

A. Contractor warrants and guarantees to Owner that all Work will be in accordance with the Contract Documents and will not be defective. Owner and its officers, directors, members, partners, employees, agents, consultants, and subcontractors shall be entitled to rely on Contractor's three (3) year warranty and guarantee.

### **ARTICLE 28 – OWNER'S RESPONSIBILITY**

#### 28.01 Furnish Data

A. Owner shall promptly furnish the data required of Owner under the Contract Documents.

#### 28.02 Pay When Due

A. Owner shall make payments to Contractor when they are due as provided in the Agreement.

#### 28.03 Lands and Easements

A. Owner's duties with respect to providing lands and easements are set forth in Article 27.

#### 28.04 Permits

- A. Owner shall provide South Carolina Department of Transportation Work within Right-Of-Way Encroachment permit.

#### 28.04 Change Orders

- A. Owner's responsibilities with respect to Change Orders are set forth in Article 32.

#### 28.05 Safety Programs

- A. While at the Site, Owner's employees and representatives shall comply with the specific applicable requirements of Contractor's safety programs of which Owner has been informed.

### **ARTICLE 29 - OWNERS' STAUS DURING CONSTRUCTIONOWNER'S**

#### 29.01 Owner's Representative

##### Visits to Site:

- A. Owner's representative will make visits to the Site at intervals appropriate to the various stages of construction as deemed necessary in order to the progress that has been made and the quality of the various aspects of Contractor's executed Work. Based on information obtained during such visits and observations, Owner's representative, for the benefit of Owner, will determine, in general, if the Work is proceeding in accordance with the Contract Documents. Owner's representative efforts will be directed toward providing for Owner a greater degree of confidence that the completed Work will conform generally to the Contract Documents. On the basis of such visits and observations.

#### 29.03 Rejecting Defective Work

- A. Owner's representative has the authority to reject Work in accordance with Article 35.

#### 29.04 Change Orders and Payments

- A. Owner's representative authority as to Change Orders is set forth in Article 32.
- B. Owner's authority as to Applications for Payment is set forth in Article 36.

#### 29.05 Determinations for Unit Price Work

- A. Owner's representative will determine the actual quantities and classifications of Unit Price Work performed by Contractor as set forth in Article 34.

#### 29.06 Decisions on Requirements of Contract Documents and Acceptability of Work

- A. Owner's representative will render decisions regarding the requirements of the Contract Documents, and judge the acceptability of the Work, pursuant to the specific procedures set forth herein for initial interpretations, Change Proposals, and acceptance of the Work. In rendering such decisions and judgments.

## 29.07 Limitations on Owner's Representative Authority and Responsibilities

- A. Owner will not supervise, direct, control, or have authority over or be responsible for Contractor's means, methods, techniques, sequences, or procedures of construction, or the safety precautions and programs incident thereto, or for any failure of Contractor to comply with Laws and Regulations applicable to the performance of the Work. Owner will not be responsible for Contractor's failure to perform the Work in accordance with the Contract Documents.
- B. Owner will not be responsible for the acts or omissions of Contractor or of any Subcontractor, any Supplier, or of any other individual or entity performing any of the Work.
- C. Owner's review of the final Application for Payment and accompanying documentation and all maintenance and operating instructions, schedules, guarantees, bonds, certificates, tests and approvals, and other documentation required to be delivered by Article 36 will only be to determine generally that their content complies with the requirements of, and in the case of certificates of inspections, tests, and approvals, that the results certified indicate compliance with the Contract Documents.

## **ARTICLE 30 – AMENDING THE CONTRACT**

### 30.01 Amending and Supplementing Contract Documents

- A. The Contract Documents may be amended or supplemented by a Change Order.
  - 1. Change Orders:
    - a) If an amendment or supplement to the Contract Documents includes a change in the Contract Price or the Contract Times, such amendment or supplement must be set forth in a Change Order. A Change Order also may be used to establish amendments and supplements of the Contract Documents that do not affect the Contract Price or Contract Times.
    - b) Owner and Contractor may amend those terms and conditions of the Contract Documents that do not involve (1) the performance or acceptability of the Work, (2) the Specifications, or Scope of Work. Such an amendment shall be set forth in a Change Order.

### 30.02 Unauthorized Changes in the Work

- B. Contractor shall not be entitled to an increase in the Contract Price or an extension of the Contract Times with respect to any work performed that is not required by the Contract Documents, as amended, modified, or supplemented.

### 30.03 Change of Contract Price

- C. The Contract Price may only be changed by a Change Order. Any Change Proposal for an adjustment in the Contract Price shall comply with the provisions of this Article. Any Claim for an adjustment of Contract Price shall comply with the provisions of Article 33.

- D. An adjustment in the Contract Price will be determined as follows:
1. Where the Work involved is covered by unit prices contained in the Contract Documents, then by application of such unit prices to the quantities of the items involved (subject to the provisions of Article 34); or
  2. where the Work involved is not covered by unit prices contained in the Contract Documents and the parties do not reach mutual agreement to a lump sum, then on the basis of the Cost of the Work (determined as provided in Article 34) plus a Contractor's fee for overhead and profit.

#### 30.04 Change of Contract Times

- A. The Contract Times may only be changed by a Change Order. Any Change Proposal for an adjustment in the Contract Times shall comply with the provisions of Article 32. Any Claim for an adjustment in the Contract Times shall comply with the provisions of Article 33.
- B. An adjustment of the Contract Times shall be subject to the limitations set forth in Paragraph 4.03, concerning delays in Contractor's progress.

#### 30.05 Change Proposals

- A. Contractor shall submit a Change Proposal to Owner to request an adjustment in the Contract Times or Contract Price by:
1. Submit each Change Proposal to Owner promptly (but in no event later than 30 days) after the start of the event giving rise thereto, or after such initial decision. The Contractor shall submit supporting data, including the proposed change in Contract Price or Contract Time (if any), to the Owner within 15 days after the submittal of the Change Proposal. The supporting data shall be accompanied by a written statement that the supporting data are accurate and complete, and that any requested time or price adjustment is the entire adjustment to which Contractor believes it is entitled as a result of said event.
  2. Owner will review each Change Proposal and, either deny the Change Proposal in whole, approve it in whole, or deny it in part and approve it in part. Such actions shall be in writing, with a copy provided to Contractor.
  3. Owner's decision will be final and binding upon Contractor, unless Contractor appeals the decision by filing a Claim under Article 33.

#### 30.06 Execution of Change Orders

- A. Owner and Contractor shall execute appropriate Change Orders covering:
1. Changes in the Contract Price or Contract Times which are agreed to by the parties, including any undisputed sum or amount of time for Work actually performed in accordance with a Work Change Directive; and
  2. changes in Contract Price resulting from an Owner set-off, unless Contractor has duly contested such set-off;

- B. If Owner or Contractor refuses to execute a Change Order that is required to be executed under the terms of this Paragraph, it shall be deemed to be of full force and effect, as if fully executed.

## **ARTICLE 31 – CLAIMS**

### **31.01 Claims Process:**

- A. The following disputes between Owner and Contractor shall be submitted to the Claims process set forth in this Article.

1. The party submitting a Claim shall deliver it directly to the other party to the Contract promptly (but in no event later than 30 days) after the start of the event giving rise thereto; The responsibility to substantiate a Claim shall rest with the party making the Claim. In the case of a Claim by Contractor seeking an increase in the Contract Times or Contract Price, or both, Contractor shall certify that the Claim is made in good faith, that the supporting data are accurate and complete, and that to the best of Contractor’s knowledge and belief the amount of time or money requested accurately reflects the full amount to which Contractor is entitled.
2. The party receiving a Claim shall review it thoroughly, giving full consideration to its merits. The two parties shall seek to resolve the Claim through the exchange of information and direct negotiations. The parties may extend the time for resolving the Claim by mutual agreement. All actions taken on a Claim shall be stated in writing and submitted to the other party.

- B. Mediation:

3. At any time after initiation of a Claim, Owner and Contractor may mutually agree to mediation of the underlying dispute. The agreement to mediate shall stay the Claim submittal and response process.
4. If Owner and Contractor agree to mediation, then after 60 days from such agreement, either Owner or Contractor may unilaterally terminate the mediation process, and the Claim submittal and decision process shall resume as of the date of the termination. If the mediation proceeds but is unsuccessful in resolving the dispute, the Claim submittal and decision process shall resume as of the date of the conclusion of the mediation, as determined by the mediator.
5. Owner and Contractor shall each pay one-half of the mediator’s fees and costs.

- C. Partial Approval: If the party receiving a Claim approves the Claim in part and denies it in part, such action shall be final and binding unless within 30 days of such action the other party invokes the procedure set forth in Article 38 for final resolution of disputes.

- D. Denial of Claim: If efforts to resolve a Claim are not successful, the party receiving the Claim may deny it by giving written notice of denial to the other party. If the receiving party does not take action on the Claim within 90 days, then either Owner or Contractor may at any time thereafter submit a letter to the other party indicating

that as a result of the inaction, the Claim is deemed denied, thereby commencing the time for appeal of the denial. A denial of the Claim shall be final and binding.

- E. Final and Binding Results: If the parties reach a mutual agreement regarding a Claim, whether through approval of the Claim, direct negotiations, mediation, or otherwise; or if a Claim is approved in part and denied in part, or denied in full, and such actions become final and binding; then the results of the agreement or action on the Claim shall be incorporated in a Change Order to the extent they affect the Contract, including the Work, the Contract Times, or the Contract Price.

## **ARTICLE 32 - COST OF WORK**

### **32.01 Cost of the Work**

- A. Purposes for Determination of Cost of the Work: The term Cost of the Work means the sum of all costs necessary for the proper performance of the Work at issue, as further defined below.
  - 1. To determine the value of a Change Order, Change Proposal, Claim, set-off, or other adjustment in Contract Price. When the value of any such adjustment is determined on the basis of Cost of the Work, Contractor is entitled only to those additional or incremental costs required because of the change in the Work or because of the event giving rise to the adjustment.

### **32.02 Unit Price Work**

- A. Where the Contract Documents provide that all or part of the Work is to be Unit Price Work, initially the Contract Price will be deemed to include for all Unit Price Work an amount equal to the sum of the unit price for each separately identified item of Unit Price Work times the estimated quantity of each item as indicated in the Agreement.
- B. The estimated quantities of items of Unit Price Work are not guaranteed and are solely for the purpose of comparison of Bids and determining an initial Contract Price. Payments to Contractor for Unit Price Work will be based on actual quantities.
- C. Each unit price will be deemed to include an amount considered by Contractor to be adequate to cover Contractor's overhead and profit for each separately identified item.

## **ARTICLE 33 – INSPECTIONS, TEST AND DEFECTS**

### **33.01 Access to Work**

- A. Owner and personnel of Owner, independent testing laboratories, and authorities having jurisdiction will have access to the Site and the Work at reasonable times for their observation, inspection, and testing. Contractor shall provide them proper and safe conditions for such access and advise them of Contractor's safety procedures and programs so that they may comply therewith as applicable.

### **33.02 Tests, Inspections, and Approvals**

- A. Contractor shall give Owner timely notice of readiness of the Work for all required

inspections and tests, and shall cooperate with inspection and testing personnel to facilitate required inspections and tests.

- B. Such inspections and tests shall be performed by independent testing laboratories, or other qualified individuals or entities acceptable to Owner.
- C. If the Contract Documents require the Work (or part thereof) to be approved by Owner, then Contractor shall assume full responsibility for arranging and obtaining such approvals.

### 33.03 Defective Work

- A. Contractor's Obligation: It is Contractor's obligation to assure that the Work is not defective.
- B. Notice of Defects: Prompt notice of all defective Work of which Owner has actual knowledge will be given to Contractor.
- C. Correction, or Removal and Replacement: Promptly after receipt of written notice of defective Work, Contractor shall correct all such defective Work, whether or not installed, or completed, or, if Owner has rejected the defective Work, remove it from the Project and replace it with Work that is not defective.
- D. Costs and Damages: In addition to its correction, removal, and replacement obligations with respect to defective Work, Contractor shall pay all claims, costs, losses, and damages arising out of or relating to defective Work, including but not limited to the cost of the testing, correction, removal, replacement, or reconstruction of such defective Work,

### 33.04 Owner May Stop the Work

- A. If the Work is defective, or Contractor fails to supply sufficient skilled workers or suitable materials, or fails to perform the Work in such a way that the completed Work will conform to the Contract Documents, then Owner may order Contractor to stop the Work, or any portion thereof, until the cause for such order has been eliminated; however, this right of Owner to stop the Work shall not give rise to any duty on the part of Owner to exercise this right for the benefit of Contractor, any Subcontractor, any Supplier, any other individual or entity, or any surety for, or employee or agent of any of them.

## **ARTICLE 34 – PAYMENTS TO CONTRACTOR**

### 34.01 Progress Payments

- A. The Schedule of Values established as provided in Article 23 will serve as the basis for progress payments and will be incorporated into a form of Application for Payment. Progress payments on account of Unit Price Work will be based on the number of units completed during the pay period. Progress payments for cost-based Work will be based on Cost of the Work completed by Contractor during the pay period.



34.02 Retainage:

- A. Unless otherwise specified within the Contract Documents, the Owner will make progress payments to the Contractor, in installments based upon an estimated percentage of work completion. With each installment, the Contractor shall be paid at least ninety percent (90%) of the total amount earned, as determined and approved by the Owner, withholding the balance as retainage, to assure faithful performance of the Contract.

34.03 Applications for Payments:

- A. At least 20 days before the date established in the Agreement for each progress payment but not more often than once a month, Contractor shall submit to Owner for review an Application for Payment filled out and signed by Contractor for the Work inspected and completed as of the date of the Application. The application for payment shall include but not limited to; Contractors detailed Invoice, Project Name, Project Number, Purchase Order Number, Invoice Number, Item Quantity, Unit Item List Price, Tax and Total Amount Due.
- B. Beginning with the second Application for Payment, each Application shall include an affidavit of Contractor stating that all previous progress payments received on account of the Work have been applied on account to discharge Contractor's legitimate obligations associated with prior Applications for Payment.

34.04 Review of Applications:

- A. Owner's representative will, within 2 days after receipt of each Application for Payment, including each resubmittal, either indicate in writing a recommendation of payment and present the Application to Owner or return the Application to Contractor indicating in writing reasons for refusing to recommend payment. In the latter case, Contractor may make the necessary corrections and resubmit the Application.
- B. Owner's representatives recommendation of any payment requested in an Application for Payment will constitute a representation to Owner, based on observations of the executed Work and information that:
  - a) The Work has progressed to the point indicated;
  - b) the quality of the Work is generally in accordance with the Contract Documents;
  - c) the conditions precedent to Contractor's being entitled to such payment appear to have been fulfilled.
- C. Owner's representative will recommend reductions in payment:
  - d) If the Work is defective, requiring correction or replacement; and/or
  - e) the Contract Price has been reduced by Change Orders.

D. Payment Becomes Due

1. After presentation of the Application for Payment by Owner's representative the amount recommended will become due, and will be paid by Owner to Contractor.

E. Reductions in Payment by Owner

2. In addition to any reductions in payment Owner is entitled to impose a set-off against payment based on any of the following:
  - a) Claims have been made against Owner on account of Contractor's conduct in the performance or furnishing of the Work, or Owner has incurred costs, losses, or damages on account of Contractor's conduct in the performance or furnishing of the Work, including but not limited to claims, costs, losses, or damages from workplace injuries and adjacent property damage.
  - b) Contractor has failed to provide and maintain required bonds or insurance;
  - c) the Work is defective, requiring correction or replacement;
  - d) liquidated damages have accrued as a result of Contractor's failure to achieve final completion of the Work; and/or
  - e) Liens have been filed in connection with the Work.
3. If Owner imposes any set-off against payment, whether based on its own knowledge, Owner will give Contractor immediate written notice stating the reasons for such action and the specific amount of the reduction, and promptly pay Contractor any amount remaining after deduction of the amount so withheld. Owner shall promptly pay Contractor the amount so withheld, or any adjustment thereto agreed to by Owner and Contractor, if Contractor remedies the reasons for such action. The reduction imposed shall be binding on Contractor unless it duly submits a Change Proposal contesting the reduction.

F. Liquidated of Damages

4. The Contractor and Owner agree that in case all the work under the Contract and related documents is not completed within the time limit set forth in the Contract Documents, damage will be sustained by the Owner and that it is and will be impracticable to determine the actual damage sustained by the Owner in the event of and by reason of such delay, it is therefore agreed that the Contractor shall pay to the Owner the sum of Five Hundred Dollars (\$500.00) per day for each calendar day delay of finishing the work in excess of the number of calendar days prescribed in Article 26.

34.05 Substantial Completion

- A. When Contractor considers the entire Work ready for its intended use Contractor shall notify Owner in writing that the entire Work is substantially complete and request that Owner issue a certificate of Substantial Completion. Contractor shall at the same time submit to Owner an initial draft of punch list items to be completed or corrected before final payment.

- B. Promptly after Contractor's notification, Owner's representative and Contractor shall make an inspection of the Work to determine the status of completion. If Owner's representative does not consider the Work substantially complete, Owner will notify Contractor in writing giving the reasons therefor.
- C. If Owner's representative considers the Work substantially complete the Contractor shall promptly begin work on the punch list of items to be completed or corrected prior to final payment.

#### 34.05 Final Inspection

- A. Upon written notice from Contractor that the entire Work or an agreed portion thereof is complete, Owner's representative will promptly make a final inspection with Contractor and will notify Contractor in writing of all particulars in which this inspection reveals that the Work is incomplete or defective. Contractor shall immediately take such measures as are necessary to complete such Work or remedy such deficiencies.

#### 34.06 Final Payment

- A. After Contractor has, in the opinion of Owner's representative, satisfactorily completed all corrections identified during the final inspection and has delivered, in accordance with the Contract Documents, all instructions, schedules, guarantees, and other documents, Contractor may make application for final payment.
  - 1. The final Application for Payment shall be by:
    - a) All documentation called for in the Contract Documents;
    - b) a list of any disputes that Contractor believes are unsettled; and
    - c) complete and legally effective releases or waivers of all Lien rights arising out of the Work, and of Liens filed in connection with the Work.
- B. The acceptance of final payment by Contractor will constitute a waiver by Contractor of all claims and rights against Owner.

#### 34.07 Correction Period

- A. If within three years after the date of completion, any Work is found to be defective, then Contractor shall promptly, without cost to Owner and in accordance with Owner's written instructions Satisfactorily replace or repair defective Work.
- B. If Contractor does not promptly comply with the terms of Owner's written instructions, or in an emergency where delay would cause serious risk of loss or damage, Owner may have the defective Work corrected or repaired or may have the rejected Work removed and replaced. Contractor shall pay all claims, costs, losses, and damages.
- C. Where defective Work (and damage to other Work resulting therefrom) has been corrected or removed and replaced under this paragraph, the correction period hereunder with respect to such Work will be extended for an additional period of one

year after such correction or removal and replacement has been satisfactorily completed.

- D. Contractor's obligations under this paragraph are in addition to all other obligations and warranties. The provisions of this paragraph shall not be construed as a substitute for, or a waiver of, the provisions of any applicable statute of limitation or repose.

## **ARTICLE - 35 SUSPENSION AND TERMINATION OF WORK**

### **35.01 Owner May Terminate for Cause**

- A. The occurrence of any one or more of the following events will constitute a default by Contractor and justify termination for cause:
  - 1. Contractor's persistent failure to perform the Work in accordance with the Contract Documents including, but not limited to, failure to supply sufficient skilled workers or suitable materials or failure to adhere to the Progress Schedule;
  - 2. failure of Contractor to perform or otherwise to comply with a material term of the Contract Documents;
  - 3. Contractor's disregard of Laws or Regulations of any public body having jurisdiction; or
  - 4. Contractor's repeated disregard of the authority of Owner.
- B. Where Contractor's services have been so terminated by Owner, the termination will not affect any rights or remedies of Owner against Contractor then existing or which may thereafter accrue, or any rights or remedies of Owner against Contractor or any surety under any payment bond or performance bond. Any retention or payment of money due Contractor by Owner will not release Contractor from liability.

### **35.02 Owner May Terminate For Convenience**

- A. Upon seven days written notice to Contractor Owner may, without cause and without prejudice to any other right or remedy of Owner, terminate the Contract. In such case, Contractor shall be paid for:
  - 1. Completed and acceptable Work executed in accordance with the Contract Documents prior to the effective date of termination.
- B. Contractor shall not be paid on account of loss of anticipated overhead, profits, or revenue, or other economic loss arising out of or resulting from such termination.

## **ARTICLE 36 – FINAL RESOLUTION TO DISPUTES**

### **36.01 Methods and Procedures**

- A. Disputes Subject to Final Resolution: The following disputed matters are subject to final resolution under the provisions of this Article:
  - 1. A timely appeal of an approval in part and denial in part of a Claim, or of a denial in full; and

2. Disputes between Owner and Contractor concerning the Work or obligations under the Contract Documents, and arising after final payment has been made.
- B. Final Resolution of Disputes: For any dispute subject to resolution under this Article, Owner or Contractor may:
1. Agree with the other party to submit the dispute to another dispute resolution process; or
  2. if no dispute resolution process is provided for give written notice to the other party of the intent to submit the dispute to a court of competent jurisdiction.

## **ARTICLE 37 – MISCELLANEOUS**

### **37.01 Giving Notice**

- A. Whenever any provision of the Contract Documents requires the giving of written notice, it will be deemed to have been validly given if:
1. Delivered in person, by a commercial courier service or otherwise, to the individual or to a member of the firm or to an officer of the corporation for which it is intended; or
  2. Delivered at or sent by registered or certified mail, postage prepaid, to the last business address known to the sender of the notice.

### **37.02 Computation of Times**

- A. When any period is referred to in the Contract by days, it will be computed to exclude the first and include the last day of such period. If the last day of any such period falls on a Saturday or Sunday or on a day made a legal holiday by the law of the applicable jurisdiction, such day will be omitted from the computation.

### **37.03 Cumulative Remedies**

- A. The duties and obligations imposed by these General Conditions and the rights and remedies available hereunder to the parties hereto are in addition to, and are not to be construed in any way as a limitation of, any rights and remedies available to any or all of them which are otherwise imposed or available by Laws or Regulations, by special warranty or guarantee, or by other provisions of the Contract. The provisions of this paragraph will be as effective as if repeated specifically in the Contract Documents in connection with each particular duty, obligation, right, and remedy to which they apply.

Project Number: 2024-07-4290  
SCIIP Grant Number: A-23-C145

**CERTIFICATE OF DRUG FREE WORKPLACE CERTIFICATION**

In order to have a drug-free workplace, a business shall:

Publish a statement notifying employees that the unlawful, manufacture, distribution, dispensing, possession, or use of controlled substances is prohibited in the workplace and specifying the actions that shall be taken against employees for violation of such prohibition.

Inform employees about the dangers of drug abuse in the workplace, the business's policy of maintaining a drug-free workplace, any available drug counseling, rehabilitation, and employee assistance programs, and the penalties that may be imposed upon employees for drug abuse violations.

As a condition of working on the commodities or contractual services then under bid, the employee shall notify the employer of any conviction of, or plea of guilty or nolo contendere to, any violation of any controlled substance law of the United States or any State, for a violation occurring in the workplace no later than five (5) days after such conviction.

Impose a sanction on, or require satisfactory participation in a drug abuse assistance or rehabilitation program if such is available in the employee's community, by any employee who is so convicted.

Make a good faith effort to continue to maintain a drug-free workplace through implementation of this section.

As the person authorized to sign this statement, I certify that this firm complies fully with the above requirements.

Date: \_\_\_\_\_

Business Address: \_\_\_\_\_

Authorized Signature: \_\_\_\_\_

Print Name: \_\_\_\_\_

Title: \_\_\_\_\_

## LOBBYING CERTIFICATION

The undersigned certifies, to the best of his or her knowledge and belief, that:

(1) No Federal appropriated funds have been paid or will be paid, by or on behalf of the undersigned, to any person for influencing or attempting to influence an officer or employee of any agency, a Member of Congress, an officer or employee of Congress, or an employee of a Member of Congress in connection with the awarding of any Federal contract, the making of any Federal grant, the making of any Federal loan, the entering into of any cooperative agreement, and the extension, continuation, renewal, amendment, or modification of any Federal contract, grant, loan, or cooperative agreement.

(2) If any funds other than Federal appropriated funds have been paid or will be paid to any person for influencing or attempting to influence an officer or employee of any agency, a Member of Congress, an officer or employee of Congress, or an employee of a Member of Congress in connection with this Federal contract, grant, loan, or cooperative agreement, the undersigned shall complete and submit Standard Form-LLL, "Disclosure Form to Report Lobbying," in accordance with its instructions.

(3) The undersigned shall require that the language of this certification be included in the award documents for all sub-awards at all tiers (including subcontracts, sub-grants, and contracts under grants, loans, and cooperative agreements) and that all sub-recipients shall certify and disclose accordingly.

This certification is a material representation of fact upon which reliance was placed when this transaction was made or entered into. Submission of this certification is a prerequisite for making or entering into this transaction imposed by section 1352, title 31,

U.S. Code. Any person who fails to file the required certification shall be subject to a civil penalty of not less than \$10,000 and not more than \$100,000 for each such failure.

Date: \_\_\_\_\_

Business Address: \_\_\_\_\_

Authorized Signature: \_\_\_\_\_

Print Name: \_\_\_\_\_

Title: \_\_\_\_\_

Project Number: 2024-07-4290

**EEO CONTRACTOR AGREEMENT**

**NON-DISCRIMINATION CLAUSE:** Contractor shall not discriminate against any employee or applicant for employment on any basis prohibited by law. Contractor shall provide equal opportunity in all employment practices.

**EQUAL EMPLOYMENT OPPORTUNITY (EEO):** Contractor has received, read, understands and agrees to be bound by the Equal Employment Opportunity Program of {Insert Name of Company} provided with the proposal package. {Insert Name of Company} and Contractor agree that compliance with EEO provisions will be implemented, monitored, and reviewed by {Insert Name of Company} Equal Opportunity Contracting Program (EOCP) staff.

**EQUAL OPPORTUNITY CONTRACTING:** Contractor has received, read, understands and agrees to be bound by the Equal Opportunity Contracting Program requirements described in the proposal package.

Contractor agrees to insert equal opportunity compliance language in all subcontracts for any work covered by this Agreement so that such provisions will be binding upon each subcontractor.

Project Name: \_\_\_\_\_ Bid Number: \_\_\_\_\_

Company Name: \_\_\_\_\_ Date: \_\_\_\_\_

\_\_\_\_\_  
Authorized Signature

\_\_\_\_\_  
Print Authorized Signature Name



**EXHIBIT A**  
**FEDERAL COMPLIANCE PROVISIONS**

Project Number: 2024-07-4290  
SCIIP Grant Number: A-23-C145

Program (SCIIP), which is administered by the South Carolina Rural Infrastructure Authority (RIA) and funded by federal State and Local Fiscal Recovery Funds (SLFRF) through the American Rescue Plan Act (ARPA). All federal SLFRF requirements and SCIIP requirements will apply to the contract. All contractors and subcontractors are required to be registered in the federal System for Award Management (SAM) and may not be debarred from doing business with the federal government. Respondents on this work will be required to comply with all applicable federal regulations, including those listed herein.

In the event of a conflict between these Federal Provisions, the body of the contract, or any attachments or exhibits incorporated into and made a part of the contract, the Federal Provisions shall control.

**Contract Work Hours and Safety Standards Act**

The Contractor must comply with 40 U.S.C. 3702 and 3704, as supplemented by Department of Labor regulations (29 CFR Part 5). Under 40 U.S.C. 3702 of the Act, each Contractor must be required to compute the wages of every mechanic and laborer on the basis of a standard work week of 40 hours. Work in excess of the standard work week is permissible provided that the worker is compensated at a rate of not less than one and a half times the basic rate of pay for all hours worked in excess of 40 hours in the work week. Requirements of 40 U.S.C. 3704 are applicable to construction work and provide that no laborer or mechanic must be required to work in surroundings or under working conditions which are unsanitary, hazardous, or dangerous. These requirements do not apply to the purchases of supplies or materials or articles ordinarily available on the open market, or contracts for transportation or transmission of intelligence.

**Administrative, Contractual, and Legal Remedies**

In addition to any of the remedies described elsewhere in the contract, if the contractor materially fails to comply with the terms and conditions of this contract, including any federal or state statutes, rules or regulations, applicable to this contract, RIA or the Grantee may take one or more of the following actions:

- a) Temporarily withhold payments pending correction of the deficiency by the contractor;
- b) Disallow (that is, deny both use of funds and any applicable matching credit for) all or part of the cost of the activity or action not in compliance;
- c) Wholly or partly suspend or terminate this Contract; and
- d) Take other remedies that may be legally available.

The remedies identified above, do not preclude the contractor from being subject to debarment and suspension under Presidential Executive Orders 12549 and 12689. The Grantee shall have the right to demand a refund, either in whole or part, of the funds provided to the contractor for noncompliance with the terms of this Contract.

### **Terms and Conditions for Federal Contracts**

The contract may be terminated in whole or in part as follows:

- a) By the Grantee, if a contractor fails to comply with the terms and conditions of the SCIIP award;
- b) By the Grantee, to the greatest extent authorized by law, if an award no longer effectuates the program goals or agency priorities;
- c) By the Grantee with the consent of the contractor, in which case the two parties must agree upon the termination conditions, including the effective date and, in the case of partial termination, the portion to be terminated;
- d) By the Grantee upon written notification setting forth the reasons for such termination, the effective date, and, in the case of partial termination, the portion to be terminated. However, if the Grantee determines in the case of partial termination that the reduced or modified portion of the contract will not accomplish the purposes for which the contract was made, the Grantee may terminate the contract in its entirety; or
- e) By the Grantee pursuant to termination provisions included in the SCIIP award.

### **Clean Air Act and Federal Water Pollution Control Act**

- A. The Grantee and its Contractors agree to comply with all applicable standards, orders, and regulations issued pursuant to the Clean Air Act, as amended, 42 U.S.C. 7401 *et seq.* Grantee and its Contractors agree to report each violation to assure notification to Treasury and the appropriate Environmental Protection Agency Regional Office. Grantees and its Contractors agree to include these requirements in each subcontract exceeding \$150,000 financed, in whole or in part, with SCIIP funds.
- B. The Grantee and its Contractors agree to comply with all applicable standards, orders, and regulations issued pursuant to the Federal Water Pollution Control Act, as amended, 33 U.S.C. 1251 *et seq.* Grantee and its contractors agree to report each violation to assure notification to Treasury and the appropriate Environmental Protection Agency Regional Office. Grantee and its Contractors agree to include these requirements in each subcontract exceeding \$150,000 financed, in whole or in part, with SCIIP funds.

### **Procurement of Recovered Materials**

The Grantee and its Contractors shall make maximum use of products containing recovered materials that are EPA-designated items, unless the product cannot (1) be acquired competitively within a timeframe providing for compliance with the project performance schedule, (2) meet project performance requirements, or (3) be acquired at a reasonable price. Information about this requirement, along with the list of EPA-designated items, is available on [EPA's website](#). The Grantee and its Contractors also agree to comply with all other applicable requirements of Section 6002 of the Solid Waste Disposal Act.

### **Civil Rights Requirements**

Recipients of Federal financial assistance from the Treasury are required to meet legal requirements relating to nondiscrimination and nondiscriminatory use of Federal funds. Those requirements include ensuring that entities receiving federal financial assistance from the Treasury do not deny benefits or services, or otherwise discriminate on the basis of race, color, national origin (including limited English proficiency), disability, age, or sex (including sexual orientation and gender identity.) Statutes and regulations prohibiting discrimination applicable to this award include, without limitation, the following:

- a) **Title VI of the Civil Rights Act of 1964** (42 U.S.C. 2000d et seq.) and Treasury's implementing regulations at 31 CFR Part 22, which prohibit discrimination on the basis of race, color, or national origin under programs or activities receiving federal financial assistance;
- b) **The Fair Housing Act, Title VIII of the Civil Rights Act of 1968** (42 U.S.C. 3601et seq.), which prohibits discrimination in housing on the basis of race, color, religion, national origin, sex, familial status, or disability;
- c) **Section 504 of the Rehabilitation Act of 1973, as amended** (29 U.S.C. 794), which prohibits discrimination on the basis of disability under any program or activity receiving federal financial assistance;
- d) The **Age Discrimination Act of 1975, as amended** (42 U.S.C. 6101 et seq.), and Treasury's implementing regulations at 31 CFR Part 23, which prohibit discrimination on the basis of age in programs or activities receiving federal financial assistance; and
- e) **Title II of the Americans with Disabilities Act of 1990, as amended** (42 U.S.C. 12101 et seq.), which prohibits discrimination on the basis of disability under programs, activities, and services provided or made available by RIA and local governments or instrumentalities or agencies thereto.

## Equal Opportunity Clause

During the performance of this contract, the contractor agrees as follows:

The contractor will not discriminate against any employee or applicant for employment because of race, color, religion, sex, sexual orientation, gender identity, or national origin. The Contractor will take affirmative action to ensure that applicants are employed, and that employees are treated during employment without regard to their race, color, religion, sex, sexual orientation, gender identity, or national origin. Such action shall include, but not be limited to the following:

- A. Employment, upgrading, demotion, or transfer; recruitment or recruitment advertising; layoff or termination; rates of pay or other forms of compensation; and selection for training, including apprenticeship. The contractor agrees to post in conspicuous places, available to employees and applicants for employment, notices to be provided setting forth the provisions of this nondiscrimination clause. The contractor will, in all solicitations or advertisements for employees placed by or on behalf of the contractor, state that all qualified applicants will receive consideration for employment without regard to race, color, religion, sex, sexual orientation, gender identity, or national origin.
- B. The contractor will not discharge or in any other manner discriminate against any employee or applicant for employment because such employee or applicant has inquired about, discussed, or disclosed the compensation of the employee or applicant or another employee or applicant. This provision shall not apply to instances in which an employee who has access to the compensation information of other employees or applicants as a part of such employee's essential job functions discloses the compensation of such other employees or applicants to individuals who do not otherwise have access to such information, unless such disclosure is in response to a formal complaint or charge, in furtherance of an investigation, proceeding, hearing, or action, including an investigation conducted by the employer, or is consistent with the contractor's legal duty to furnish information.
  - i. **The Fair Housing Act, Title VIII of the Civil Rights Act of 1968** (42 U.S.C. 3601et seq.), which prohibits discrimination in housing on the basis of race, color, religion, national origin, sex, familial status, or disability;
  - ii. **Section 504 of the Rehabilitation Act of 1973, as amended** (29 U.S.C. 794), which prohibits discrimination on the basis of disability under any program or activity receiving federal financial assistance;
  - iii. **The Age Discrimination Act of 1975, as amended** (42 U.S.C. 6101 et seq.), and Treasury's implementing regulations at 31 CFR Part 23, which prohibit discrimination on the basis of age in programs or activities receiving federal financial assistance; and
  - iv. **Title II of the Americans with Disabilities Act of 1990, as amended** (42 U.S.C. 12101 et seq.), which prohibits discrimination on the basis of disability under programs, activities, and services provided or made available by RIA and local

governments or instrumentalities or agencies thereto.

- C. The contractor will send to each labor union or representative of workers with which he has a collective bargaining contract or other contract or understanding, a notice to be provided advising the said labor union or workers' representatives of the contractor's commitments under this section, and shall post copies of the notice in conspicuous places available to employees and applicants for employment.
- D. The contractor will comply with all provisions of Executive Order 11246 of September 24, 1965, and of the rules, regulations, and relevant orders of the Secretary of Labor.
- E. The contractor will furnish all information and reports required by Executive Order 11246 of September 24, 1965, and by rules, regulations, and orders of the Secretary of Labor, or pursuant thereto, and will permit access to his books, records, and accounts by the administering agency and the Secretary of Labor for purposes of investigation to ascertain compliance with such rules, regulations, and orders.
- F. In the event of the contractor's noncompliance with the nondiscrimination clauses of this contract or with any of the said rules, regulations, or orders, this contract may be canceled, terminated, or suspended in whole or in part and the contractor may be declared ineligible for further Government contracts or federally assisted construction contracts in accordance with procedures authorized in Executive Order 11246 of September 24, 1965, and such other sanctions may be imposed and remedies invoked as provided in Executive Order 11246 of September 24, 1965, or by rule, regulation, or order of the Secretary of Labor, or as otherwise provided by law.

**2024 WASTEWATER INTERCEPTOR PIPELINE & MANHOLE REHABILITATION PROJECT  
NOTICE OF INTENT TO AWARD**

Project Number: 2024-07-4290  
SCIIP Grant Number: A-23-C145

Date: \_\_\_\_\_

City of North Augusta  
100 Georgia Avenue  
North Augusta, SC 29841

Please take notice, that pursuant to the Instruction for Bidders issued by the City of North Augusta (owner) in connection with the above referenced Project, this shall constitute the Owner's Notice of Intent to Award the Contract for the 2024 Wastewater Interceptor Pipeline and Manhole Rehabilitation Project. The Owner intends to award the contract for the project in the amount of \$ \_\_\_\_\_ to \_\_\_\_\_, as the responsible bidder. Approval of the Contract for the Project will be considered by administrative staff of the South Carolina Infrastructure Investment Program (SCIIP).

**Protest of Award**

Any Bidder who is adversely affected or aggrieved by the Owner Notice of Intent to Award to another Bidder shall have three (3) days after Notice of Intent to Award to submit to the Owner a written protest of the award. The written protest shall specify the grounds upon which the protest is based. The Owner will not accept protests submitted after the time period established.

**2024 WASTEWATER INTERCEPTOR PIPELINE & MANHOLE REHABILITATION PROJECT  
NOTICE OF AWARD**

Project Number: 2024-07-4290  
SCIIP Grant Number: A-23-C145

TO:

FROM: City of North Augusta (OWNER)  
100 Georgia Avenue  
North Augusta, South Carolina 29841

You are hereby notified that the Bid submitted by you for the above named project in response to the City of Concord's Invitation to Bid dated \_\_\_\_\_ in the amount of \$ \_\_\_\_\_ has been accepted.

You are hereby required to execute the formal AGREEMENT with the City of North Augusta (Owner) and to furnish any and all Contractor's Bond(s), Certificate of Insurance with other documents pertaining to the work as designated by the City of North Augusta.

If you fail to execute said AGREEMENT and to furnish this and any other required documents pertaining to the work within ten (10) days from the date of delivery of this NOTICE OF AWARD, said Owner will be entitled to consider all your rights arising out of the Owner's acceptance of your Bid as abandoned and to award the work covered by your proposal to another, or to re-Bid the work or otherwise dispose thereof as the Owner may see fit.

Dated this the \_\_\_\_\_ day of \_\_\_\_\_, 20\_\_\_\_\_

City of North Augusta

Contractor

By: \_\_\_\_\_

By: \_\_\_\_\_

Title: \_\_\_\_\_

Title: \_\_\_\_\_

Receipt of the above NOTICE OF AWARD is hereby acknowledged this the \_\_\_\_\_ day of \_\_\_\_\_, 2024.

**2024 WASTEWATER INTERCEPTOR PIPELINE & MANHOLE REHABILITATION PROJECT  
NOTICE TO PROCEED**

TO:

FROM: City of North Augusta (OWNER)  
100 Georgia Avenue  
North Augusta, South Carolina 29841

Project Number: 2024-07-4290  
SCIIP Grant Number: A-23-C145

Contract Amount: \$ \_\_\_\_\_

You are hereby notified to commence work on or before the \_\_\_\_\_ day of \_\_\_\_\_, 2024, , and are to fully complete the work by \_\_\_\_\_ day of \_\_\_\_\_, 2024.

Dated this the \_\_\_\_\_ day of \_\_\_\_\_, 20\_\_\_\_\_

By: \_\_\_\_\_

By: \_\_\_\_\_

Title: \_\_\_\_\_

Title: \_\_\_\_\_

Receipt of the above NOTICE OF AWARD is hereby acknowledged this the \_\_\_\_\_ day of \_\_\_\_\_, 2024.



**2024 WASTEWATER INTERCEPTOR PIPELINE & MANHOLE REHABILITATION PROJECT  
CONTRACTOR PROGRESS PAYMENT**

Project Number: 2024-07-4290

SCIIP Grant Number: A-23-C145

Date: \_\_\_\_\_

Owner: \_\_\_\_\_

Contractor: \_\_\_\_\_

Pay Request No. \_\_\_\_\_

Total Original Contract	\$
Total Change Orders	\$
Total Contract to Date	\$
Invoice Total	\$
Less Retainage 10%	\$
<b>Total Payment Due</b>	<b>\$</b>
Total Estimated Balance	\$

<p align="center"><b>Contractor's Certification</b></p> <p>The undersigned contractor certifies that to the best of their knowledge, information, and belief the work covered by the Application for Payment has been completed in accordance with the Contract Documents</p> <p>Title: _____</p> <p>By: _____</p> <p>Date: _____</p>	<p align="center"><b>City of North Augusta Approvals</b></p> <p><u>Director of Public Services</u></p> <p>By: _____</p> <p>Date: _____</p> <p><u>Director of Finance</u></p> <p>By: _____</p> <p>Date: _____</p> <p><u>City Administrator</u></p> <p>By: _____</p> <p>Date: _____</p>
---	---



**2024 WASTEWATER INTERCEPTOR PIPELINE & MANHOLE REHABILITATION PROJECT  
APPLICATION FOR SUBSTANTIAL COMPLETION**

Project Number: 2024-07-4290  
SCIIP Grant Number: A-23-C145

Date \_\_\_\_\_

Owner: \_\_\_\_\_

Contractor: \_\_\_\_\_

“Substantial Completion” refers to designated work being sufficiently complete, in accordance with the contract documents, such that the Owner may occupy and utilize the work for its intended purpose without disruption of significant interference by the Contractor in completing or correcting any remaining portions of the work.

Owner will provide the contractor with a Punch List of items if any, to be completed or corrected prior to the Owner’s issuing of the final payment. The Punch List does not alter the Contractor’s responsibility to complete or correct all work in full compliance with the contract documents.

Contract Date: \_\_\_\_\_

Denied: \_\_\_\_\_

Approved: \_\_\_\_\_

City of North Augusta

Contractor

By: \_\_\_\_\_

By: \_\_\_\_\_

Title: \_\_\_\_\_

Title: \_\_\_\_\_

**PROJECT LOCATION OF WORK SITE MAPS 1-19**

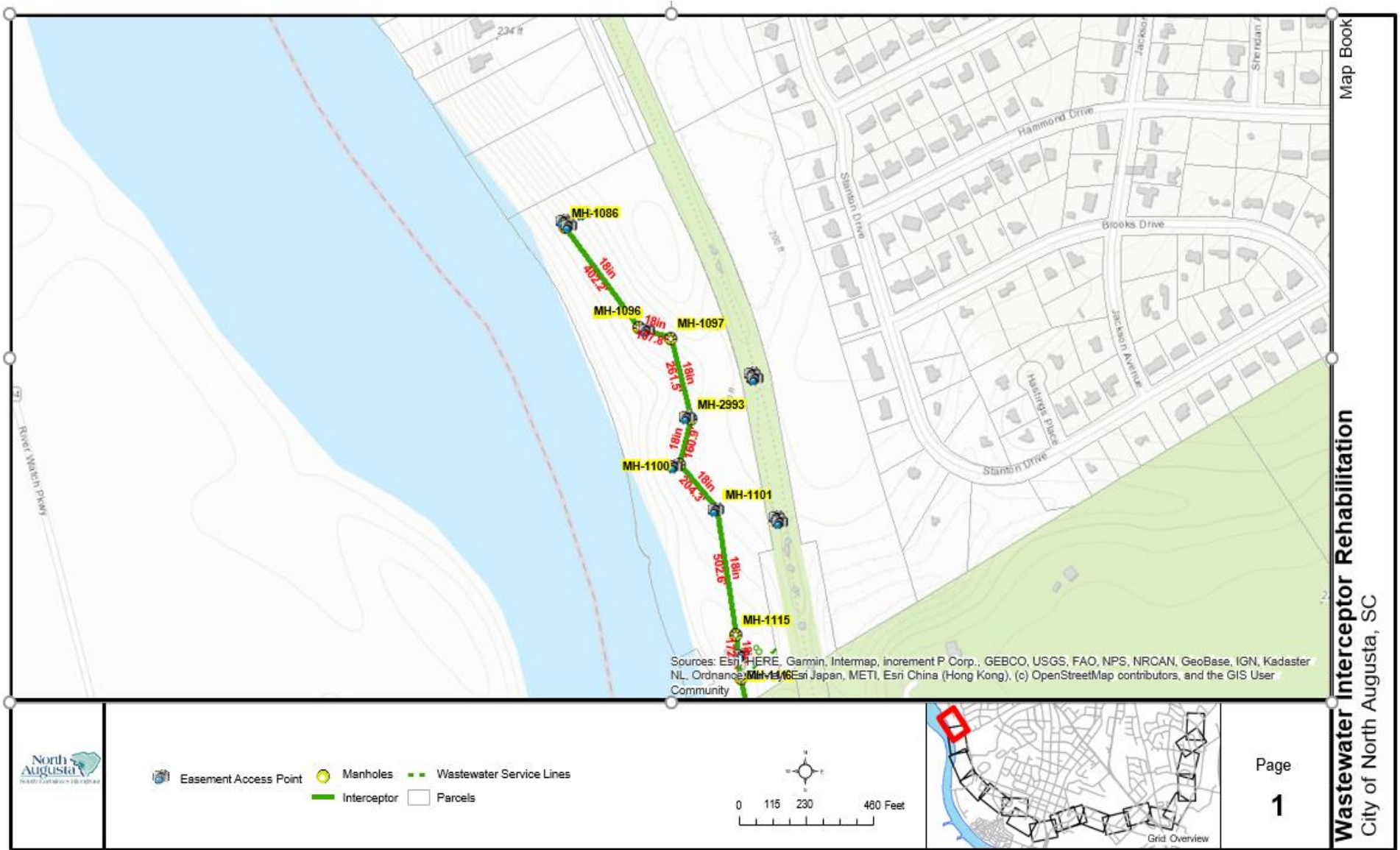

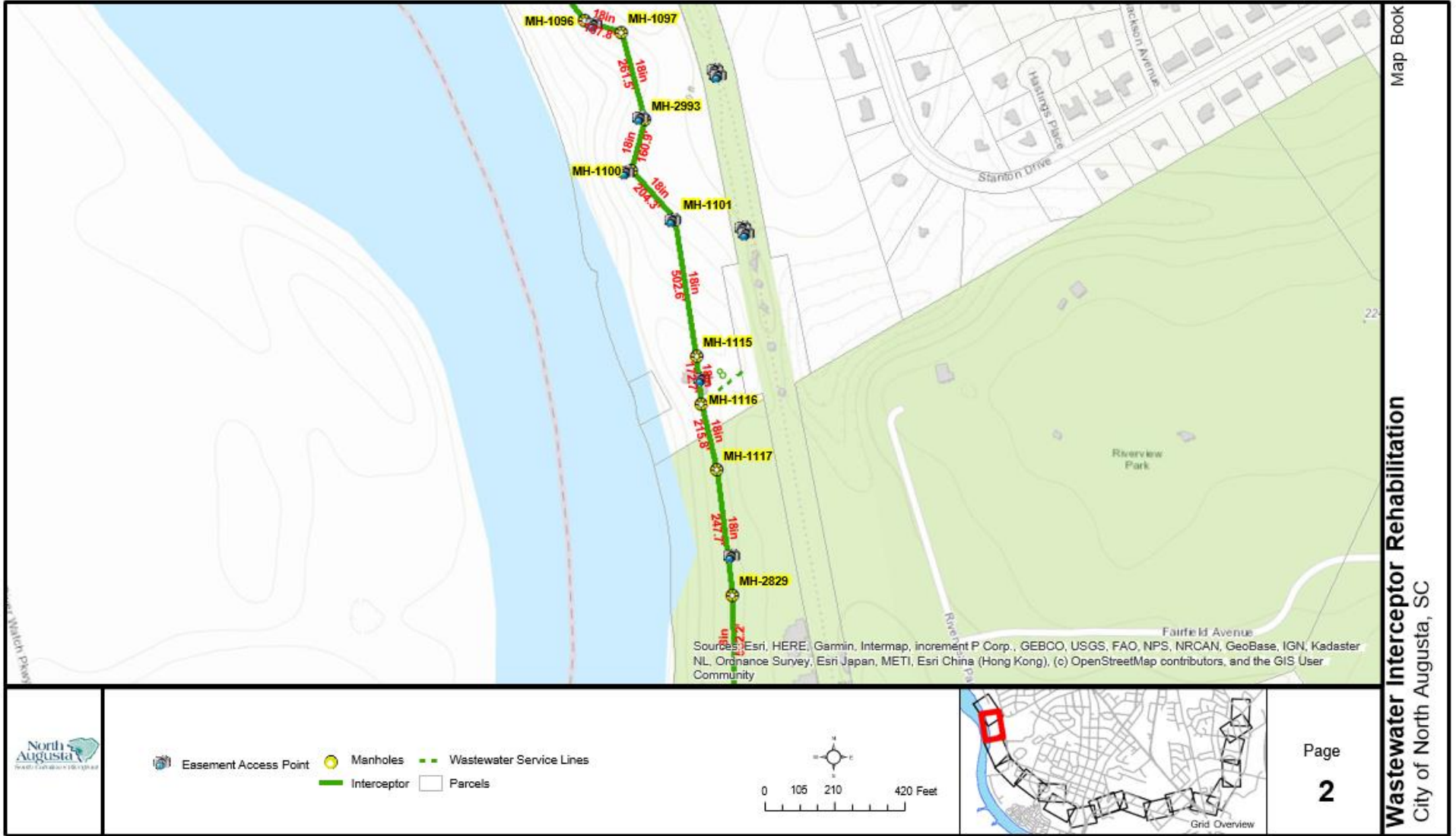

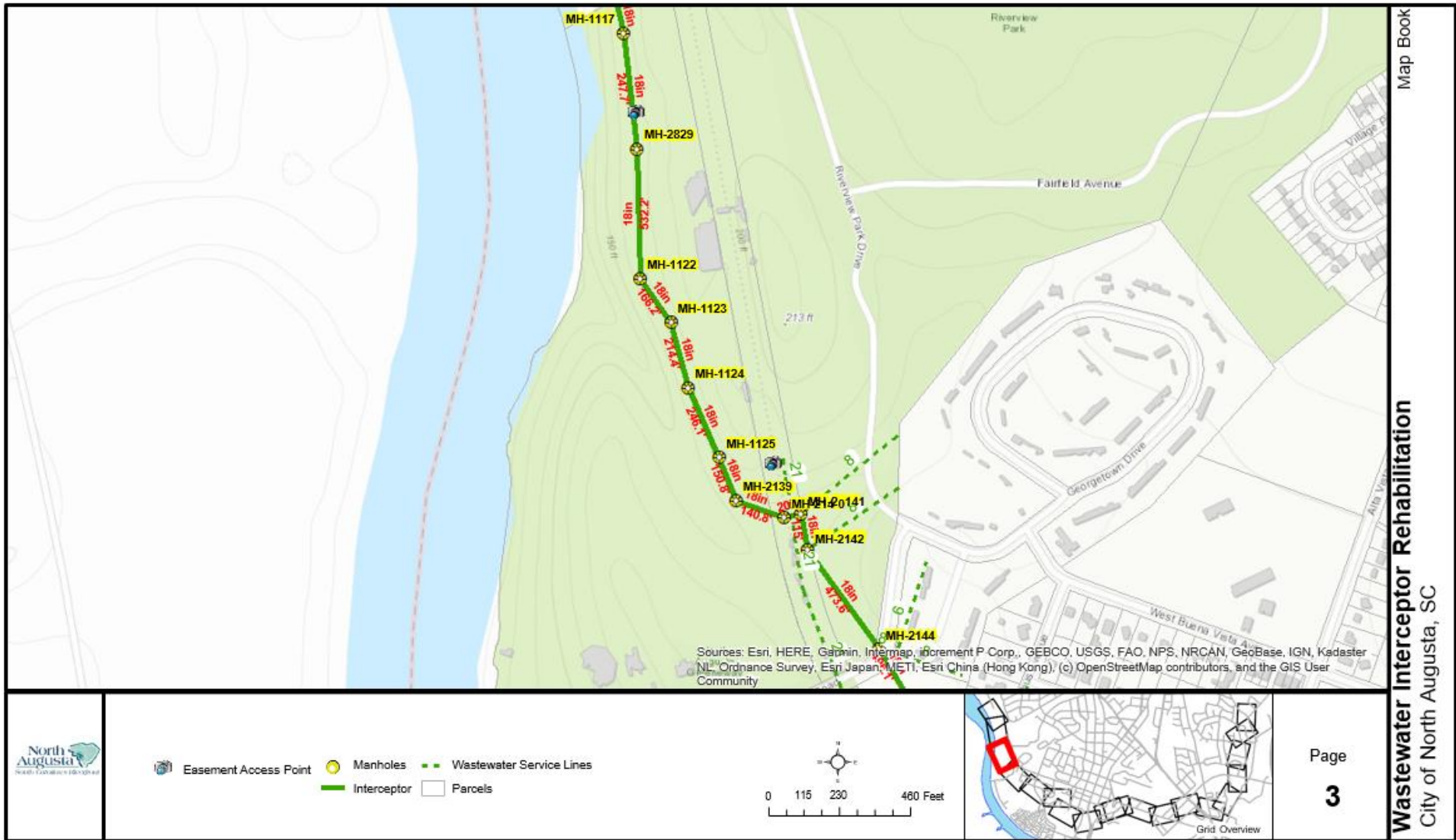



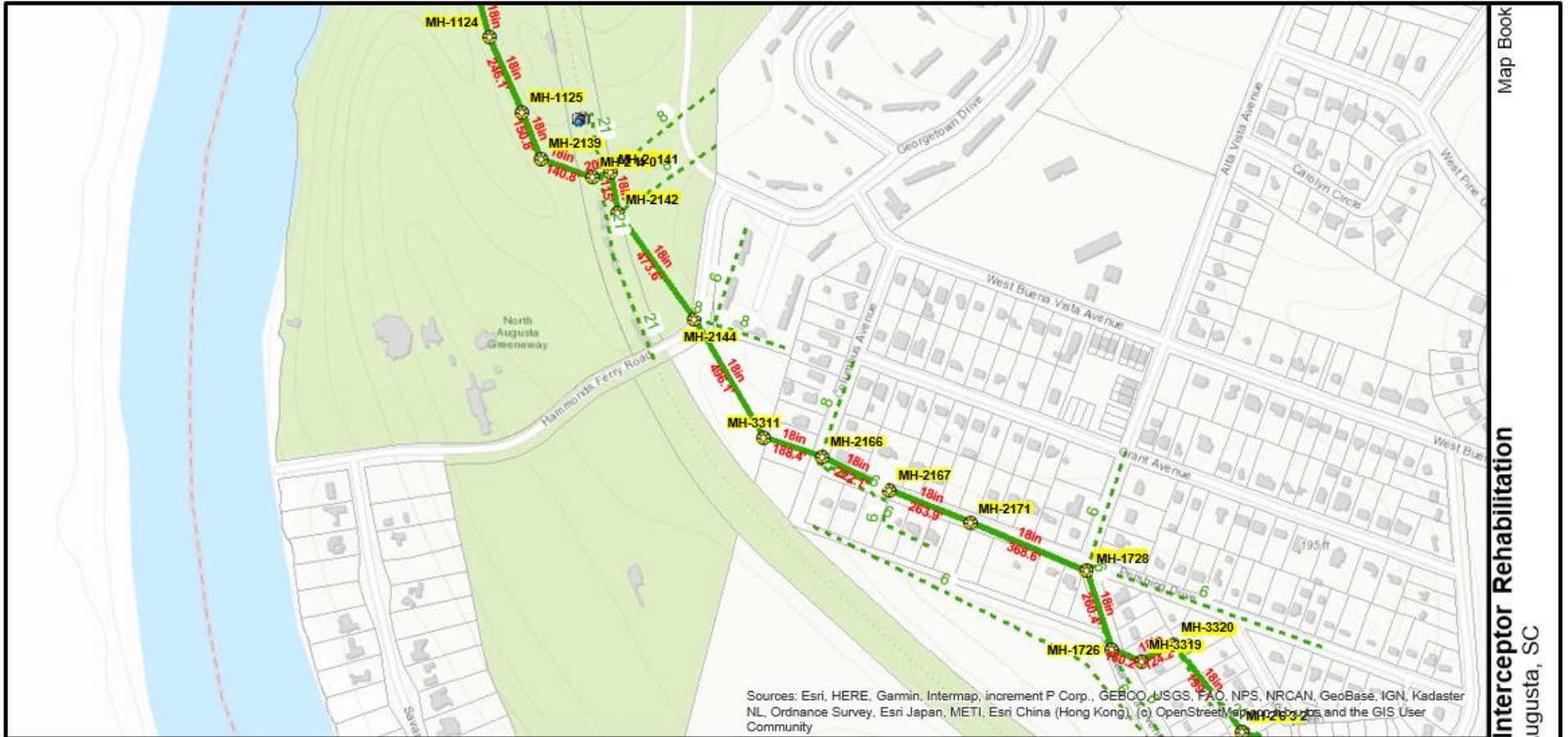

- Easement Access Point
- Manholes
- Wastewater Service Lines
- Interceptor
- Parcels

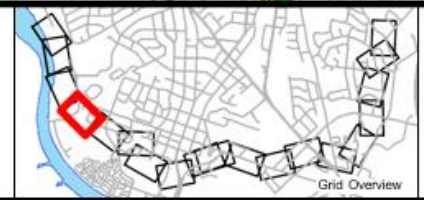
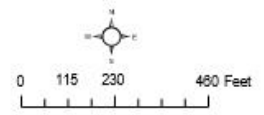

Page  
**4**



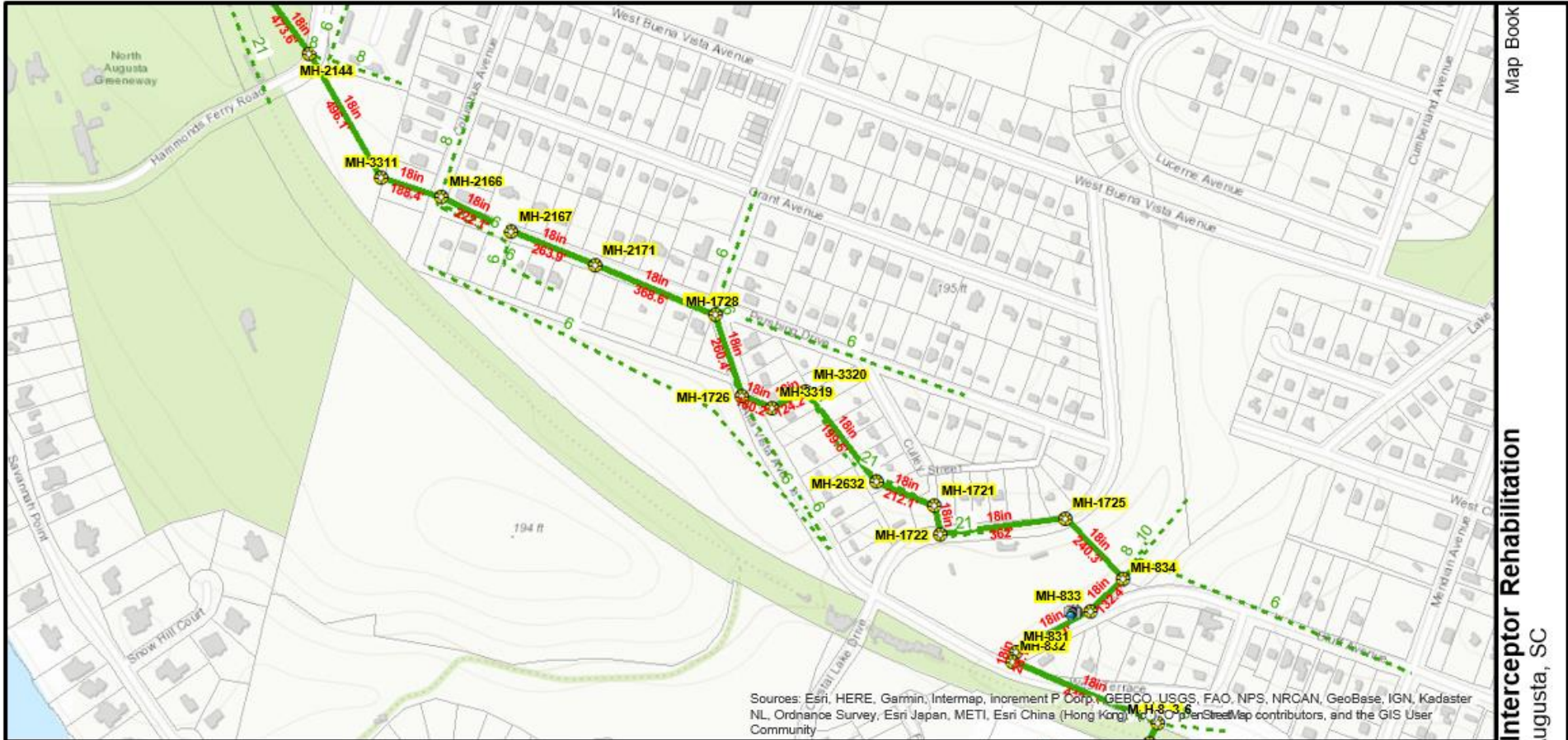

Sources: Esri, HERE, Garmin, Intermap, increment P Corp., GEBCO, USGS, FAO, NPS, NRCAN, GeoBase, IGN, Kadaster NL, Ordnance Survey, Esri Japan, METI, Esri China (Hong Kong), Swisstopo, Mapbox Contributors, and the GIS User Community



- Easement Access Point
- Manholes
- Wastewater Service Lines
- Interceptor
- Parcels

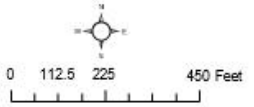

Page  
**5**

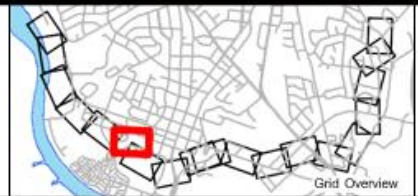
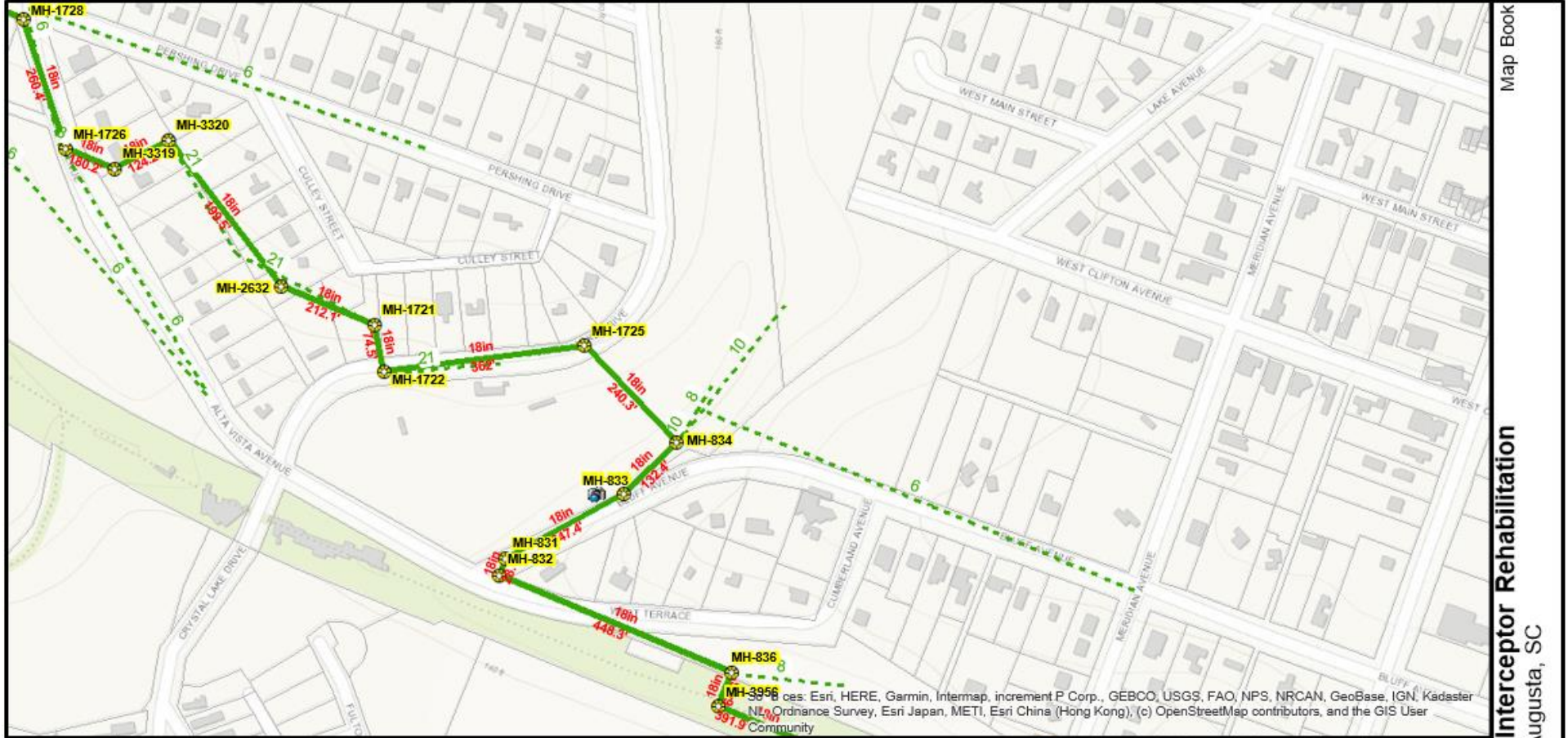

Page  
**6**



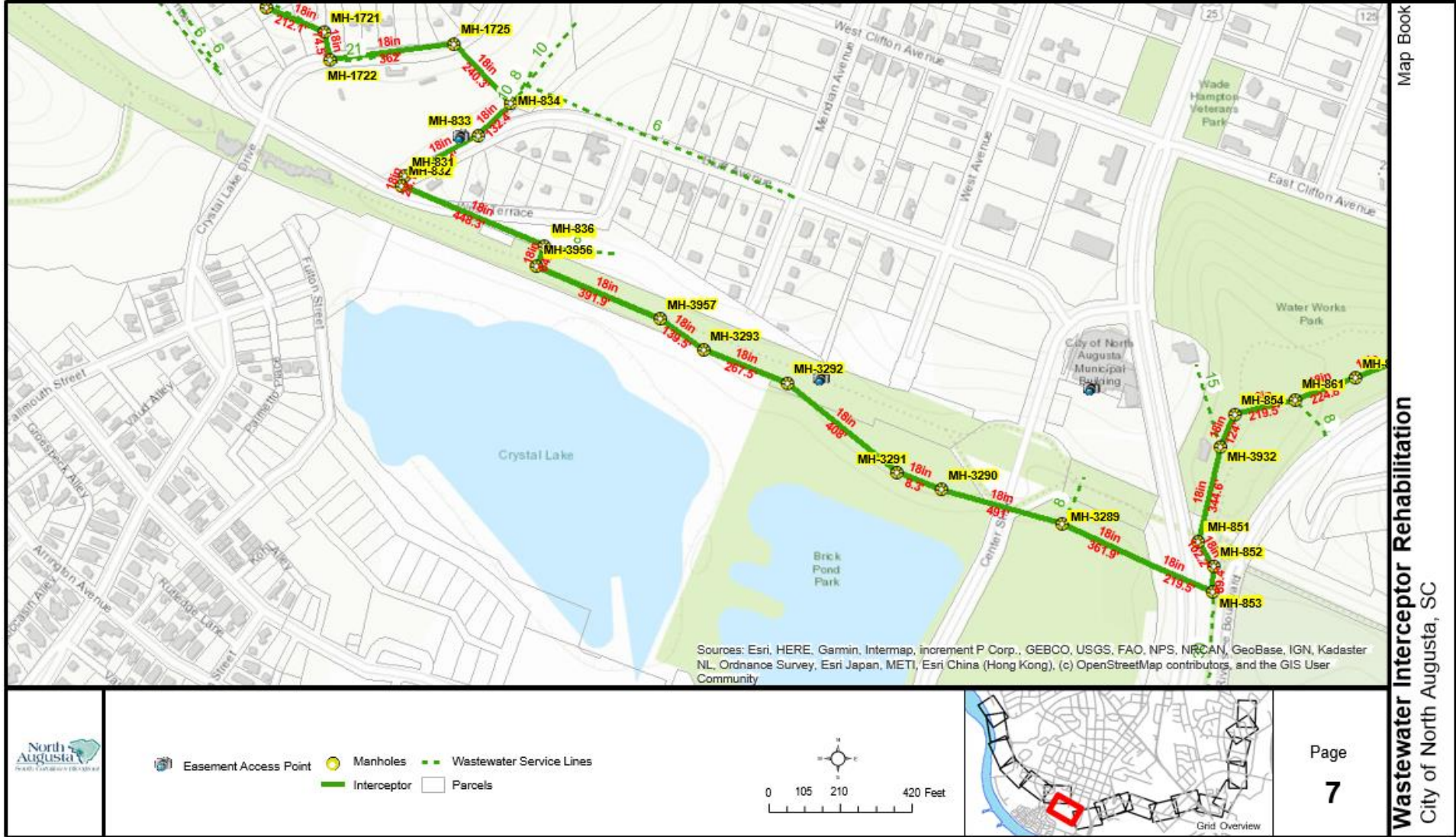

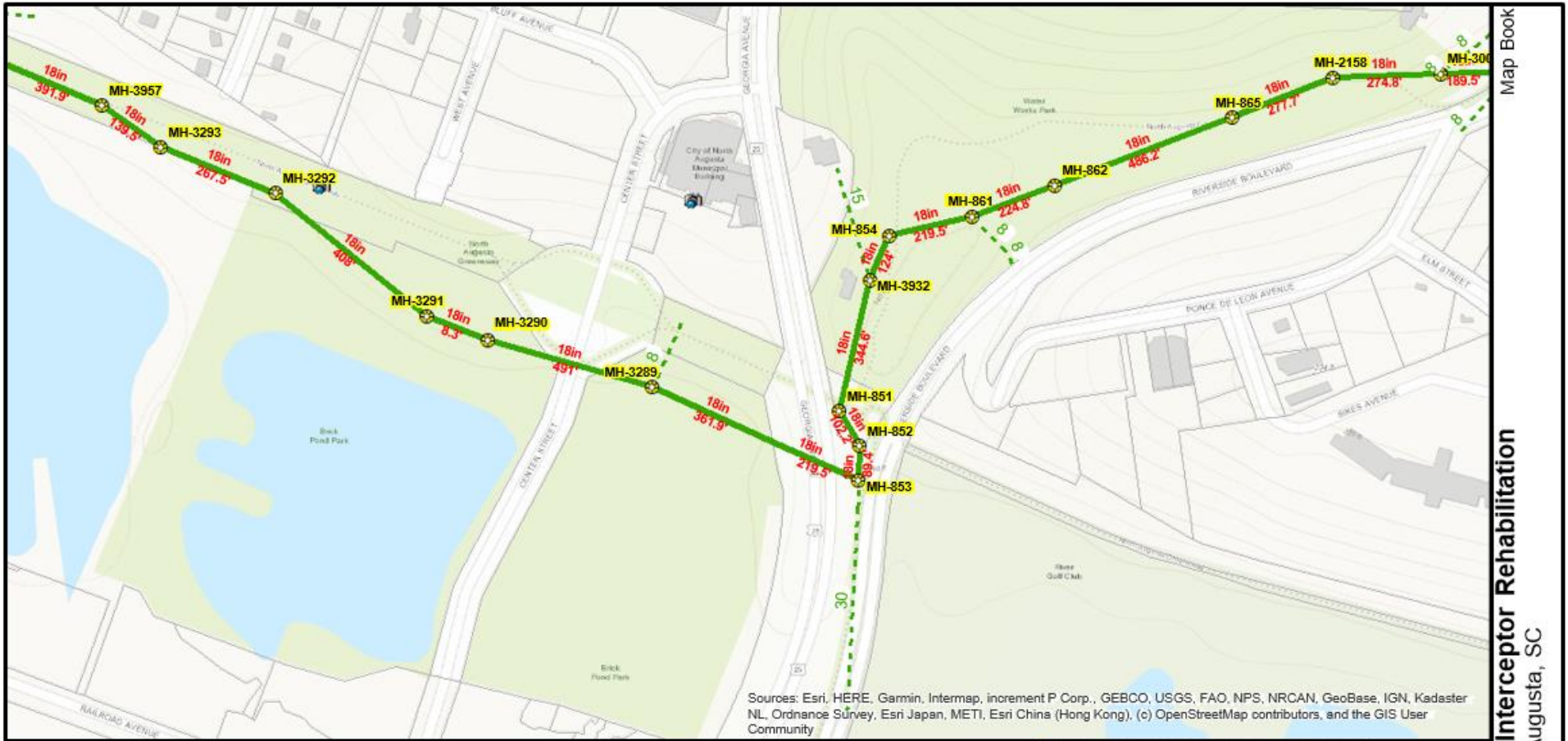

Sources: Esri, HERE, Garmin, Intermap, incorement P Corp., GEBCO, USGS, FAO, NPS, NRCAN, GeoBase, IGN, Kadaster NL, Ordnance Survey, Esri Japan, METI, Esri China (Hong Kong), (c) OpenStreetMap contributors, and the GIS User Community



- Easement Access Point
- Manholes
- Wastewater Service Lines
- Interceptor
- Parcels

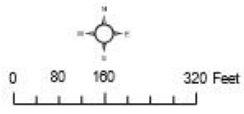

Page  
**8**



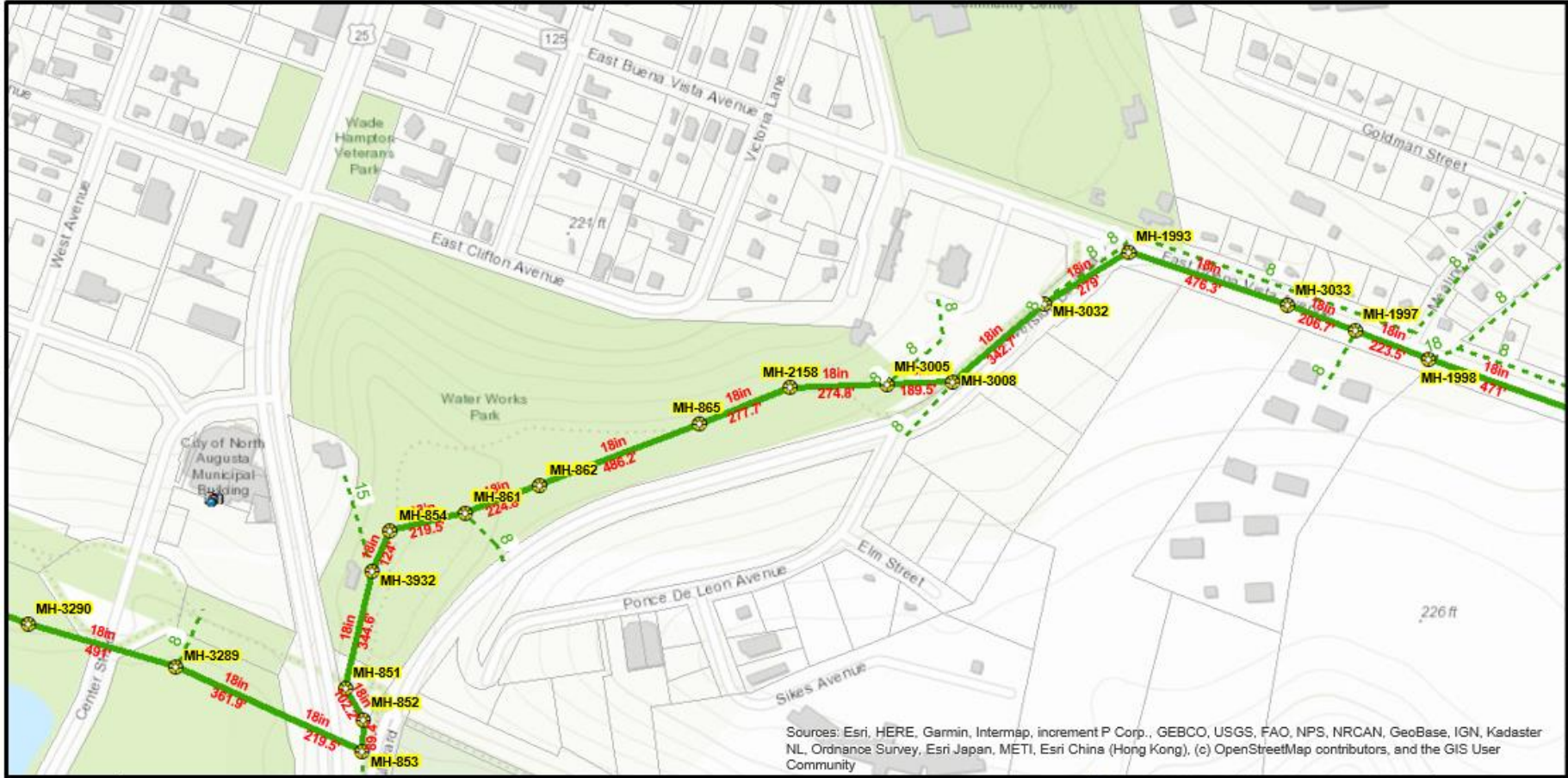

Sources: Esri, HERE, Garmin, Intermap, increment P Corp., GEBCO, USGS, FAO, NPS, NRCAN, GeoBase, IGN, Kadaster NL, Ordnance Survey, Esri Japan, METI, Esri China (Hong Kong), (c) OpenStreetMap contributors, and the GIS User Community



- Easement Access Point
- Manholes
- Wastewater Service Lines
- Interceptor
- Parcels

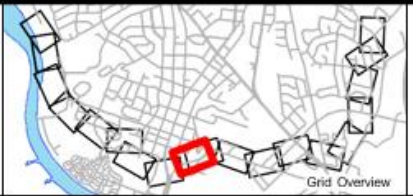
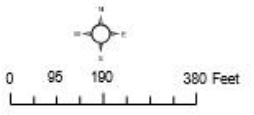

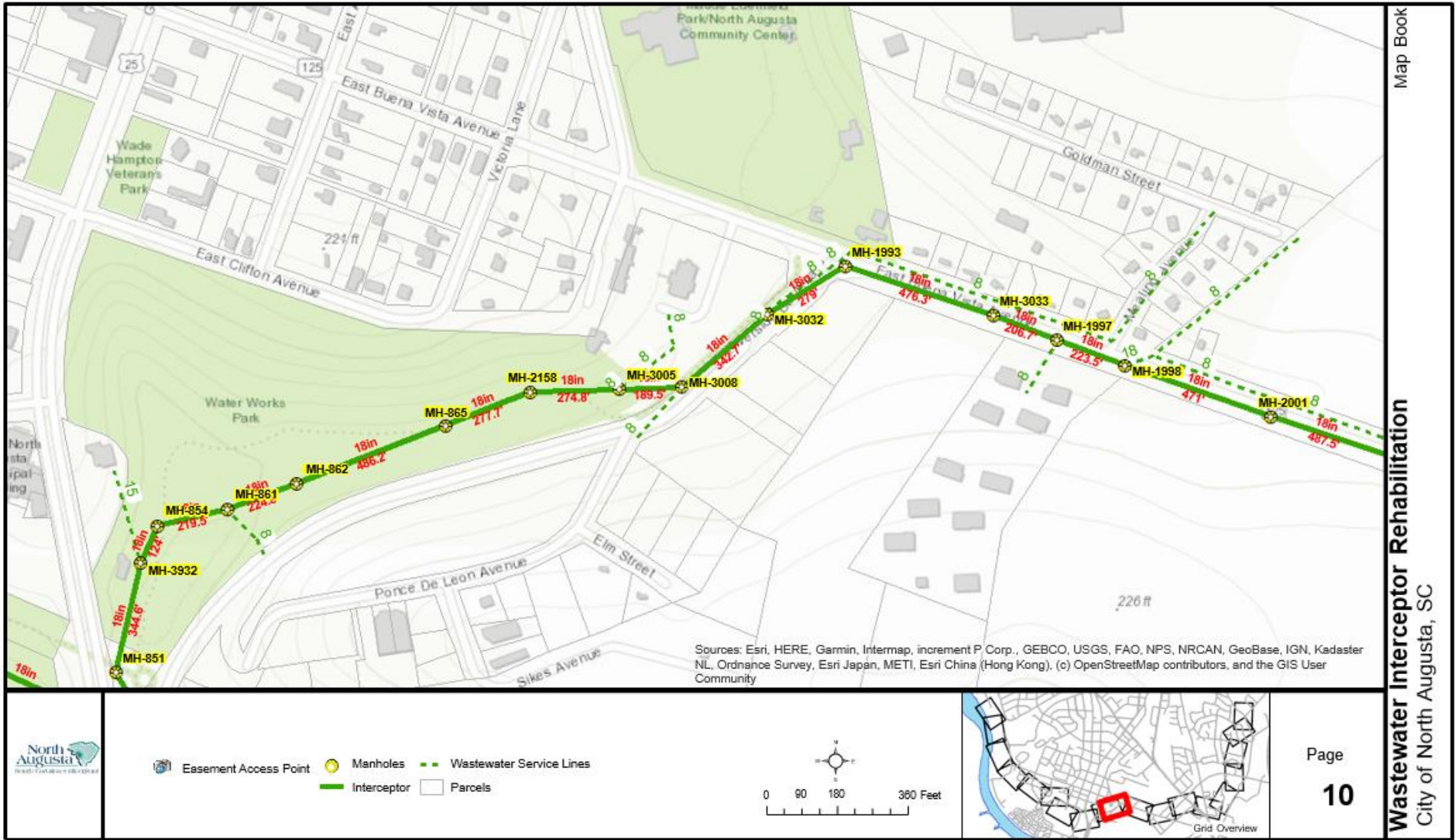



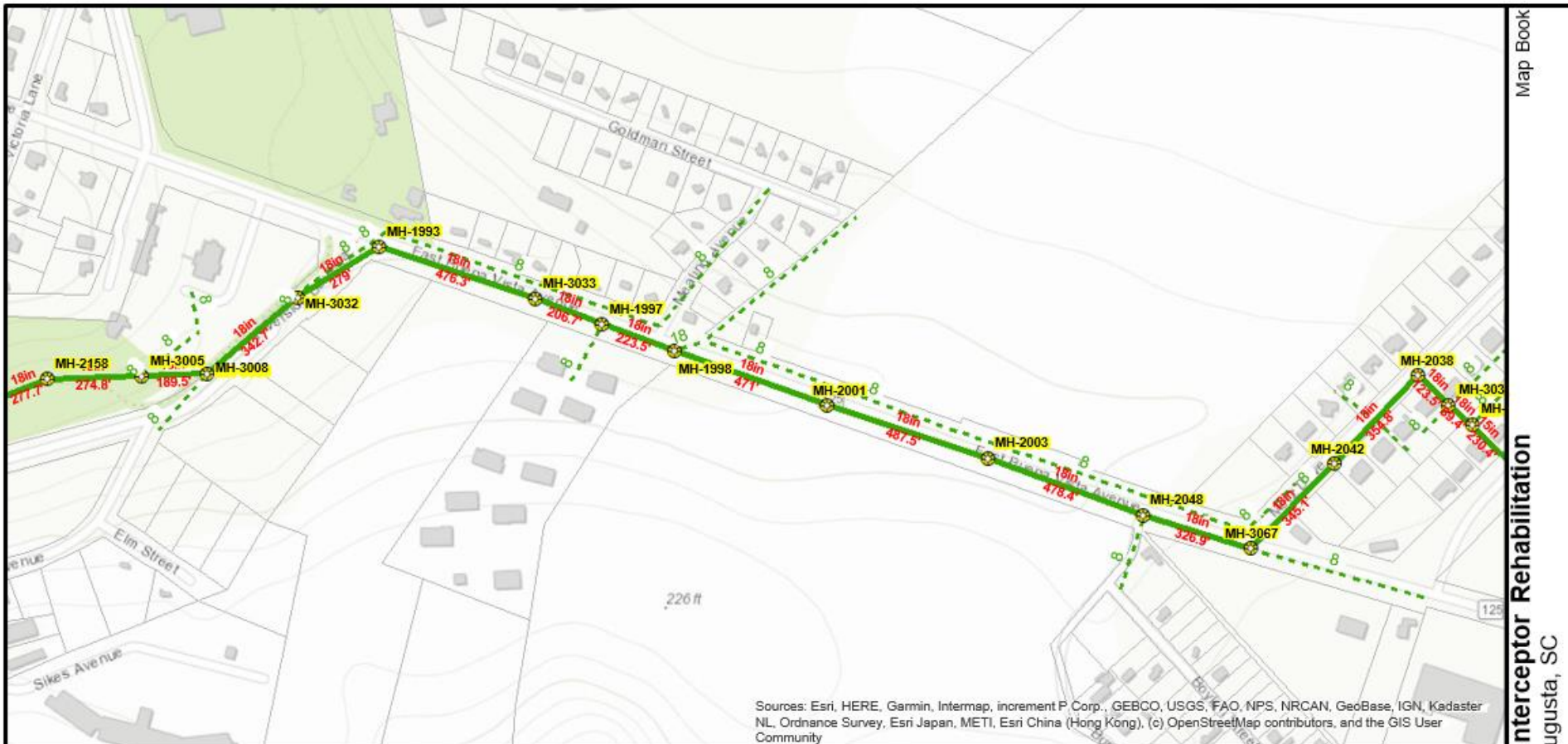

Sources: Esri, HERE, Garmin, Intermap, increment P Corp., GEBCO, USGS, FAO, NPS, NRCAN, GeoBase, IGN, Kadaster NL, Ordnance Survey, Esri Japan, METI, Esri China (Hong Kong), (c) OpenStreetMap contributors, and the GIS User Community



- Easement Access Point
- Manholes
- Wastewater Service Lines
- Interceptor
- Parcels

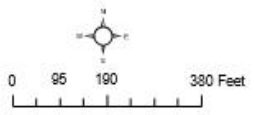



Sources: Esri, HERE, Garmin, Intermap, increment P Corp., GEBCO, USGS, FAO, NPS, NRCAN, GeoBase, IGN, Kadaster NL, Ordnance Survey, Esri Japan, METI, Esri China (Hong Kong), (c) OpenStreetMap contributors, and the GIS User Community



- Easement Access Point
- Manholes
- Wastewater Service Lines
- Interceptor
- Parcels

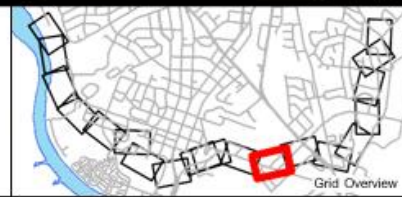
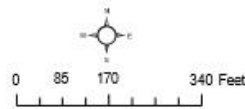

Page  
**13**



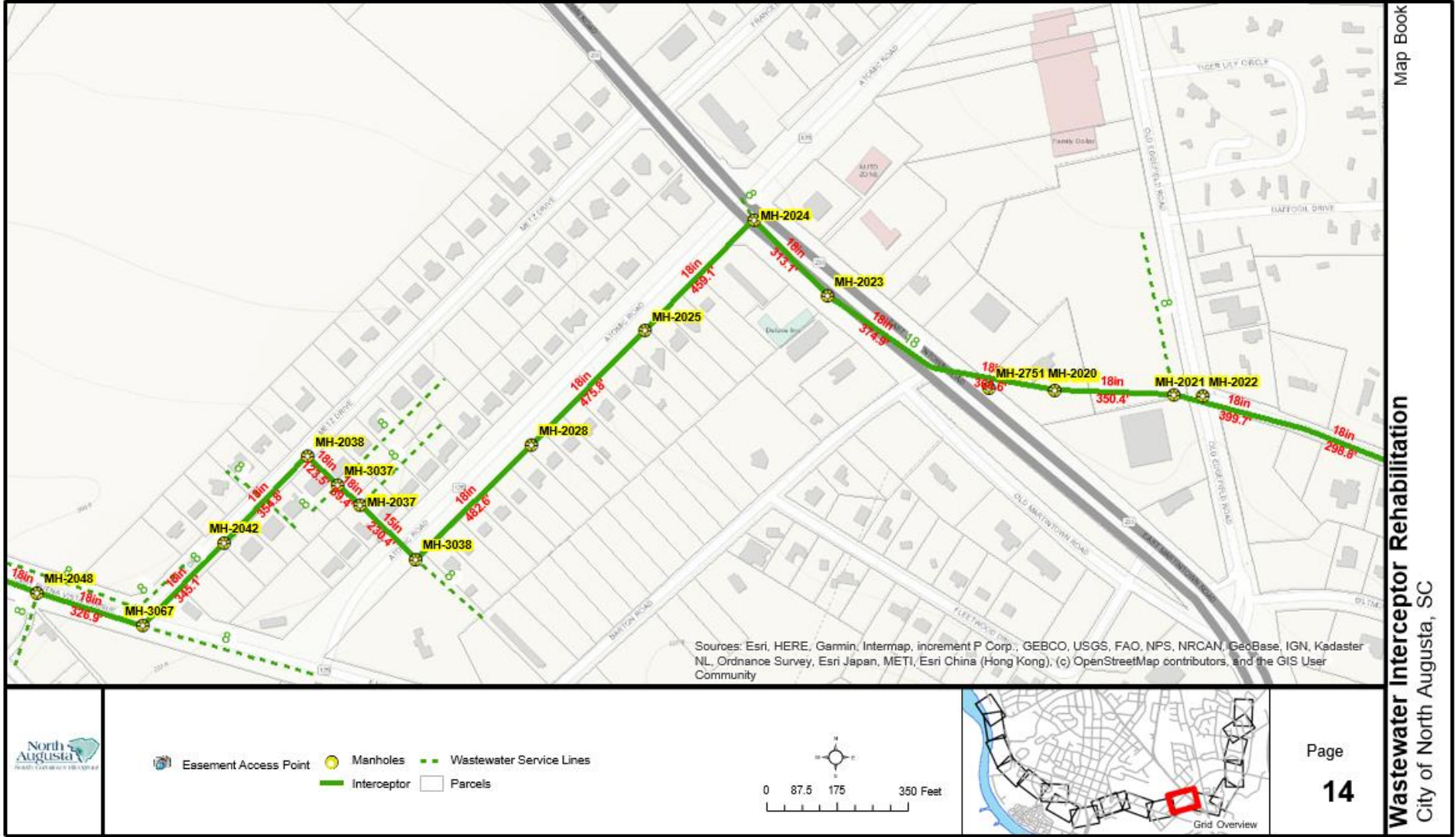

Easement Access Point  
  Manholes  
  Wastewater Service Lines  
 Interceptor  
  Parcels

0 87.5 175 350 Feet

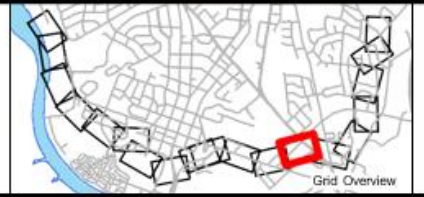

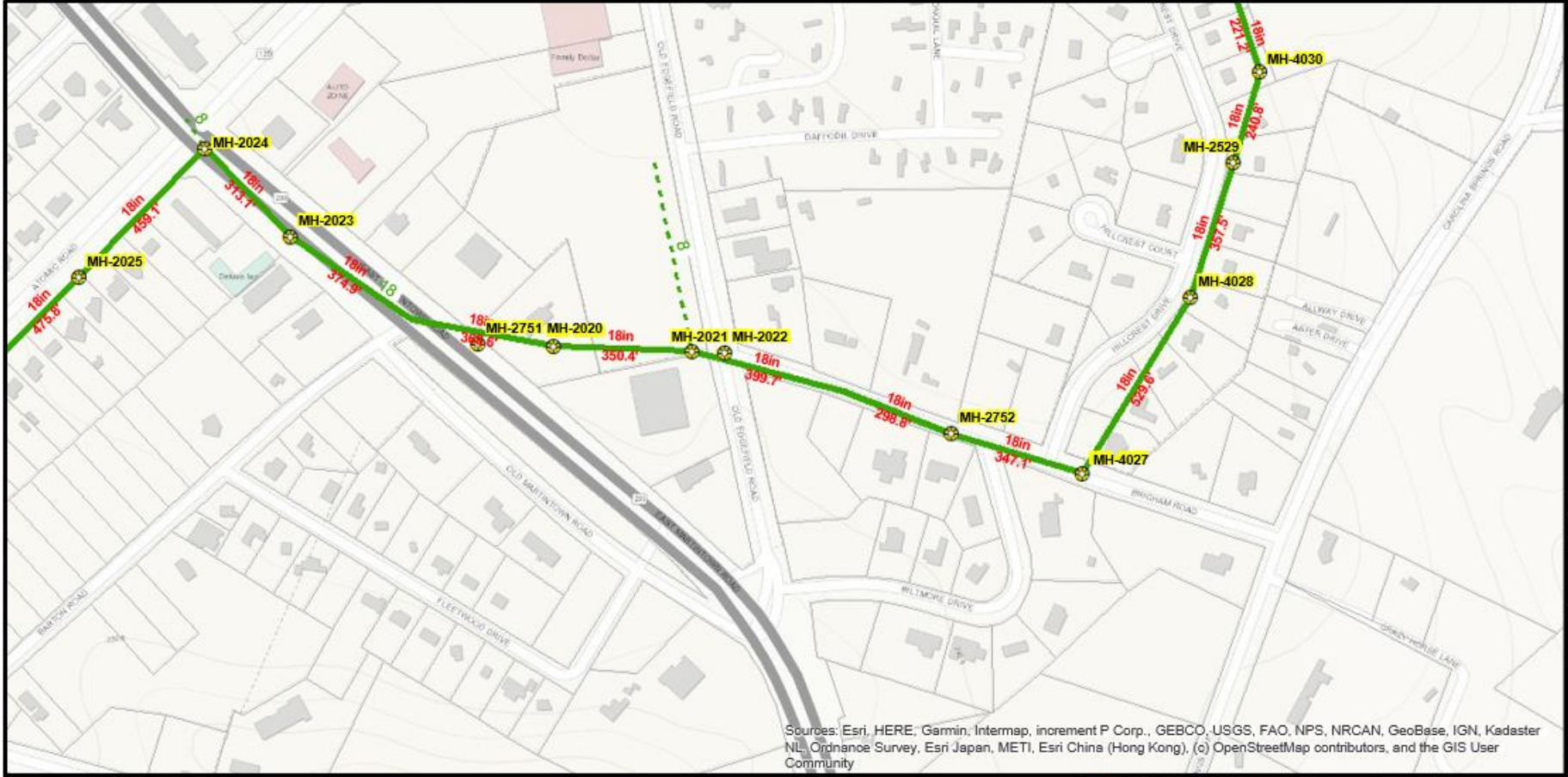

Sources: Esri, HERE, Garmin, Intermap, increment P Corp., GEBCO, USGS, FAO, NPS, NRCAN, GeoBase, IGN, Kadaster NL, Ordnance Survey, Esri Japan, METI, Esri China (Hong Kong), (c) OpenStreetMap contributors, and the GIS User Community



- Easement Access Point
- Manholes
- Wastewater Service Lines
- Interceptor
- Parcels

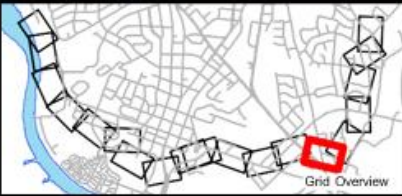
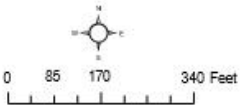



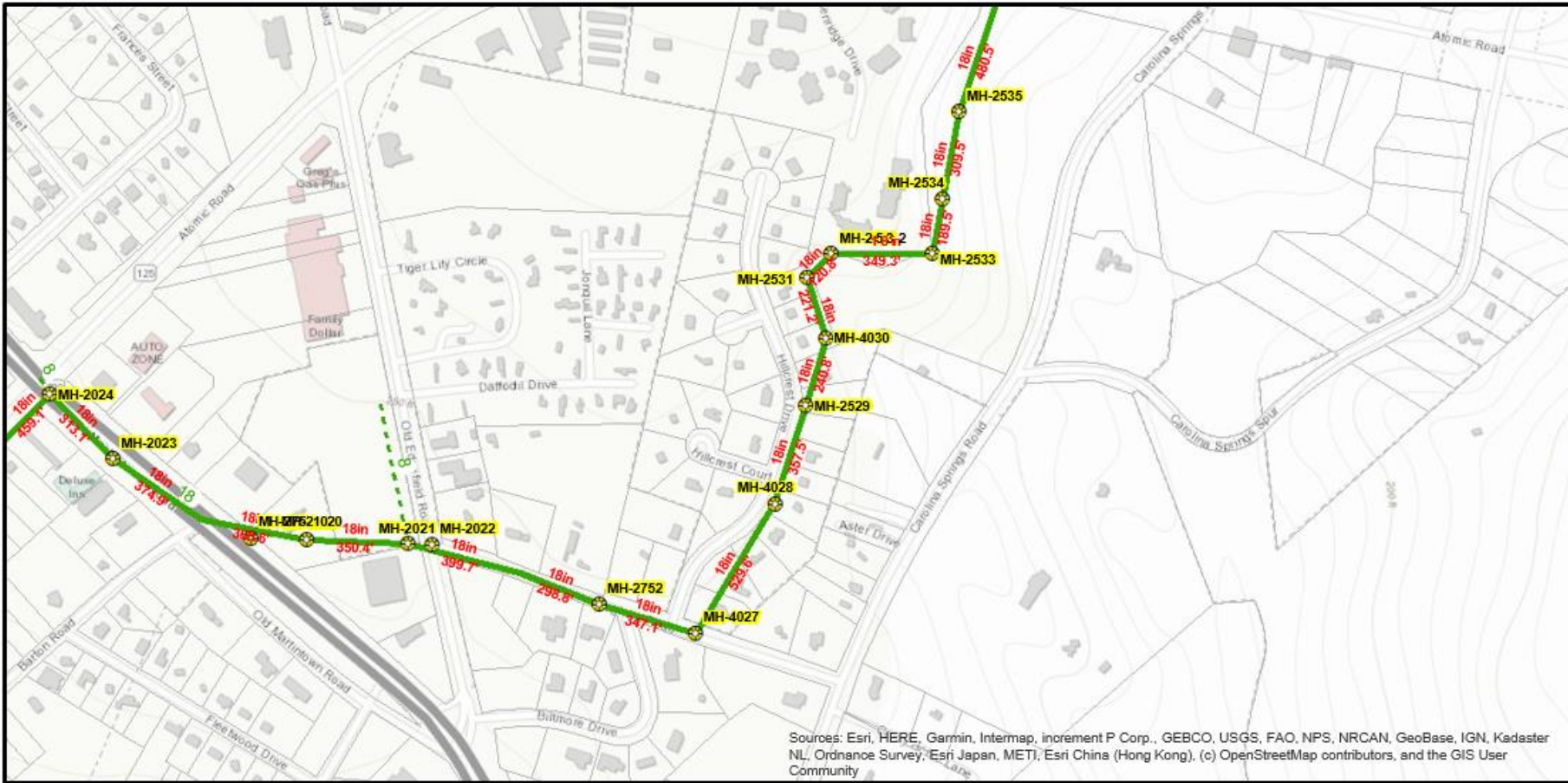

Legend:

- Easement Access Point
- Manholes
- Wastewater Service Lines
- Interceptor
- Parcels

Scale: 0 115 230 460 Feet

North Arrow

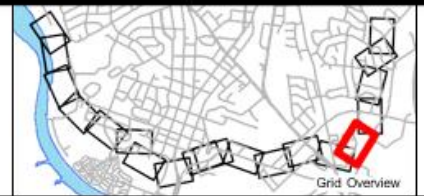



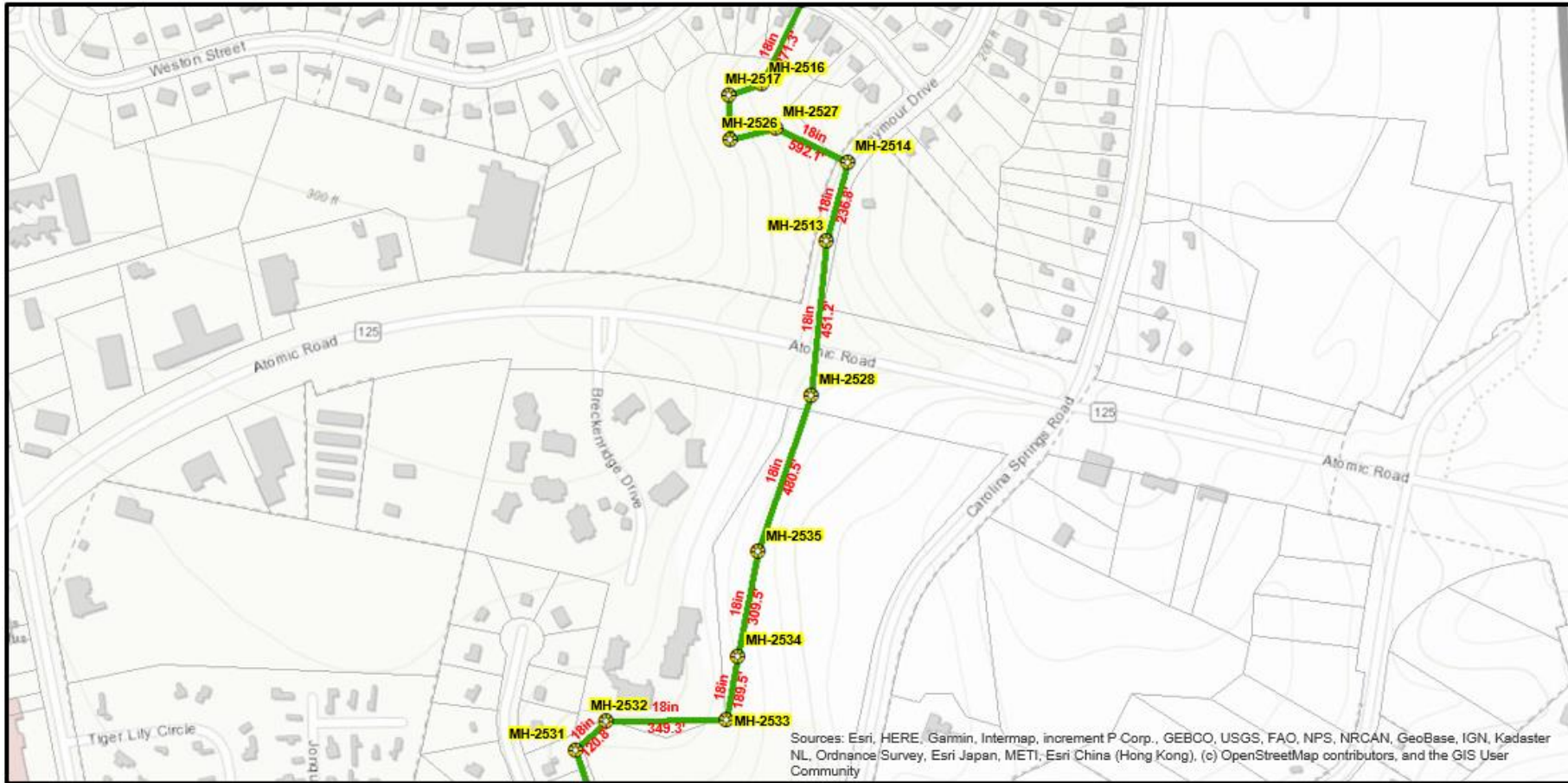

Page  
**16**



Sources: Esri, HERE, Garmin, Intermap, increment P Corp., GEBCO, USGS, FAO, NPS, NRCAN, GeoBase, IGN, Kadaster NL, Ordnance Survey, Esri Japan, METI, Esri China (Hong Kong), (c) OpenStreetMap contributors, and the GIS User Community



-  Easement Access Point
-  Manholes
-  Wastewater Service Lines
-  Interceptor
-  Parcels

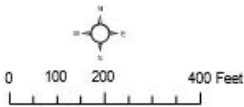

Page  
**17**





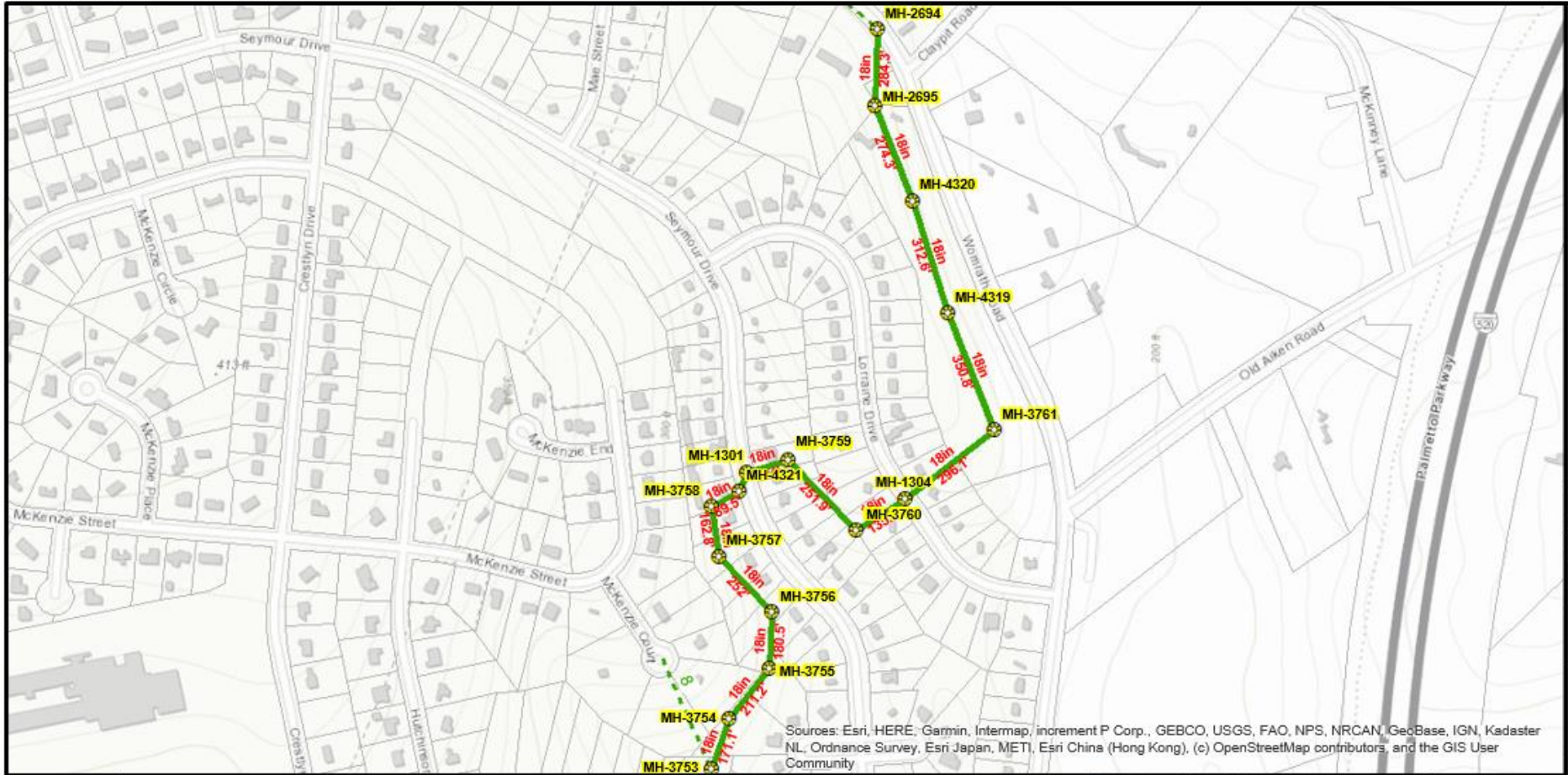

Sources: Esri, HERE, Garmin, Intermap, increment P Corp., GEBCO, USGS, FAO, NPS, NRCAN, GeoBase, IGN, Kadaster NL, Ordnance Survey, Esri Japan, METI, Esri China (Hong Kong), (c) OpenStreetMap contributors, and the GIS User Community



-  Easement Access Point
-  Manholes
-  Wastewater Service Lines
-  Interceptor
-  Parcels

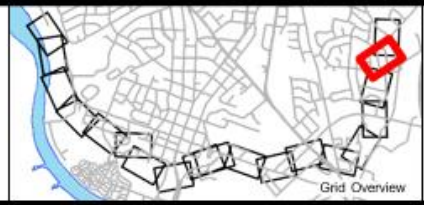
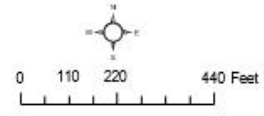

Page  
**19**