

PIPE SUPPORT PIER FOR DRY LAND CROSSING

NOTES:

- MINIMUM SOIL BEARING CAPACITY REQUIRED = 3,000 PSF. ENGINEER SHALL INSPECT ALL FOOTINGS PRIOR TO PLACEMENT OF CONCRETE.
- REINFORCING STEEL - ASTM A615, GRADE 60
- PIPE FOR AERIAL CROSSINGS SHALL BE DUCTILE IRON WITH MECHANICAL JOINTS.
- FOR STEM HEIGHTS OR PIPE DIAMETERS GREATER THAN LISTED IN ABOVE TABLE, PIER DESIGN TO BE FURNISHED BY LICENSED PROFESSIONAL ENGINEER.

PIPE DIAMETER	STEM DIAMETER	STEM HEIGHT	STEM REINFORCING BARS		STEM CONC. VOL. (CU. YARDS)	STEM STEEL WT. (KIB. FT.)	FOOTING CONC. VOL. (CU. YARDS)
			#	SIZE			
8"	2"	1'-3"	1	1/2"	0.18	0.88	1.22
10"	2"	4'-6"	1	1/2"	0.26	1.17	1.79
12"	3"	1'-3"	1	1/2"	0.26	1.17	1.79
12"	3"	4'-6"	1	1/2"	0.36	1.61	2.52
14"	3"	1'-3"	1	1/2"	0.36	1.61	2.52
14"	3"	4'-6"	1	1/2"	0.46	2.05	3.28
16"	3"	1'-3"	1	1/2"	0.46	2.05	3.28
16"	3"	4'-6"	1	1/2"	0.56	2.49	3.94
18"	3"	1'-3"	1	1/2"	0.56	2.49	3.94
18"	3"	4'-6"	1	1/2"	0.66	2.93	4.60
20"	3"	1'-3"	1	1/2"	0.66	2.93	4.60
20"	3"	4'-6"	1	1/2"	0.76	3.37	5.26
24"	3"	1'-3"	1	1/2"	0.76	3.37	5.26
24"	3"	4'-6"	1	1/2"	0.86	3.81	5.92

ISOMETRIC

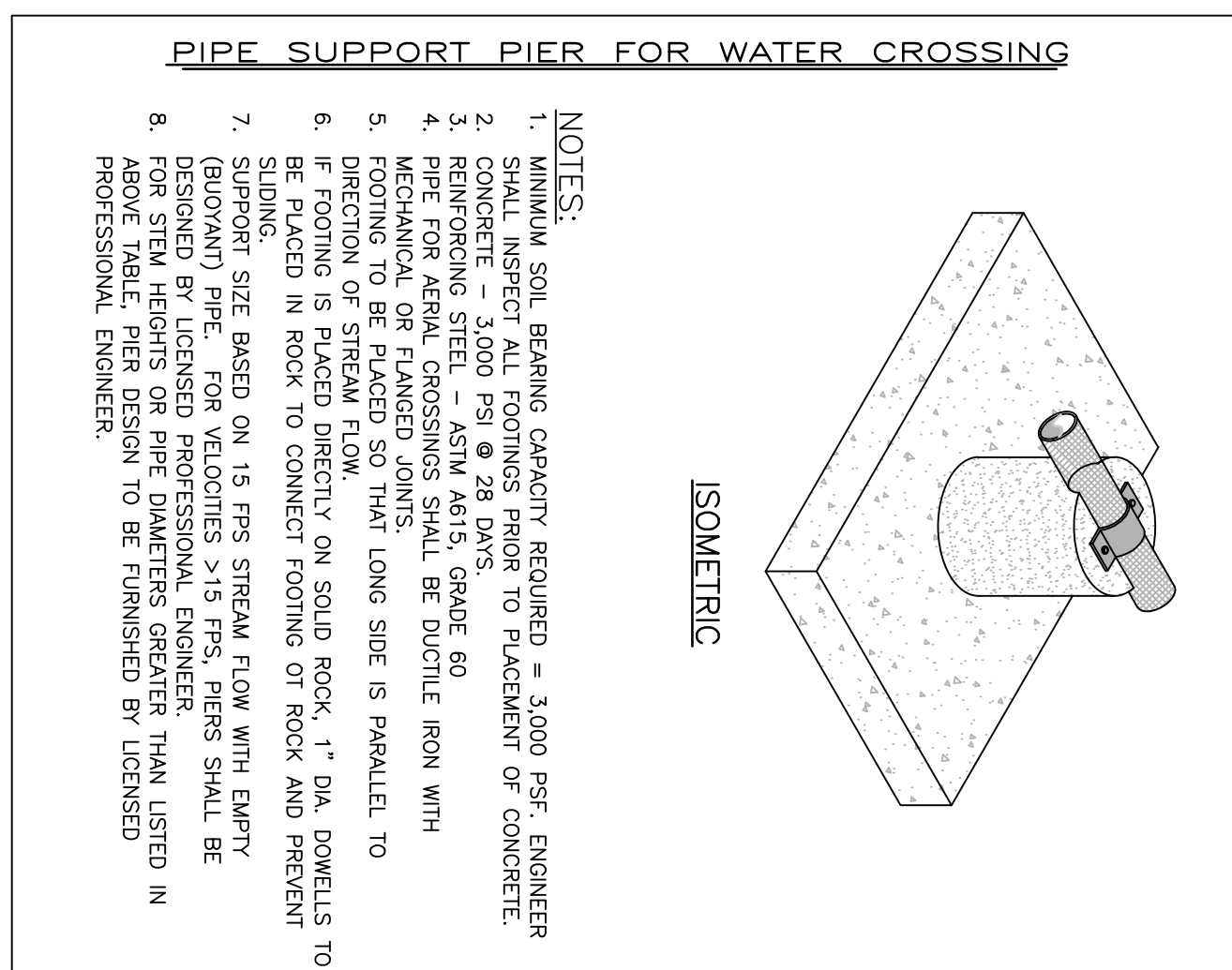
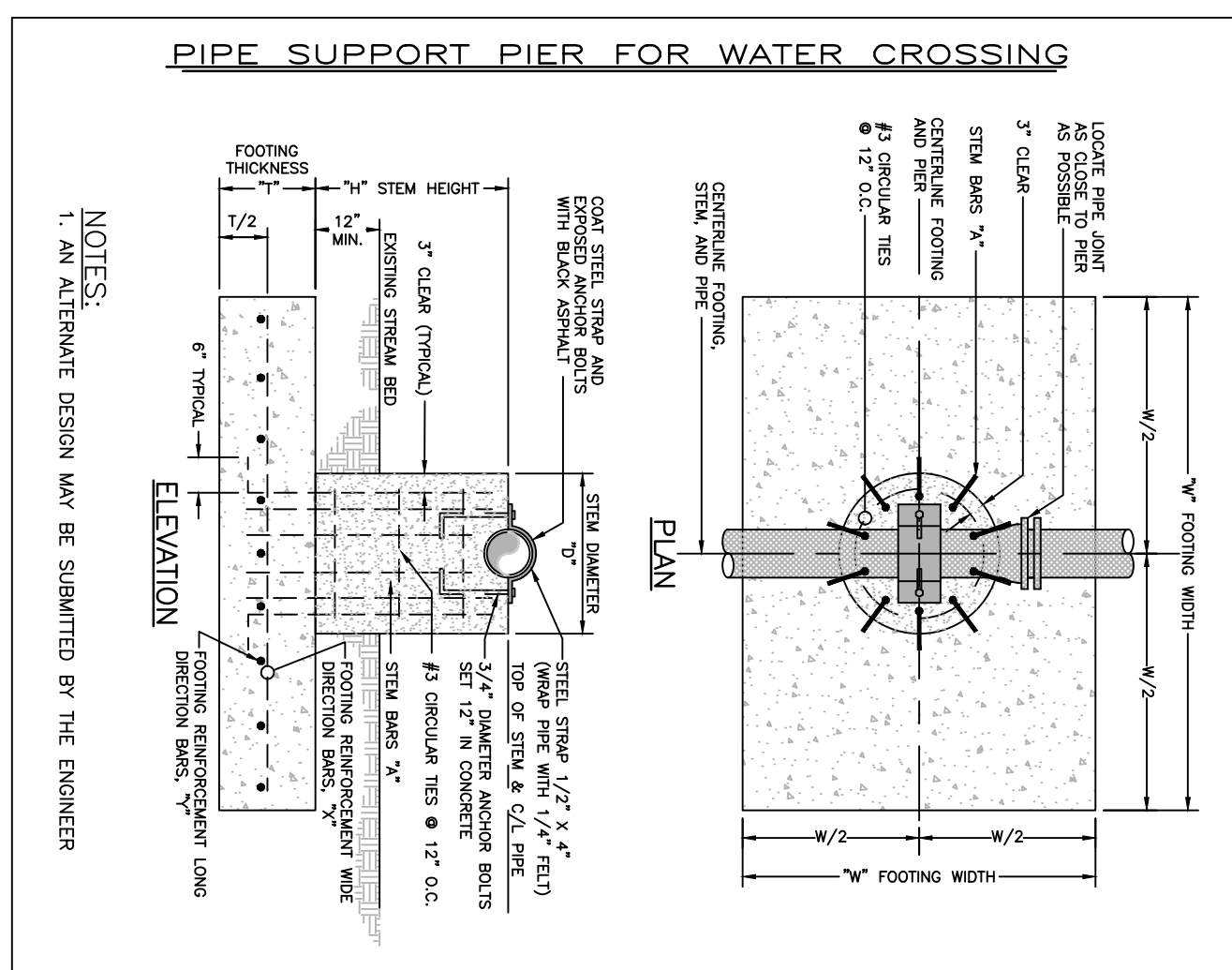

PIPE SUPPORT PIER FOR WATER CROSSING

PIPE DIAMETER	STEM DIAMETER	STEM HEIGHT	STEM REINFORCING BARS		STEM CONC. VOL. (CU. YARDS)	STEM STEEL WT. (KIB. FT.)	FOOTING CONC. VOL. (CU. YARDS)
			#	SIZE			
8"	2"	1'-3"	1	1/2"	0.18	0.88	1.22
10"	2"	4'-6"	1	1/2"	0.26	1.17	1.79
12"	3"	1'-3"	1	1/2"	0.26	1.17	1.79
12"	3"	4'-6"	1	1/2"	0.36	1.61	2.52
14"	3"	1'-3"	1	1/2"	0.36	1.61	2.52
14"	3"	4'-6"	1	1/2"	0.46	2.05	3.28
16"	3"	1'-3"	1	1/2"	0.46	2.05	3.28
16"	3"	4'-6"	1	1/2"	0.56	2.49	3.94
18"	3"	1'-3"	1	1/2"	0.56	2.49	3.94
18"	3"	4'-6"	1	1/2"	0.66	2.93	4.60
20"	3"	1'-3"	1	1/2"	0.66	2.93	4.60
20"	3"	4'-6"	1	1/2"	0.76	3.37	5.26
24"	3"	1'-3"	1	1/2"	0.76	3.37	5.26
24"	3"	4'-6"	1	1/2"	0.86	3.81	5.92

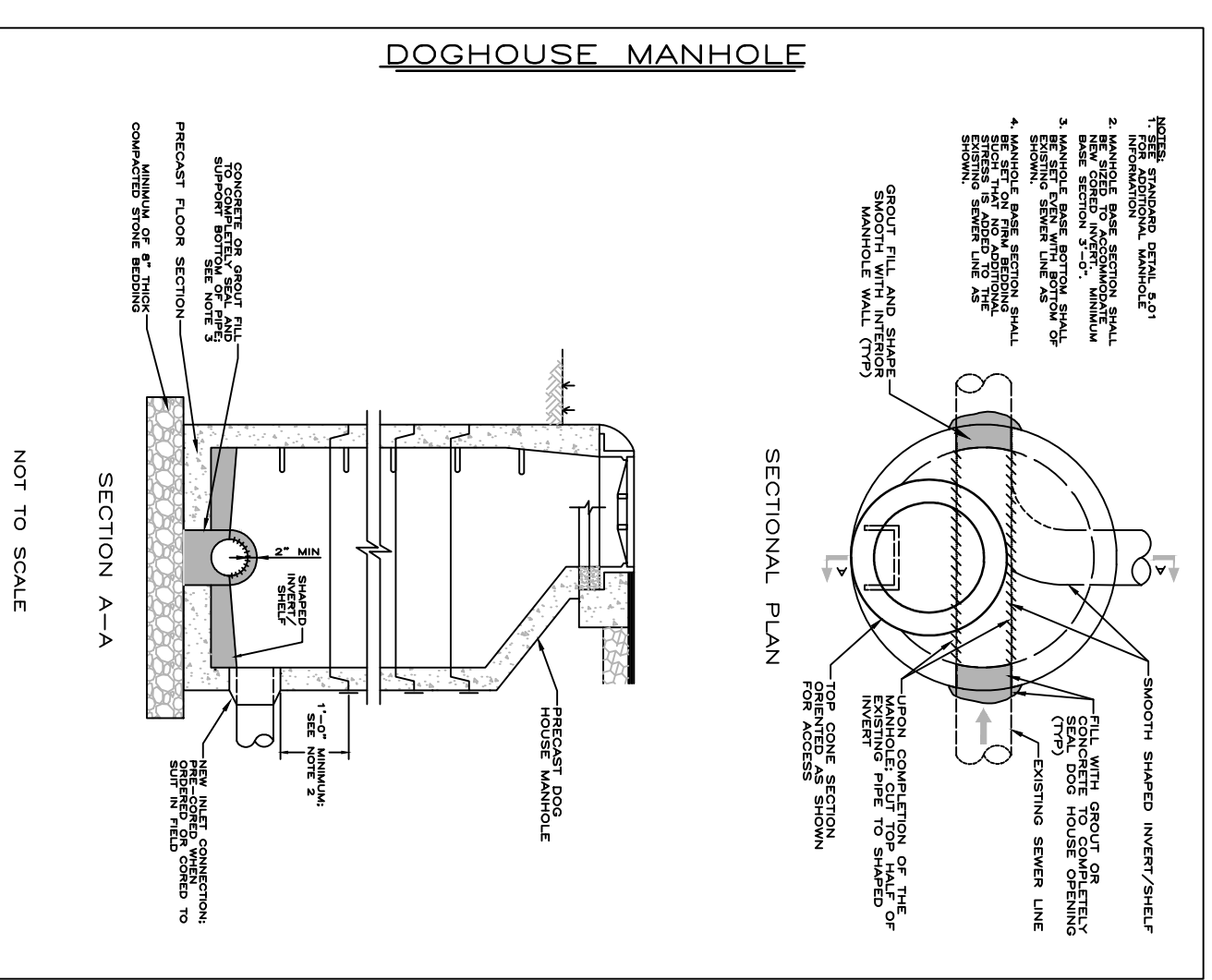
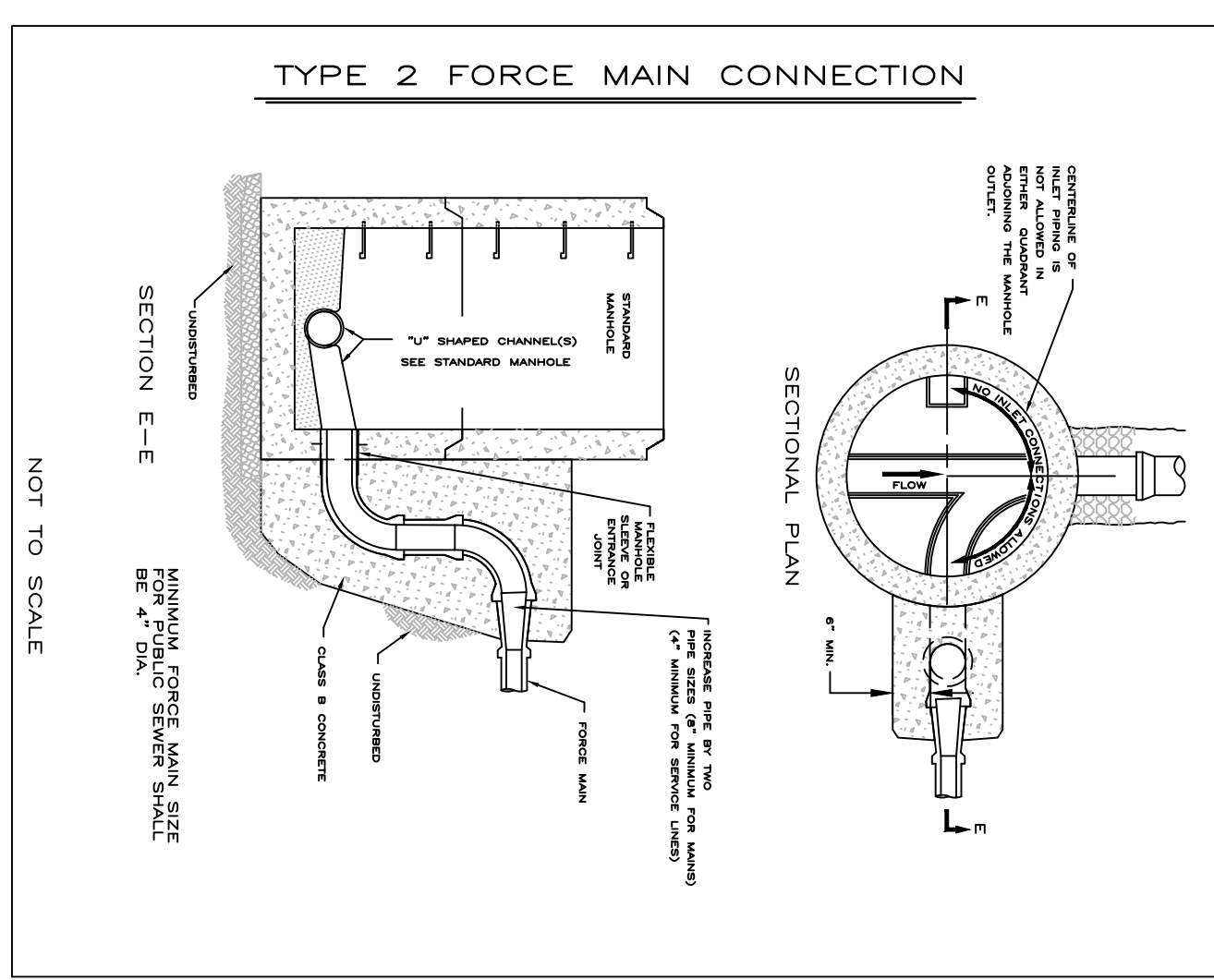
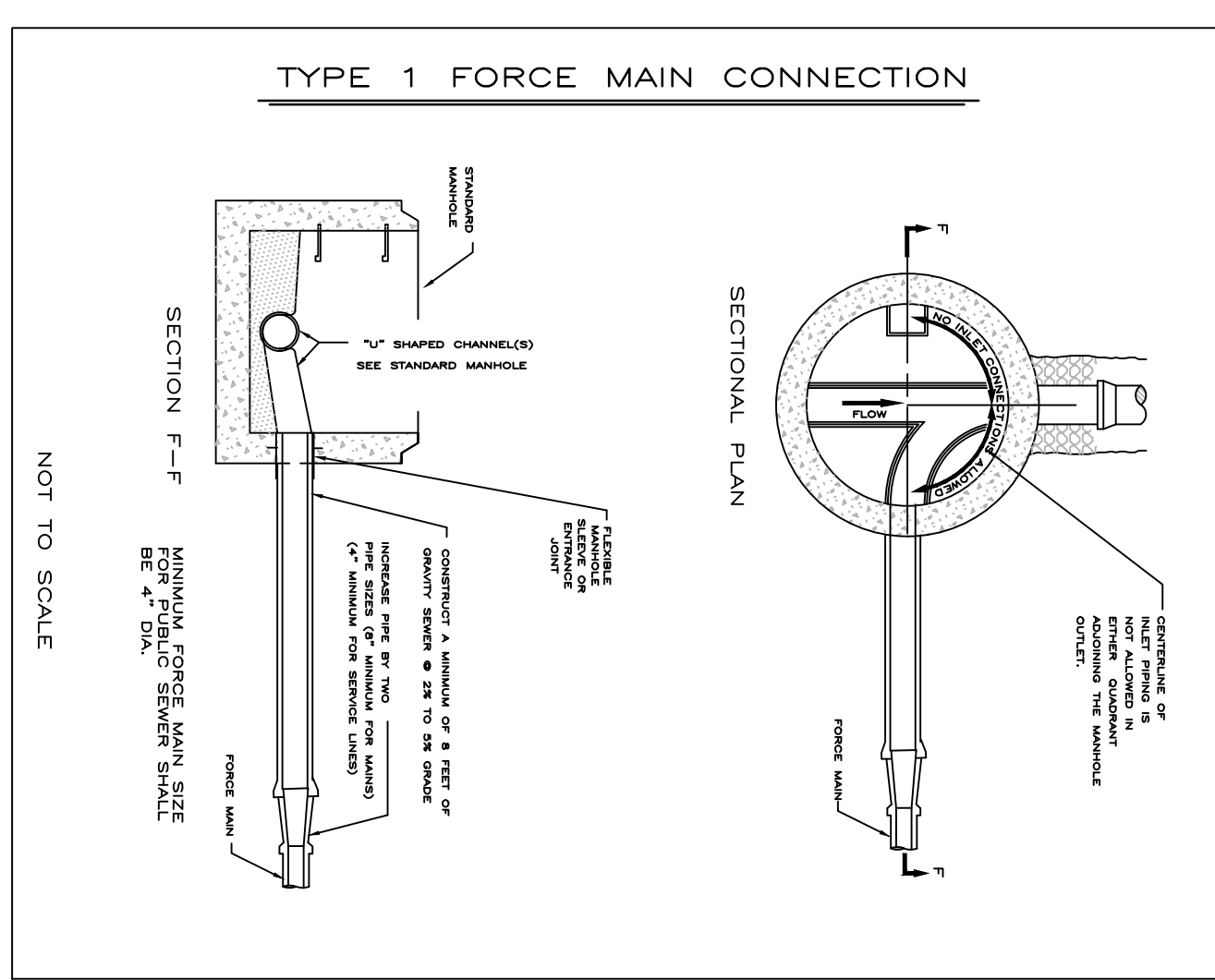
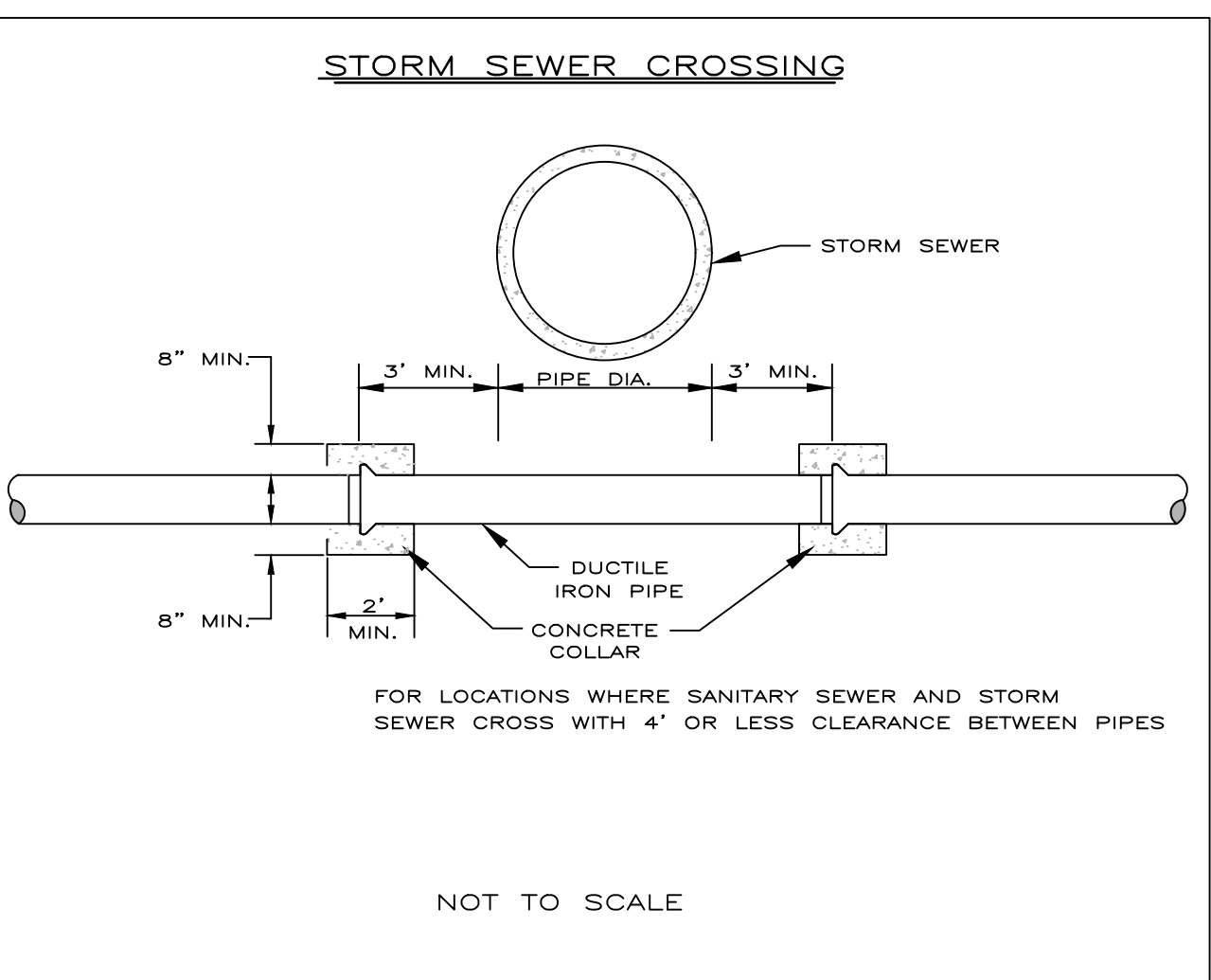

North Augusta
South Carolina
Riverfront

REVISIONS

DATE	BY	DESCRIPTION

SECTION 5 - SANITARY SEWER DETAILS

Prepared By:
City of North Augusta
Engineering Department
100 Georgia Avenue
2nd Floor
North Augusta, South Carolina 29841